



Pure mathematics is, in its way, the poetry of logical ideas.

Shakuntala Devi

Shakuntala Devi popularly known as the "Human Computer" due to her arithmetic abilities.



The beauty of mathematics only shows itself to more patient followers

Maryam Mirzakhani

Maryam Mirzakhani was an Iranian mathematician and a professor of mathematics at Stanford University.

MATHEMATICS

MATHEMATICS

CLASS 8



CLASS VIII



State Council of Educational Research and Training
Telangana, Hyderabad



Published by
The Government of Telangana
Government's Gift for Students' Progress



B8P4A2

MATHEMATICS

Class VIII



Published by

The Government of Telangana, Hyderabad

Respect the Law
Get the Rights

Grow by Education
Behave Humbly



© Government of Telangana, Hyderabad.

First Published 2013

New Impressions 2014, 2015, 2016, 2017, 2018, 2019, 2020, 2021, 2022, 2023

All rights reserved.

No part of this publication may be reproduced, stored in a retrieval system, or transmitted, in any form or by any means without the prior permission in writing of the publisher, nor be otherwise circulated in any form of binding or cover other than that in which it is published and without a similar condition including this condition being imposed on the subsequent purchaser.

The copy right holder of this book is the Director of School Education, Hyderabad, Telangana

This Book has been printed on 90 G.S.M. Maplitho
Title Page 250 G.S.M. White Art Card

Government's Gift for Students' Progress 2023-24

Printed in India
at the Telangana Govt. Text Book Press,
Mint Compound, Hyderabad,
Telangana.

Foreword

Education is a process of human enlightenment and empowerment. Recognizing the enormous potential of education, all progressive societies have committed to the Universalization of Elementary Education with an explicit aim of providing quality education to all. As the next step, universalization of Secondary Education has gained momentum.

The secondary stage marks the beginning of the transition from functional mathematics studied upto the upper primary stage to the study of mathematics as a discipline. The logical proofs of propositions, theorems etc. are introduced at this stage. Apart from being a specific subject, it is to be treated as a concomitant to every subject involving analysis as reasoning.

I am confident that the children in our state of Telangana learn to enjoy mathematics, make mathematics a part of their life experience, pose and solve meaningful problems, understand the basic structure of mathematics by reading this text book.

For teachers, to understand and absorb critical issues on curricular and pedagogic perspectives duly focusing on learning rather than of marks, is the need of the hour. Also coping with a mixed class room environment is essentially required for effective transaction of curriculum in teaching learning process. Nurturing class room culture to inculcate positive interest among children with difference in opinions and presumptions of life style, to infuse life in to knowledge is a thrust in the teaching job.

The afore said vision of mathematics teaching presented in State Curriculum Frame work (SCF -2011) has been elaborated in its mathematics position paper which also clearly lays down the academic standards of mathematics teaching in the state. The text books make an attempt to concretize all the sentiments. In the endeavor to continuously improve the quality of our work, we welcome comments and suggestions in this regard.

The State Council for Education Research and Training, Telangana appreciates the hard work of the text book development committee and several teachers from all over the state who have contributed to the development of this text book at different levels. I am thankful to the District Educational Officers, Mandal Educational Officers and Head teachers for making this mission possible. I also thank the institutions and organizations which have given their time in the development of this text book. I am grateful to the office of the Commissioner & Director of School Education, (T.S.) and Vidya Bhawan Society, Udaipur, Rajasthan for extending cooperation in developing this text book. Our special thanks to Faculty of School of Education Tata Institute of Social Sciences (TISS), Hyderabad and Sri Ramesh Khade, Communication Officer, CETE, TISS-Mumbai and Designers identified by SCERT for their technical support in redesigning of the textbooks.

Place : Hyderabad
Date : 07 December 2022

Director
SCERT, Hyderabad

NATIONAL ANTHEM

Jana-gana-mana-adhinayaka, jaya he
Bharata-bhagya-vidhata.
Punjab-Sindh-Gujarat-Maratha
Dravida-Utkala-Banga
Vindhya-Himachala-Yamuna-Ganga
Uchchhala-jaladhi-taranga.
Tava shubha name jage,
Tava shubha asisa mage,
Gahe tava jaya gatha,
Jana-gana-mangala-dayaka jaya he
Bharata-bhagya-vidhata.
Jaya he! jaya he! jaya he!
Jaya jaya jaya, jaya he!!

- Rabindranath Tagore

PLEDGE

“India is my country; all Indians are my brothers and sisters.
I love my country, and I am proud of its rich and varied heritage.

I shall always strive to be worthy of it.

I shall give my parents, teachers and all elders respect,
and treat everyone with courtesy. I shall be kind to animals.

To my country and my people, I pledge my devotion.

In their well-being and prosperity alone, lies my happiness.”

- Pydimarri Venkata Subba Rao

INDEX

Sl. No.	Name of the Chapter	Month	Page No.
1	Rational Numbers	June	1-36
2	Linear Equations in One Variable	June, July	37-61
3	Construction of Quadrilaterals	July	62-83
4	Exponents and Powers	July	84-98
5	Comparing Quantities using Proportion	August	99-124
6	Square Roots and Cube Roots	August	125-150
7	Frequency Distribution Tables and Graphs	September	151-183
8	Exploring Geometrical Figures	September	184-201
9	Area of Plane Figures	October	202-233
10	Direct and Inverse Proportions	November	234-250
11	Algebraic Expressions	November	251-269
12	Factorisation	December	270-284
13	Visualising 3-D in 2-D	January	285-299
14	Surface Areas And Volume (Cube and Cuboid)	January, February	300-313
15	Playing with Numbers	February	314-339
	Revision	March	



THE CONSTITUTION OF INDIA

Preamble

WE, THE PEOPLE OF INDIA, having solemnly resolved to constitute India into a **SOVEREIGN SOCIALIST SECULAR DEMOCRATIC REPUBLIC** and to secure to all its citizens:

JUSTICE, social, economic and political;

LIBERTY of thought, expression, belief, faith and worship;

EQUALITY of status and of opportunity; and to promote among them all

FRATERNITY assuring the dignity of the individual and the unity and integrity of the Nation;

IN OUR CONSTITUENT ASSEMBLY this twenty-sixth day of November, 1949 do **HEREBY ADOPT, ENACT AND GIVE TO OURSELVES THIS CONSTITUTION.**



R6J8J3

1.0 Introduction

Salma wants to buy 3 pens at 5 rupees each. Her friend Satheesh wants to buy 2 similar pens. So they go to a wholesale shop. The shopkeeper says that a packet of five pens costs ₹ 22. How much does each pen cost?

We can easily calculate the cost of each pen to be ₹ $\frac{22}{5}$.

Is there any natural number to represent this cost? Is there any whole number or integer to represent this? This number can not be represented by a whole number. We need a fractional number to represent this quantity.

Consider one more example.

Observe the following various readings of temperature recorded on a particular day in Simla.

Timings	10.00 a.m.	12.00 Noon	3.00 p.m.	7.00 p.m.	10.00 p.m.
Temperature	11 °C	14 °C	17 °C	10 °C	5 °C

In each case what is the change in temperature per hour?

Case I Morning hours : change in temperature per hour = $\frac{14^{\circ}\text{C} - 11^{\circ}\text{C}}{2} = \frac{3^{\circ}}{2}$ C/hrs.
(10.00 A.M. - 12.00 Noon)

Case II Afternoon hours: change in temperature per hour = $\frac{17^{\circ}\text{C} - 14^{\circ}\text{C}}{3} = 1^{\circ}\text{C/hrs.}$
(12.00 Noon - 3.00 P.M.)

Case III Evening hours : change in temperature per hour = $\frac{10^{\circ}\text{C} - 17^{\circ}\text{C}}{4} = \frac{-7^{\circ}}{4}$ C/hrs.
(3.00 P.M. - 7.00 P.M.)

Case IV Night hours : change in temperature per hour = $\frac{5^{\circ}\text{C} - 10^{\circ}\text{C}}{3} = \frac{-5^{\circ}}{3}$ C/hrs.
(7.00 P.M. - 10.00 P.M.)

In the above cases we come across numbers like $\frac{3}{2}$ °C, 1 °C, $\frac{-7}{4}$ °C, $\frac{-5}{3}$ °C.

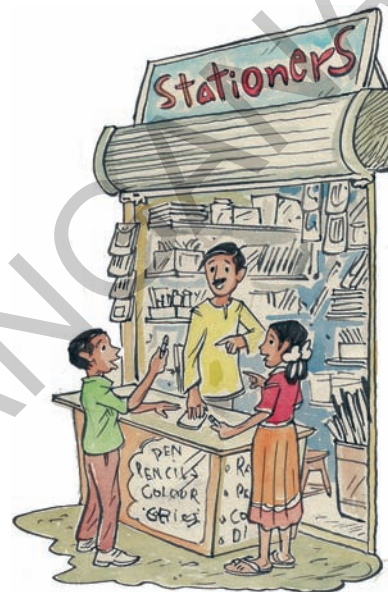

The numbers used in these temperature are $\frac{3}{2}$, 1 , $\frac{-7}{4}$, $\frac{-5}{3}$. What can be call these numbers? These numbers include both positive and negative fractional numbers and can be written as $\frac{p}{q}$, where $q \neq 0$ and p can be positive or negative.

Let us see some more such numbers.

$$\frac{3}{4}, \frac{7}{9}, \frac{-10}{17}, \frac{3}{-2}, \frac{2013}{2014}, \dots$$

The numbers which are expressed in the form of $\frac{p}{q}$, where p and q are integers and $q \neq 0$, are called 'Rational Numbers' and the set of all rational numbers is denoted by 'Q'. These are also called Quotient numbers.

Observe the following

We can express any natural number in $\frac{p}{q}$ form, for ex. 5 as $\frac{5}{1}$ or $\frac{10}{2}$ or $\frac{15}{3}$

Similarly we can also express the whole number 0 as $\frac{0}{1}$ or $\frac{0}{2}$ or $\frac{0}{5}$

We can also express an integer in $\frac{p}{q}$ form, for ex. -3 as $\frac{-3}{1}$ or $\frac{-6}{2}$

That is all the above $\frac{p}{q}$ forms $\frac{15}{3}$, $\frac{0}{5}$ and $\frac{-6}{2}$ are rational numbers. So all integers are also included in rational numbers. From the above observation we can conclude that all natural numbers, all whole numbers and all integers are rational numbers.



Do This

Consider the following collection of numbers $1, \frac{1}{2}, -2, 0.5, 4\frac{1}{2}, \frac{-33}{7}, 0, \frac{4}{7}, 22, -5, \frac{2}{19}, 0.125$. Write these numbers under the appropriate category.

[A number can be written in more than one collection]

- (i) Natural numbers _____
- (ii) Whole numbers _____
- (iii) Integers _____
- (iv) Rational numbers _____

Would you leave out any of the given numbers from rational numbers?

Is every natural number, whole number and integer a rational number ?



Try These

1. Hamid says $\frac{5}{3}$ is a rational number and 5 is only a natural number. Sakshi says both are rational numbers. Who do you agree with?
2. Give an example to satisfy the following statements.
 - (i) All natural numbers are whole numbers but all whole numbers need not be natural numbers.
 - (ii) All whole numbers are integers but all integers are not whole numbers.
 - (iii) All integers are rational numbers but all rational numbers need not be integers.

We have already learnt basic operations on rational numbers in earlier classes. Let us explore some properties of operations on rational numbers.

1.1 Operations on Rational numbers

We have already discussed addition and subtraction of Rational numbers in 7th class. Let us recall them by doing the following problems.

Solve

(i) $\frac{9}{10} + \left(\frac{-13}{8}\right)$

(ii) $1\frac{3}{5} + 4\frac{2}{7}$

(iii) $\frac{-7}{16} - \left(\frac{-9}{20}\right)$

(iv) $\frac{-11}{14} - \left(\frac{1}{21}\right)$

(v) Find the additive inverse of the following numbers: $\frac{-7}{6}$, $\frac{1}{10}$, $\frac{-3}{4}$, 8

1.1.1 Multiplication of Rational Numbers

Now, we learn how to multiply the rational numbers. In class 7 we have learnt how to multiply fractional numbers. We follow a similar process for multiplication of rational numbers also.

Consider the rational numbers $\frac{2}{3}$ and $\frac{5}{7}$. These are also fractional numbers.

We multiply $\frac{2}{3}$ and $\frac{5}{7}$

$$\frac{2}{3} \times \frac{5}{7} = \frac{2 \times 5}{3 \times 7} = \frac{10}{21} \quad \left(\frac{\text{Product of numerator}}{\text{Product of denominator}} \right)$$

Now multiply $\frac{-2}{3} \times \frac{5}{7}$

We get $\frac{-2 \times 5}{3 \times 7} = \frac{-10}{21}$

Let us do one more example $\frac{-10}{21} \times \frac{14}{25}$

$$\frac{-10}{21} \times \frac{14}{25} = \frac{-10 \times 14}{21 \times 25} = \frac{\overset{28}{\cancel{-140}}}{\underset{105}{\cancel{525}}} = \frac{-28}{105} = \frac{-4}{15}$$

Or we can do like this also.

$$\frac{\overset{2/}{\cancel{-10}}}{\underset{3/}{\cancel{21}}} \times \frac{\overset{2/}{\cancel{14}}}{\underset{5/}{\cancel{25}}} = \frac{-4}{15}$$

 Do this

(i) $\frac{18}{11} \times \frac{-33}{45}$

(ii) $\frac{-7}{17} \times \frac{-1}{10}$

(iii) $\frac{-105}{72} \times \frac{18}{15}$

(iv) $\frac{13}{120} \times \frac{100}{16}$

1.1.2 Division of Rational Numbers

Let us observe the following.

$$\frac{2}{5} \times \frac{5}{2} = 1$$

$$\frac{-9}{11} \times \frac{11}{-9} = 1$$

Here we notice that the product is '1'. If the product of any two rational numbers is '1' are called the multiplicative inverse of each other.

Here $\frac{2}{5}$ and $\frac{5}{2}$; $\frac{-9}{11}$ and $\frac{11}{-9}$ are multiplicative inverse of each other.

Write multiplicative inverse of $\frac{-3}{7}$, 11 , $\frac{9}{5}$, $\frac{1}{-17}$.

In class 7 we have learnt to divide fractional numbers. We follow a similar process for division of Rational numbers.

Consider the rational number $\frac{3}{4}$ and $\frac{7}{11}$. These are also fractional numbers.

We divide $\frac{3}{4}$ with $\frac{7}{11}$.

$$\begin{aligned} \frac{3}{4} \div \frac{7}{11} &= \frac{3}{4} \times \frac{11}{7} && \text{(Multiplicative inverse of } \frac{7}{11} \text{)} \\ &= \frac{3 \times 11}{4 \times 7} = \frac{33}{28} = 1\frac{5}{28} \end{aligned}$$

Let's do the following examples :

$$\begin{aligned} \text{(i)} \quad \frac{-5}{9} \div \frac{3}{4} &= \frac{-5}{9} \times \frac{4}{3} && \text{(Multiplicative inverse of } \frac{3}{4} \text{)} \\ &= \frac{-5 \times 4}{9 \times 3} = \frac{-20}{27} \end{aligned}$$

$$\text{(ii)} \quad \frac{-12}{21} \div \left(\frac{2}{-7}\right) = \frac{\cancel{-12}^{\cancel{2}}}{\cancel{21}_3} \times \left(\frac{\cancel{-7}}{\cancel{2}}\right) = \frac{\cancel{6}}{\cancel{3}} = 2 \quad \text{(Multiplicative inverse of } \frac{2}{-7} \text{)}$$



Do this

$$\text{(i)} \quad \frac{8}{5} \div \frac{2}{3}$$

$$\text{(ii)} \quad \frac{18}{25} \div \left(\frac{-72}{75}\right)$$

$$\text{(iii)} \quad \frac{-125}{64} \div \frac{50}{16}$$

$$\text{(iv)} \quad \text{Divide } \frac{-512}{441} \text{ with } \frac{-1024}{21}$$

1.2 Properties of Rational numbers

1.2.1 Closure property

What is closure property?

If the sum of two whole numbers is also a whole number, then, we say that the set of whole numbers satisfy closure property under addition.

(i) Whole numbers and Integers

Let us recall the operations under which the whole numbers and integers are closed. Complete the following table with necessary arguments and relevant examples.

Numbers	Operations			
	Addition	Subtraction	Multiplications	Division
Whole numbers	Closed since $a + b$ is a whole number for any two whole numbers a and b example - -	Not closed since $5 - 7 = -2$ which is not a whole number	Closed since - - -	Not closed since $5 \div 8 = \frac{5}{8}$ which is not a whole number.
Integers	- - -	Closed Since $a - b$ is an integer for any two integers a and b example.	- - -	Not closed since - - -

(ii) Rational numbers - Closure Property

(a) Addition:

Consider any two rational numbers $\frac{2}{7}, \frac{5}{8}$

$$\frac{2}{7} + \frac{5}{8} = \frac{16 + 35}{56} = \frac{51}{56}$$

The result $\frac{51}{56}$ is again a rational number

$8 + \left(\frac{-19}{2}\right) = \text{_____}$ Is it a rational number?

$\frac{2}{7} + \frac{-2}{7} = \text{_____}$ Do you get a rational number?

Check this for few more in the following pairs.

$3 + \frac{5}{7}, 0 + \frac{1}{2}, \frac{7}{2} + \frac{2}{7}$

We observe that the sum of any two rational numbers is again a rational number. Thus we can say that rational numbers are closed under addition.

Hence $(a + b)$ is a rational number for any two rational numbers a and b , i.e. $\forall a, b \in \mathbb{Q}; (a + b) \in \mathbb{Q}$.

\in belongs to,

Let $A = \{1, 2, 3\}$

The element 3 is in A and it is written as $3 \in A$ and we read it as 3 belongs to A .

\forall for all

\forall is the symbol for all or for every.

If we write $\forall a, b \in \mathbb{Q}$, it means

(b) Subtraction:

Consider two rational numbers $\frac{5}{9}$ and $\frac{3}{4}$

$$\text{Then } \frac{5}{9} - \frac{3}{4} = \frac{(5 \times 4) - (3 \times 9)}{36} = \frac{20 - 27}{36} = \frac{-7}{36}$$

Again we got a rational number $\frac{-7}{36}$ (since $-7, 36$ are integers and 36 is not a zero,

hence $\frac{-7}{36}$ is a rational number).

Check this in the following rational numbers also.

(i) $\frac{2}{3} - \frac{3}{7} = \frac{14-9}{21} = \underline{\hspace{2cm}}$ Is it a rational number ?

(ii) $\left(\frac{48}{9}\right) - \frac{11}{18} = \underline{\hspace{2cm}}$ Is it a rational number?

We find that the difference is also a rational number for any two rational numbers. Thus rational numbers are closed under subtraction. Hence $(a - b)$ is a rational number for any two rational number 'a' and 'b',

$$\text{i.e., } \forall a, b \in \mathbb{Q}, (a-b) \in \mathbb{Q}$$

(c) Multiplication:

Observe the following

$$3 \times \frac{1}{2} = \frac{3}{2}$$

$$\frac{6}{5} \times \frac{-11}{2} = \frac{-66}{10} = \frac{-33}{5}$$

$$\frac{3}{7} \times \frac{5}{2} = \underline{\hspace{2cm}}; \quad \frac{2}{1} \times \frac{19}{13} = \underline{\hspace{2cm}}$$

We can notice that in all the cases the product of two rational numbers is a rational number.

Try for some more pairs of rational numbers and check whether their product is a rational number or not . Can you find any two rational numbers whose product is not a rational number?

We find that rational numbers are closed under multiplication. For any two rational numbers a and b, $a \times b$ is also rational number. i.e., $\forall a, b \in \mathbb{Q}, a \times b \in \mathbb{Q}$

(d) Division:

Consider two rational numbers.

$$\frac{2}{3}, \frac{7}{8}$$

Then $\frac{2}{3} \div \frac{7}{8} = \frac{2}{3} \times \frac{8}{7} = \frac{16}{21}$ which is a rational number

Check this for two more example.

$$\frac{5}{7} \div 2 = \frac{5}{7} \div \frac{2}{1} = \frac{5}{7} \times \frac{1}{2} = \frac{5}{14}$$

$$-\frac{2}{3} \div \frac{6}{11} = \underline{\hspace{2cm}} = \underline{\hspace{2cm}} = \underline{\hspace{2cm}}$$

$$3 \div \frac{17}{13} = \frac{3}{1} \div \frac{17}{13} = \underline{\hspace{2cm}} = \underline{\hspace{2cm}} = \underline{\hspace{2cm}}$$

From all the above, we observe that when we divide two rational numbers, we get a rational number. Now can we say that the closure property holds good for rational numbers?

Let us check the following:

0, 5 are rational numbers and $5 \div 0 = \frac{5}{0}$ is not defined. Thus collection of Rational numbers Q is not closed with respect to division.

If we exclude zero from Q then the resulting collection is closed under division.

Why $\frac{5}{0}$ is not defined?
Do the division $5 \div 0 = ?$
Or $0) 5$ (?
Can you complete the division?
What is the quotient? You may have observed that multiplication of any number with '0', the product will be '0'.
Thus division is not possible, with '0' as divisor.

 **Try These**

If we exclude zero from the set of integers then is it closed under division?

 **Do This**

Fill the blanks in the table

Numbers	Closure property under			
	Addition	Subtraction	Multiplication	Division
Natural numbers	Yes	—	—	—
Whole numbers	—	—	—	No
Integers	—	Yes	—	—
Rational numbers	—	—	Yes	—

1.2.2 Commutative Property

Let us recall the commutative property with different operations for both whole numbers and Integers.

The commutative property states that the change in the order of two numbers on binary operation does not change the result.

$$a + b = b + a$$

$$a \times b = b \times a$$

Complete the following table.

(i) Whole numbers

Operation	Example	Remark
Addition	2, 3 are whole numbers $2+3 = 5$ and $3 + 2 = 5$ $\therefore 2 + 3 = 3 + 2$	Addition is commutative in W.
Subtraction	Is $3 - 2$ equal to $2 - 3$?	Subtraction is not commutative
Multiplication	-----	-----
Division	$4 \div 2 = ?$ $2 \div 4 = ?$ Is $4 \div 2 = 2 \div 4$?	-----

(ii) Integers

Operation	Example	Remark
Addition	---	Addition is commutative in Integers.
Subtraction	2, 3 are integers $2 - (3) = ?$; $(3) - 2 = ?$ Is $2 - (3) = (3) - 2 = ?$
Multiplication
Division	Division is not Commutative in Integers

(iii) Rational Numbers

(a) Addition:

Take two rational numbers $\frac{5}{2}$, $\frac{-3}{4}$.

$$\frac{5}{2} + \frac{(-3)}{4} = \frac{2 \times 5 + 1 \times (-3)}{4} = \frac{10 - 3}{4} = \frac{7}{4}$$

$$\text{and } \frac{(-3)}{4} + \frac{5}{2} = \frac{1 \times (-3) + 2 \times 5}{4} = \frac{-3 + 10}{4} = \frac{7}{4}$$

$$\text{so } \frac{5}{2} + \left(\frac{-3}{4}\right) = \frac{-3}{4} + \frac{5}{2}$$

Now check this rule for some more pairs of rational numbers.

$$\text{Find } \frac{1}{2} + \frac{5}{7} \quad \text{and} \quad \frac{5}{7} + \frac{1}{2}.$$

$$\text{Is } \frac{1}{2} + \frac{5}{7} = \frac{5}{7} + \frac{1}{2} \quad ?$$

$$\text{Is } \frac{-2}{3} + \left(\frac{-4}{5}\right) = \frac{(-4)}{5} + \left(\frac{-2}{3}\right) \quad ?$$

Did you find any pair of rational numbers whose sum changes when we reverse the order of numbers? So, we can say that $a + b = b + a$ for any two rational numbers a and b .

Thus addition is commutative in the set of rational numbers.

$$\therefore \forall a, b \in \mathbb{Q}, a + b = b + a$$

(b) Subtraction: Take two rational numbers $\frac{2}{3}$ and $\frac{7}{8}$

$$\frac{2}{3} - \frac{7}{8} = \frac{16 - 21}{24} = \frac{-5}{24} \quad \text{and} \quad \frac{7}{8} - \frac{2}{3} = \frac{21 - 16}{24} = \frac{5}{24}$$

$$\text{So } \frac{2}{3} - \frac{7}{8} \neq \frac{7}{8} - \frac{2}{3}$$

Check the following.

$$\text{Is } 2 - \frac{5}{4} = \frac{5}{4} - 2 \quad ?$$

$$\text{Is } \frac{1}{2} - \frac{3}{5} = \frac{3}{5} - \frac{1}{2} \quad ?$$

Thus we can say that subtraction is not commutative in the set of rational numbers.

$a - b \neq b - a$ for any two rational numbers a and b .

(c) **Multiplication:** Take two rational numbers $2, -\frac{5}{7}$

$$2 \times \frac{-5}{7} = \frac{-10}{7} ; \quad \frac{-5}{7} \times 2 = \frac{-10}{7} \quad \text{therefore} \quad 2 \times \frac{-5}{7} = \frac{-5}{7} \times 2$$

$$\text{Is } \frac{-1}{2} \times \left(\frac{-3}{4}\right) = \left(\frac{-3}{4}\right) \times \left(\frac{-1}{2}\right) ?$$

Check for some more rational numbers .

We can conclude that multiplication is commutative in the set of rational numbers.

It means $a \times b = b \times a$ for any two rational numbers a and b .

i.e. $\forall a, b \in \mathbb{Q}, a \times b = b \times a$

(d) **Division:**

$$\text{Is } \frac{7}{3} \div \frac{14}{9} = \frac{14}{9} \div \frac{7}{3} ?$$

$$\frac{7}{3} \div \frac{14}{9} = \frac{7}{3} \times \frac{9}{14} = \frac{3}{2} \quad \text{and} \quad \frac{14}{9} \div \frac{7}{3} = \frac{14}{9} \times \frac{3}{7} = \frac{2}{3}$$

$$\frac{7}{3} \div \frac{14}{9} \neq \frac{14}{9} \div \frac{7}{3}$$

Thus we can say that division of rational numbers is not commutative in the set of rational numbers .



Do This

Complete the following table.

Numbers	Commutative with respect to			
	Addition	Subtraction	Multiplication	Division
Natural numbers	Yes	No	Yes	-----
Whole numbers	-----	-----	-----	No
Integers	-----	-----	-----	-----
Rational numbers	-----	-----	-----	No

1.2.3 Associative Property

Recall the associative property of whole numbers with respect to four operations, i.e. addition, subtraction, multiplication & division.

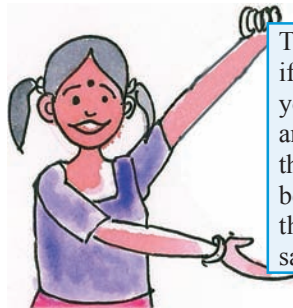

The associative property states that if you have to add three numbers, you can add the first two numbers and then add the third or you add the second and third number in the beginning and then add the first to the sum. The result will be the same i.e. $(3+2)+5 = 3+(2+5)$.

(i) Whole numbers

Complete the table with necessary illustrations and remarks.

Operation	Examples with whole numbers	Remark
Addition	$Is\ 2 + (3 + 0) = (2 + 3) + 0\ ?$ $2 + (3 + 0) = 2 + 3 = 5$ $(2 + 3) + 0 = 5 + 0 = 5$ $\Rightarrow 2 + (3 + 0) = (2 + 3) + 0$ $a + (b + c) = (a + b) + c$ for any three whole numbers a, b, c	— — — — — —
Subtraction	$(2-3) - 2 = ?; 2-(3-2) = ?$ $Is\ (2-3) - 2 = 2-(3-2)\ ?$	Subtraction is not associative
Multiplication	— — — — — — — — — — — —	Multiplication is associative
Division	$Is\ 2 \div (3 \div 5) = (2 \div 3) \div 5\ ?$ $2 \div (3 \div 5) = 2 \div \frac{3}{5} = 2 \times \frac{5}{3} = \frac{10}{3}$ $(2 \div 3) \div 5 = \frac{2}{3} \div 5 = \frac{2}{3} \times \frac{1}{5} = \frac{2}{15}$ $2 \div (3 \div 5) \neq (2 \div 3) \div 5$	Division is not associative

(ii) Integers

Recall associativity for integers under four operations.

Complete the following table with necessary remarks.

Operation	Integers with example	Remark
Addition	Is $2 + [(-3) + 5] = [(2 + (-3)) + 5]$? $2 + [(-3) + 5] = 2 + [-3 + 5] = 2 + 2 = 4$ $[2 + (-3)] + 5 = [2 - 3] + 5 = -1 + 5 = 4$ For any three integers a, b and c $a + (b + c) = (a + b) + c$	— — — — —
Subtraction	Is $6 - (9 - 5) = (6 - 9) - 5$?	— — — — —
Multiplication	Is $2 \times [7 \times (-3)] = (2 \times 7) \times (-3)$?	— — — — —
Division	$10 \div [2 \div (-5)] = [10 \div 2] \div (-5)$? $10 \div [2 \div (-5)] = 10 \div \frac{-2}{5} = 10 \times \frac{-5}{2} = -25$ Now $(10 \div 2) \div (-5) = \frac{10}{2} \div (-5) = 5 \div (-5) = \frac{5}{-5} = -1$ Thus $10 \div [2 \div (-5)] \neq [10 \div 2] \div (-5)$	— — — — —

(iii) Rational numbers

(a) Addition

Let us consider three rational numbers $\frac{2}{7}$, 5, $\frac{1}{2}$ and verify whether

$$\frac{2}{7} + \left[5 + \left(\frac{1}{2} \right) \right] = \left[\left(\frac{2}{7} + 5 \right) \right] + \left(\frac{1}{2} \right)$$

$$\text{L.H.S.} = \frac{2}{7} + \left[5 + \left(\frac{1}{2} \right) \right] = \frac{2}{7} + \left[5 + \frac{1}{2} \right] = \frac{2}{7} + \left[\frac{10+1}{2} \right] = \frac{4+77}{14} = \frac{81}{14}$$

$$\text{R.H.S.} = \left[\left(\frac{2}{7} + 5 \right) \right] + \left(\frac{1}{2} \right) = \left[\left(\frac{2+35}{7} \right) \right] + \frac{1}{2} = \frac{37}{7} + \frac{1}{2} = \frac{74+7}{14} = \frac{81}{14}$$

$$\text{L.H.S.} = \text{R.H.S.}$$

Find $\frac{1}{2} + \left[\frac{3}{7} + \frac{4}{3} \right]$ and $\left[\frac{1}{2} + \frac{3}{7} \right] + \left(\frac{4}{3} \right)$

Are the two sums equal?

Take some more rational numbers and verify the associativity.

We find rational numbers satisfy associative property under addition.

$a + (b + c) = (a + b) + c$ for any three rational numbers a, b and c .

i.e., $\forall a, b, c \in \mathbb{Q}, a + (b + c) = (a + b) + c$

(b) Subtraction

Let us take any three rational numbers $\frac{1}{2}, \frac{3}{4}$ and $\frac{-5}{4}$

Verify whether $\frac{1}{2} - \left[\frac{3}{4} - \left(\frac{-5}{4} \right) \right] = \left[\frac{1}{2} - \frac{3}{4} \right] - \left(\frac{-5}{4} \right)$

$$\begin{aligned} \text{L.H.S.} &= \frac{1}{2} - \left[\frac{3}{4} - \left(\frac{-5}{4} \right) \right] = \frac{1}{2} - \left[\frac{3}{4} + \frac{5}{4} \right] = \frac{1}{2} - \left[\frac{8}{4} \right] \\ &= \frac{1}{2} - 2 = \frac{1-4}{2} = \frac{-3}{2} \end{aligned}$$

$$\begin{aligned} \text{R.H.S.} &= \left(\frac{1}{2} - \frac{3}{4} \right) - \left(\frac{-5}{4} \right) = \left(\frac{1 \times 2 - 3}{4} \right) + \frac{5}{4} = \left(\frac{-1}{4} \right) + \frac{5}{4} \\ &= \frac{-1+5}{4} = \frac{4}{4} = 1 \end{aligned}$$

$$\therefore \frac{1}{2} - \left[\frac{3}{4} - \left(\frac{-5}{4} \right) \right] \neq \left(\frac{1}{2} - \frac{3}{4} \right) - \left(\frac{-5}{4} \right)$$

L.H.S. \neq R.H.S.

We find subtraction is not associative in the set of rational numbers. That is $a - (b - c) \neq (a - b) - c$ for any three rational numbers a, b, c .

(c) Multiplication

Take three rational numbers $\frac{2}{3}, \frac{4}{7}, \frac{-5}{7}$

$$\text{Is } \frac{2}{3} \times \left[\frac{4}{7} \times \left(\frac{-5}{7} \right) \right] = \left(\frac{2}{3} \times \frac{4}{7} \right) \times \left(\frac{-5}{7} \right) ?$$

$$\text{L.H.S.} = \frac{2}{3} \times \left[\frac{4}{7} \times \left(\frac{-5}{7} \right) \right] = \frac{2}{3} \left[\frac{-20}{49} \right] = \frac{-40}{147}$$

$$\text{R.H.S.} = \left(\frac{2}{3} \times \frac{4}{7} \right) \times \left(\frac{-5}{7} \right) = \left(\frac{8}{21} \right) \times \left(\frac{-5}{7} \right) = \frac{-40}{147}$$

L.H.S. = R.H.S

Check the following.

$$\text{Find } 2 \times \left(\frac{1}{2} \times 3\right) \text{ and } \left(2 \times \frac{1}{2}\right) \times 3$$

$$\text{Is } 2 \times \left(\frac{1}{2} \times 3\right) = \left(2 \times \frac{1}{2}\right) \times 3 ?$$

$$\text{Find } \frac{5}{3} \times \left(\frac{3}{7} \times \frac{7}{5}\right) \text{ and } \left(\frac{5}{3} \times \frac{3}{7}\right) \times \frac{7}{5}$$

$$\text{Is } \frac{5}{3} \times \left(\frac{3}{7} \times \frac{7}{5}\right) = \left(\frac{5}{3} \times \frac{3}{7}\right) \times \frac{7}{5} ?$$

We can find in all the above cases L.H.S = R.H.S

Thus multiplication is associative in rational numbers

$a \times (b \times c) = (a \times b) \times c$ for any three rational numbers a, b, c.

i.e., $\forall a, b, c \in \mathbb{Q}, a \times (b \times c) = (a \times b) \times c$

(d) Division

Take any three rational numbers $\frac{2}{3}, \frac{3}{4}$ and $\frac{1}{7}$

$$\text{Is } \frac{2}{3} \div \left(\frac{3}{4} \div \frac{1}{7}\right) = \left(\frac{2}{3} \div \frac{3}{4}\right) \div \frac{1}{7} ?$$

$$\text{L.H.S.} = \frac{2}{3} \div \left(\frac{3}{4} \div \frac{1}{7}\right) = \frac{2}{3} \div \left(\frac{3}{4} \times \frac{7}{1}\right) = \frac{2}{3} \div \frac{21}{4} = \frac{2}{3} \times \frac{4}{21} = \frac{8}{63}$$

$$\text{R.H.S.} = \left(\frac{2}{3} \div \frac{3}{4}\right) \div \frac{1}{7} = \left(\frac{2}{3} \times \frac{4}{3}\right) \div \frac{1}{7} = \left(\frac{8}{9}\right) \div \frac{1}{7} = \frac{8}{9} \times \frac{7}{1} = \frac{56}{9}$$

$$\frac{2}{3} \div \left(\frac{3}{4} \div \frac{1}{7}\right) \neq \left(\frac{2}{3} \div \frac{3}{4}\right) \div \frac{1}{7}$$

L.H.S. \neq R.H.S.

Thus $a \div (b \div c) \neq (a \div b) \div c$ for any three rational numbers a, b, c.

So, division is not associative in rational numbers.



Do This

Complete the following table

Numbers	Associative under			
	Addition	Subtraction	Multiplication	Division
Natural numbers	Yes	No
Whole numbers	No
Integers	No	Yes
Rational numbers

1.2.4 The Role of Zero

Can you find a number, when it is added to $\frac{1}{2}$ gives the same number $\frac{1}{2}$?

When the number '0' is added to any rational number, the rational number remains the same.

For example

$$1 + 0 = 1 \text{ and } 0 + 1 = 1$$

$$-2 + 0 = -2 \text{ and } 0 + (-2) = -2$$

$$\frac{1}{2} + 0 = \frac{1}{2} \text{ and } 0 + \frac{1}{2} = \frac{1}{2}$$



For this reason we call '0' as an identity element of addition or "additive identity".

If **a** represents any rational number then $a + 0 = a$ and $0 + a = a$

Does the set of natural numbers have additive identity?

1.2.5 The Role of 1

Fill in the following blanks :

$$3 \times \square = 3 \quad \text{and} \quad \square \times 3 = 3$$

$$-2 \times \square = -2 \quad \text{and} \quad \square \times -2 = -2$$

$$\frac{7}{8} \times \square = \frac{7}{8} \quad \text{and} \quad \square \times \frac{7}{8} = \frac{7}{8}$$

What observations have you made in the above multiplications?

You will find that when you multiply any rational number with '1', you will get the same rational number as the product.

We say that '1' is the multiplicative identity for rational numbers

What is the multiplicative identity for integers and whole numbers?

We often use the identity properties without realizing that we are using them.

For example when we write $\frac{15}{50}$ in the simplest form we may do the following.

$$\frac{15}{50} = \frac{3 \times 5}{10 \times 5} = \frac{3}{10} \times \frac{5}{5} = \frac{3}{10} \times 1 = \frac{3}{10}$$

When we write that $\frac{3}{10} \times 1 = \frac{3}{10}$. Here we used the identity property of multiplication.

1.2.6 Existence of Inverse

(i) Additive inverse:

$$3 + (-3) = 0 \quad \text{and} \quad -3 + 3 = 0$$

$$-5 + 5 = 0 \quad \text{and} \quad 5 + (-5) = \underline{\hspace{2cm}}$$

$$\frac{2}{3} + ? = 0 \quad \text{and} \quad \underline{\hspace{2cm}} + \frac{2}{3} = 0$$

$$\left(-\frac{1}{2}\right) + ? = 0 \quad \text{and} \quad ? + \left(-\frac{1}{2}\right) = 0$$

Here -3 and 3 are called the additive inverses of each other because on adding them we get the sum '0' i.e. the additive identity. Any two numbers whose sum is '0' are called the additive inverses of each other.

In general if a represents any rational number then $a + (-a) = 0$ and $(-a) + a = 0$. Then ' a ', ' $-a$ ' are additive inverse of each other.

The additive inverse of 0 is only 0 as $0 + 0 = 0$.

(ii) Multiplicative inverse:

By which rational number $\frac{2}{7}$ is multiplied to get the product 1 ?

$$\text{We can see } \frac{2}{7} \times \frac{7}{2} = 1 \quad \text{and} \quad \frac{7}{2} \times \frac{2}{7} = 1$$

Fill the boxes below.

$$2 \times \square = 1 \quad \text{and} \quad \square \times 2 = 1$$

$$-5 \times \square = 1 \quad \text{and} \quad \square \times 5 = 1$$

$$\frac{-17}{19} \times \square = 1 \quad \text{and} \quad \square \times \frac{-17}{19} = 1$$

$$1 \times ? = 1$$

$$-1 \times ? = 1$$

Any two numbers whose product is '1' are called the multiplicative inverses of each other.

For example, $4 \times \frac{1}{4} = 1$ and $\frac{1}{4} \times 4 = 1$, therefore the numbers 4 and $\frac{1}{4}$ are the multiplicative inverses (or the reciprocals) of each other.

We say that a rational number $\frac{c}{d}$ is called the reciprocal or the multiplicative inverse of

another rational number $\frac{a}{b}$ if $\frac{a}{b} \times \frac{c}{d} = 1$



Think, Discuss and Write

1. If a property holds good with respect to addition for rational numbers, whether it holds good for integers? And for whole numbers? Which one holds good and which doesn't hold good?
2. Write the numbers whose multiplicative inverses are the numbers themselves
3. Can you find the reciprocal of '0' (zero)? Is there any rational number such that when it is multiplied by '0' gives '1'?

$$\square \times 0 = 1 \quad \text{and} \quad 0 \times \square = 1$$

1.3 Distributivity of multiplication over addition

Take three rational numbers $\frac{2}{5}, \frac{1}{2}, \frac{3}{4}$

Let us verify whether $\frac{2}{5} \times \left(\frac{1}{2} + \frac{3}{4} \right) = \left(\frac{2}{5} \times \frac{1}{2} \right) + \left(\frac{2}{5} \times \frac{3}{4} \right)$

$$\text{L.H.S} = \frac{2}{5} \times \left(\frac{1}{2} + \frac{3}{4} \right) = \frac{2}{5} \times \left(\frac{2+3}{4} \right) = \frac{2}{5} \times \frac{5}{4} = \frac{10}{20} = \frac{1}{2}$$

$$\text{R.H.S} = \frac{2}{5} \times \left(\frac{1}{2} \right) + \frac{2}{5} \times \left(\frac{3}{4} \right) = \frac{2}{10} + \frac{6}{20} = \frac{4+6}{20} = \frac{10}{20} = \frac{1}{2}$$

$$\text{L.H.S} = \text{R.H.S}$$

Thus
$$\frac{2}{5} \times \left(\frac{1}{2} + \frac{3}{4} \right) = \left(\frac{2}{5} \right) \left(\frac{1}{2} \right) + \left(\frac{2}{5} \right) \left(\frac{3}{4} \right)$$

This property is called the distributive law of multiplication over addition.

Now verify the following.

$$\text{Is } \frac{2}{5} \times \left(\frac{1}{2} - \frac{3}{4} \right) = \frac{2}{5} \times \left(\frac{1}{2} \right) - \frac{2}{5} \times \left(\frac{3}{4} \right)$$

What do you observe? Is L.H.S = R.H.S?

This property is called the distributive law over subtraction.

Take some more rational numbers and verify the distributive property

For all rational numbers a, b and c

We can say-

$$a(b + c) = ab + ac$$

$$a(b - c) = ab - ac$$

Try these: Find using distributivity

$$(1) \left\{ \frac{7}{5} \times \left(\frac{-3}{10} \right) \right\} + \left\{ \frac{7}{5} \times \frac{9}{10} \right\}$$

$$(2) \left\{ \frac{9}{16} \times 3 \right\} + \left\{ \frac{9}{16} \times (-19) \right\}$$



Do These

Complete the following table.

Numbers	Additive properties				
	Closure	Commutative	Associative	Existence of Identity	Existence of Inverse
Rational Numbers	Yes	---	---	---	---
Integers	Yes	---	---	---	---
Whole Numbers	---	---	---	Yes	No
Natural Numbers	Yes	---	---	---	---

Complete the following table.

Numbers	Multiplicative properties				
	Closure	Commutative	Associative	Existence of Identity	Existence of Inverse
Rational Numbers	Yes	---	---	---	---
Integers	---	Yes	---	---	---
Whole Numbers	---	---	Yes	---	---
Natural Numbers	---	---	---	Yes	---

Example 1: Simplify $\frac{2}{5} + \frac{3}{7} + \left(\frac{-6}{5}\right) + \left(\frac{-13}{7}\right)$

Solution: Rearrange the given fractions keeping like fractions together.

$$\begin{aligned} \frac{2}{5} + \frac{3}{7} + \left(\frac{-6}{5}\right) + \left(\frac{-13}{7}\right) &= \frac{2}{5} + \frac{3}{7} - \frac{6}{5} - \frac{13}{7} \\ &= \left(\frac{2}{5} - \frac{6}{5}\right) + \left(\frac{3}{7} - \frac{13}{7}\right) \text{ (by commutative law of addition)} \\ &= \frac{2-6}{5} + \frac{3-13}{7} \\ &= \frac{-4}{5} + \frac{-10}{7} = \frac{-4}{5} - \frac{10}{7} \\ &= \frac{(-4 \times 7) - (10 \times 5)}{35} = \frac{-28 - 50}{35} = \frac{-78}{35} \end{aligned}$$

Example 2: Write the additive inverses of each of the following rational numbers.

(i) $\frac{2}{7}$ (ii) $\frac{-11}{5}$ (iii) $\frac{7}{-13}$ (iv) $\frac{-2}{-3}$

Solution: (i) The additive inverse of $\frac{2}{7}$ is $\frac{-2}{7}$

because $\frac{2}{7} + \left(\frac{-2}{7}\right) = \frac{2-2}{7} = 0$

(ii) The additive inverse of $\frac{-11}{5}$ is $-\left(\frac{-11}{5}\right) = \frac{11}{5}$

(iii) The additive inverse of $\frac{7}{-13}$ is $-\left(\frac{7}{-13}\right) = \frac{-7}{-13} = \frac{7}{13}$

(iv) The additive inverse of $\frac{-2}{-3}$ is $-\left(\frac{-2}{-3}\right) = -\frac{2}{3}$

Example 3: Find $\frac{2}{5} \times \frac{-1}{9} + \frac{23}{180} - \frac{1}{9} \times \frac{3}{4}$

Solution: $\frac{2}{5} \times \frac{-1}{9} + \frac{23}{180} - \frac{1}{9} \times \frac{3}{4} = \frac{2}{5} \times \frac{-1}{9} - \frac{1}{9} \times \frac{3}{4} + \frac{23}{180}$
(by the commutative law of addition)

$$= \frac{2}{5} \times \left(\frac{-1}{9}\right) + \left(\frac{-1}{9}\right) \times \frac{3}{4} + \frac{23}{180}$$

$$= \frac{-1}{9} \left(\frac{2}{5} + \frac{3}{4}\right) + \frac{23}{180}$$

$$= -\frac{1}{9} \left(\frac{8+15}{20}\right) + \frac{23}{180} \text{ (by the distributive law)}$$

$$= -\frac{1}{9} \left(\frac{23}{20}\right) + \frac{23}{180} = \frac{-23}{180} + \frac{23}{180} = 0 \text{ (by the additive inverse law)}$$

Example 4: Find the product of the reciprocals of $\frac{-9}{2}$, $\frac{5}{18}$ and add the additive inverse of

$\left(\frac{-4}{5}\right)$ to the product. What is the result?

Solution: The reciprocal of $\frac{-9}{2}$ is $\frac{-2}{9}$

The reciprocal of $\frac{5}{18}$ is $\frac{18}{5}$

$$\text{Product of reciprocals} = \frac{-2}{9} \times \frac{18}{5} = \frac{-4}{5}$$

The additive inverse of $\left(\frac{-4}{5}\right)$ is $\frac{4}{5}$

Thus the product + the additive inverse = $\frac{-4}{5} + \frac{4}{5} = 0$ (the additive Inverse property)



Exercise - 1.1

1. Name the property involved in the following examples

(i) $\frac{8}{5} + 0 = \frac{8}{5} = 0 + \frac{8}{5}$

(ii) $2\left(\frac{3}{5} + \frac{1}{2}\right) = 2\left(\frac{3}{5}\right) + 2\left(\frac{1}{2}\right)$

(iii) $\frac{3}{7} \times 1 = \frac{3}{7} = 1 \times \frac{3}{7}$

(iv) $\left(\frac{-2}{5}\right) \times 1 = \frac{-2}{5} = 1 \times \left(\frac{-2}{5}\right)$

(v) $\frac{2}{5} + \frac{1}{3} = \frac{1}{3} + \frac{2}{5}$

(vi) $\frac{5}{2} \times \frac{3}{7} = \frac{15}{14}$

(vii) $7a + (-7a) = 0$

(viii) $x \times \frac{1}{x} = 1$ ($x \neq 0$)

(ix) $(2 \times x) + (2 \times 6) = 2 \times (x + 6)$

2. Write the additive and the multiplicative inverses of the following.

(i) $\frac{-3}{5}$ (ii) 1 (iii) 0 (iv) $\frac{7}{9}$ (v) -1

3. Fill in the blanks

(i) $\left(\frac{-1}{17}\right) + (\text{---}) = \left(\frac{-12}{5}\right) + \left(\frac{-1}{17}\right)$ (ii) $\frac{-2}{3} + \text{---} = \frac{-2}{3}$

(iii) $1 \times \text{---} = \frac{9}{11}$ (iv) $-12 + \left(\frac{5}{6} + \frac{6}{7}\right) = \left(-12 + \frac{5}{6}\right) + (\text{---})$

(v) $(\text{---}) \times \left(\frac{1}{2} + \frac{1}{3}\right) = \left(\frac{3}{4} \times \frac{1}{2}\right) + \left(\frac{3}{4} \times \text{---}\right)$

(vi) $\frac{-16}{7} + \text{---} = \frac{-16}{7}$

4. Multiply $\frac{2}{11}$ by the reciprocal of $\frac{-5}{14}$
5. Which properties can be used in computing $\frac{2}{5} \times \left(5 \times \frac{7}{6}\right) + \frac{1}{3} \times \left(3 \times \frac{4}{11}\right)$
6. Verify the following and write the property used
- $$\left(\frac{5}{4} + \frac{-1}{2}\right) + \frac{-3}{2} = \frac{5}{4} + \left(\frac{-1}{2} + \frac{-3}{2}\right)$$
7. Evaluate $\frac{3}{5} + \frac{7}{3} + \left(\frac{-2}{5}\right) + \left(\frac{-2}{3}\right)$ after rearrangement.
8. Subtract
- (i) $\frac{3}{4}$ from $\frac{1}{3}$ (ii) $\frac{-32}{13}$ from 2 (iii) -7 from $\frac{-4}{7}$
9. What number should be added to $\frac{-5}{8}$ so as to get $\frac{-3}{2}$?
10. The sum of two rational numbers is 8. If one of the numbers is $\frac{-5}{6}$ find the other.
11. Is subtraction associative in rational numbers? Explain with an example.
12. Verify that $-(-x) = x$ for
- (i) $x = \frac{2}{15}$ (ii) $x = \frac{-13}{17}$
13. Write-
- (i) The set of numbers which do not have an additive identity
- (ii) The rational number that does not have any reciprocal
- (iii) The reciprocal of a negative rational number.

1.4 Representation of Rational numbers on Number line

Gayathri drew a number line and labelled some numbers on it.

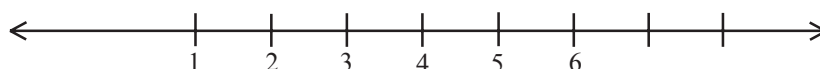

What set of numbers are marked on the line?

Sujatha said “They are Natural numbers”. Paramesh said “They are rational numbers”
Whom do you agree with?

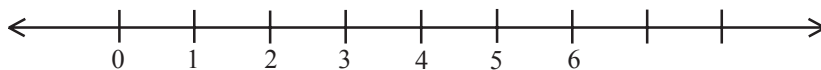

Which set of numbers are marked on the above line?

Are they whole numbers or rational numbers?

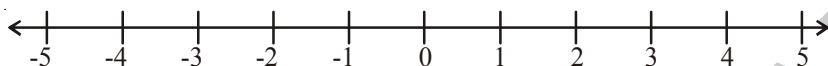

Which set of numbers are marked on the above line?

Can you find any number between -5 and 3 on the above line?

Can you see any integers between 0 and 1 or -1 and 0 in the above line?

Numbers in the middle of 0 and 1 is $\frac{1}{2}$; in the middle of 1 and 2 is $1\frac{1}{2} = \frac{3}{2}$, in the middle of 0 and -1 is $-\frac{1}{2}$ and in the middle of -1 and -2 is $-1\frac{1}{2} = -\frac{3}{2}$.

These above rational numbers can be represented on the number line as follows:

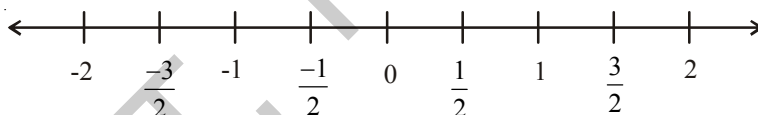

Example 5: Identify the rational numbers shown as A and B that are marked on the following number line.

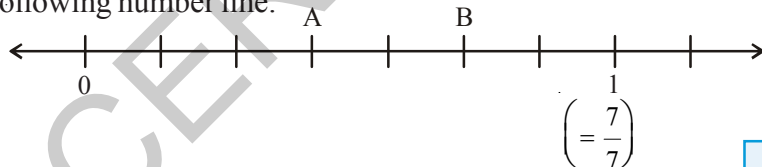

Solution: Here a unit, 0 to 1 is divided into 7 equal parts.

A is representing 3 out of 7 parts. So, A

represents $\frac{3}{7}$ and B represents $\frac{5}{7}$.

Any rational number can be represented on the number line. Notice that in a rational number the denominator tells the number of equal parts in which the each unit has been divided. The numerator tells ‘how many’ of these parts are considered.

Example 6: Represent $\frac{5}{8}$ on the number line.

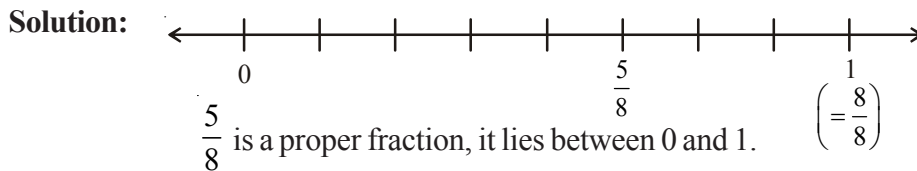

So divide the number line between 0 and 1 into 8 equal parts.

Then mark 5th part (numerator) $\frac{5}{8}$ counting from 0 is the required rational number $\frac{5}{8}$.

Example 7: Represent $\frac{29}{6}$ on the number line.

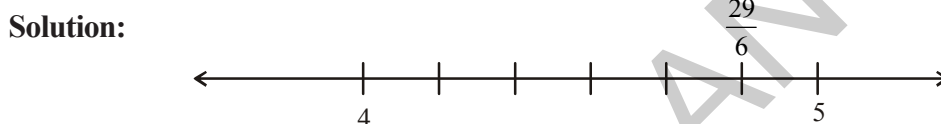

$\frac{29}{6} = 4\frac{5}{6} = 4 + \frac{5}{6}$. This lies between 4 and 5 on the number line

Divide the number line between 4 and 5 into 6 (denominator) equal parts.

Mark 5th part (numerator of rational part) counting from 4.

$$4 + \frac{5}{6} = 4\frac{5}{6} = \frac{29}{6}$$



Try These

Write the rational number for the points labelled with letters, on the number line

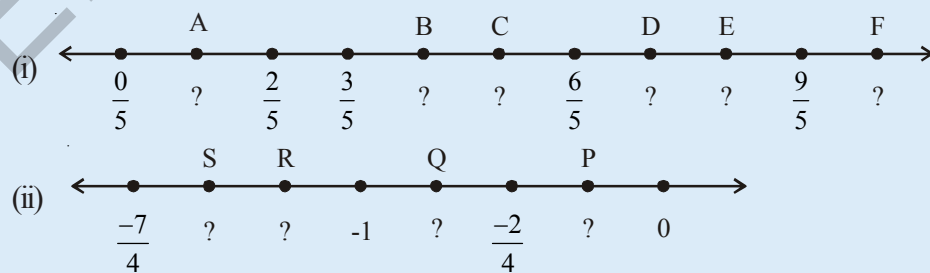

Do This

(i) Represent $-\frac{13}{5}$ on the number line.

1.5 Rational Number between Two Rational Numbers

Observe the following

The natural numbers between 1 and 5 are 2, 3, 4.

Are there any natural numbers between 1 and 2?

The integers between -4 and 3 are $-3, -2, -1, 0, 1, 2$.

Write the integers between -2 and -1 . Did you find any?

We cannot find integers between any two successive integers.

But we can write rational numbers between any two successive integers.

Let us write the rational numbers between 2 and 3.

We know if a and b are any two rational numbers then $\frac{a+b}{2}$ (and it is also called the mean of a and b) is a rational number between them. So $\frac{2+3}{2} = \frac{5}{2}$ is a rational number which lies exactly between 2 and 3.

Thus $2 < \frac{5}{2} < 3$.

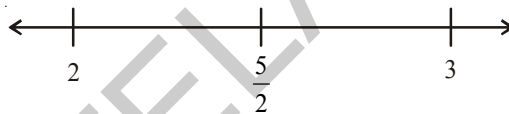

Now the rational number between 2 and $\frac{5}{2}$ is $\frac{2 + \frac{5}{2}}{2} = \frac{9}{2} = \frac{9}{2} \times \frac{1}{2} = \frac{9}{4}$.

Thus $2 < \frac{9}{4} < \frac{5}{2} < 3$

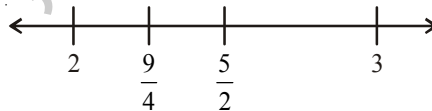

Again the mean of 2, $\frac{9}{4}$ is $\frac{2 + \frac{9}{4}}{2} = \frac{17}{4} = \frac{17}{8}$

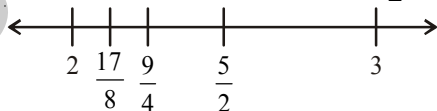

So $2 < \frac{17}{8} < \frac{9}{4} < \frac{5}{2} < 3$

In this way we can go on inserting rational numbers between any two numbers. Infact, there are infinite number of rational numbers between any two given rational numbers.

Another Method :

Can you write hundred rational numbers between $\frac{5}{10}$ and $\frac{9}{10}$ in mean method?

You may feel difficult because of the lengthy process.

Here is another method for you.

We know that $\frac{5}{10} < \frac{6}{10} < \frac{7}{10} < \frac{8}{10} < \frac{9}{10}$

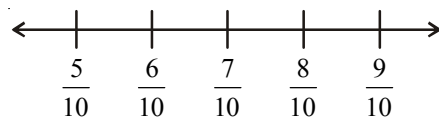

Here we can write only three rational numbers between $\frac{5}{10}$ and $\frac{9}{10}$.

But if we consider $\frac{5}{10} = \frac{50}{100}$ and $\frac{9}{10} = \frac{90}{100}$

Now the rational numbers between $\frac{50}{100}$ and $\frac{90}{100}$ are

$\frac{5}{10} = \frac{50}{100} < \frac{51}{100} < \frac{52}{100} < \frac{53}{100} < \dots < \frac{89}{100} < \frac{90}{100} = \frac{9}{10}$

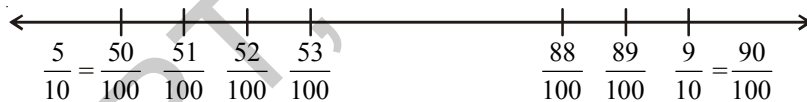

Here we can write 39 rational numbers between $\frac{5}{10}$ and $\frac{9}{10}$.

Similarly, when we consider

$\frac{5}{10} = \frac{500}{1000}$ and $\frac{9}{10} = \frac{900}{1000}$

So $\frac{5}{10} = \frac{500}{1000} < \frac{501}{1000} < \frac{502}{1000} < \frac{503}{1000} < \dots < \frac{899}{1000} < \frac{900}{1000} = \frac{9}{10}$



In this way we can go on inserting required number of rational numbers.

Example 8: Write any five rational numbers between -3 and 0 .

Solution: $-3 = -\frac{30}{10}$ and $0 = \frac{0}{10}$ so

$-\frac{29}{10}, -\frac{28}{10}, -\frac{27}{10}, \dots, -\frac{2}{10}, -\frac{1}{10}$ lies between -3 and 0 .

We can take any five of these.



Exercise - 1.2

1. Represent these numbers on the number line.

(i) $\frac{9}{7}$

(ii) $-\frac{7}{5}$

2. Represent $-\frac{2}{13}, \frac{5}{13}, \frac{-9}{13}$ on the number line.

3. Write five rational numbers which are smaller than $\frac{5}{6}$.

4. Find 12 rational numbers between -1 and 2 .

5. Find a rational number between $\frac{2}{3}$ and $\frac{3}{4}$.

[Hint : First write the rational numbers with equal denominators.]

6. Find ten rational numbers between $-\frac{3}{4}$ and $\frac{5}{6}$.

1.6 Decimal representation of Rational numbers

We know every rational number is in the form of $\frac{p}{q}$ where $q \neq 0$ and p, q are integers. Let

us see how to express a rational number in decimal form.

To convert a rational number into decimal by division method.

Consider a rational number $\frac{25}{16}$.

Step1: Divide the numerator by the denominator

$$16 \overline{)25} (1$$

Step2: Continue the division till the remainder left is less than the divisor.

$$\frac{16}{9}$$

Step3: Put a decimal point in the dividend and at the end of the quotient.

$$16 \overline{)25.0} (1.$$

Step4: Put a zero on the right of decimal point in the dividend as well as right of the remainder.

$$\frac{16}{90}$$

Divide again just as whole numbers.

Step 5: Repeat step 4 till either the remainder is zero or requisite number of decimal places have been obtained

$$16 \overline{)25.0000} (1.5625$$

$$\begin{array}{r} 16 \\ \hline 90 \\ 80 \\ \hline 100 \\ 96 \\ \hline 40 \\ 32 \\ \hline 80 \\ 80 \\ \hline 0 \end{array}$$

Therefore $\frac{25}{16} = 1.5625$

Consider $\frac{17}{5}$

$$\begin{array}{r} 5 \overline{)17.0} (3.4 \\ 15 \\ \hline 20 \\ 20 \\ \hline 0 \end{array}$$

Therefore $\frac{17}{5} = 3.4$

Try to express $\frac{1}{2}, \frac{13}{25}, \frac{8}{125}, \frac{1974}{10}$ in decimal form and write the values.

We observe that there are only finite number of digits in the decimal part of these decimal numbers. Such decimals are known as terminating decimals.

Non terminating recurring decimals:

Consider the rational number $\frac{5}{3}$

By long division method we have \longrightarrow

$$\begin{array}{r} 3 \overline{)5.000} \quad (1.666 \\ \underline{3} \\ 20 \\ \underline{18} \\ 20 \\ \underline{18} \\ 20 \\ \underline{18} \\ 2 \end{array}$$

Therefore $\frac{5}{3} = 1.666\dots$

We write this as $\frac{5}{3} = 1.\overline{6}$ the bar on '6' in the decimal part indicates it is recurring.

We observe that in the above division the same remainder is repeating itself and the digit 6 in the quotient is repeated.

Consider the rational number $\frac{1}{7} \longrightarrow$

By long division method

$$\begin{array}{r} 7 \overline{)10.00000000} \quad (0.14285714 \\ \underline{7} \\ 30 \\ \underline{28} \\ 20 \\ \underline{14} \\ 60 \\ \underline{56} \\ 40 \\ \underline{35} \\ 50 \\ \underline{49} \\ 10 \\ \underline{7} \\ 30 \\ \underline{28} \\ 2 \end{array}$$

$$\frac{1}{7} = 0.142857142857\dots$$

$\frac{1}{7} = 0.\overline{142857}$. The bar on decimal part 142857 indicates that these digits are repeating in the same order.

The above examples are illustrating the representation of rational numbers in the form of non-terminating recurring decimals or we call them as non-terminating repeating decimals.

Try to express $\frac{1}{3}$, $\frac{17}{6}$, $\frac{11}{9}$ and $\frac{20}{19}$ in decimal form

$$\frac{1}{3} = \boxed{} \quad \frac{17}{6} = \boxed{} \quad \frac{11}{9} = \boxed{} \quad \frac{20}{19} = \boxed{}$$

When we try to express some rational numbers in decimal form by division method, we find that the division never comes to an end. This is due to the reason that in the division process the remainder starts repeating after a certain number of steps. In these cases in the quotient a digit or set of digits repeats in the same order.

For example $0.33333\text{-----} = 0.\overline{3}$

$0.12757575\text{-----} = 0.12\overline{75}$

$123.121121121121\text{-----} = 123.\overline{121}$

$5.678888\text{-----} = 5.\overline{678}$ etc.

Such decimals are called non-terminating and repeating decimal or non-terminating recurring decimals.

The set of digits which repeats in non-terminating recurring decimal is called period.

For example

In $0.3333 \text{} = 0.\overline{3}$ the period is 3

In $0.12757575 \text{} = 0.12\overline{75}$ the period is 75

The number of digits in a period of non-terminating recurring decimal is called periodicity.

For example

The periodicity of $0.\overline{3}$ is 1.

The periodicity of $0.12\overline{75}$ is 2.

The period of $0.23143143143\text{.....}$ = _____ periodicity = _____

The period of 125.6788989 = _____ periodicity = _____

Think, Discuss and Write

1. Express the following in decimal form.
 - (i) $\frac{7}{5}$, $\frac{3}{4}$, $\frac{23}{10}$, $\frac{5}{3}$, $\frac{17}{6}$, $\frac{22}{7}$
 - (ii) Which of the above are terminating and which are non-terminating decimals?
 - (iii) Write the denominators of above rational numbers as the product of primes.
 - (iv) If the denominators of the above simplest rational numbers has no prime divisors other than 2 and 5 what do you observe?

1.7 Conversion of decimal form into rational form

1.7.1 Converting terminating decimal into rational form

Consider a decimal number 15.75

Find the number of places after the decimal point in the given number. In 15.75 there are 2 decimal places.

Therefore 15.75 can be written as $\frac{1575}{100}$. Now

$$\frac{1575}{100} = \frac{1575 \div 5}{100 \div 5} = \frac{315 \div 5}{20 \div 5} = \frac{63}{4}$$

$\frac{63}{4}$ is the rational form of 15.75.

Example 9: Express each of the following decimals in the $\frac{p}{q}$ form

- (i) 0.35 (ii) -8.005 (iii) 2.104

Solution: (i) Since 0.35 has two places after decimal point. It is written as $0.35 = \frac{35}{100}$.

$$\text{Now, } 0.35 = \frac{35}{100} = \frac{35 \div 5}{100 \div 5} = \frac{7}{20}$$

$$\text{(ii) } -8.005 = \frac{-8005}{1000} = \frac{-8005 \div 5}{1000 \div 5} = \frac{-1601}{200}$$

$$\text{(iii) } 2.104 = \frac{2104}{1000} = \frac{2104 \div 4}{1000 \div 4} = \frac{526 \div 2}{250 \div 2} = \frac{263}{125}$$

1.7.2 Converting a non-terminating recurring decimal into rational form

Let us discuss the method of conversion by following example.

Example 10: Express each of the following decimals numbers in the rational form.

- (i) $0.\bar{4}$ (ii) $0.\bar{54}$ (iii) $4.\bar{7}$

Solution (i): $0.\bar{4}$

$$\text{Let } x = 0.\bar{4}$$

$$\Rightarrow x = 0.444 \dots \text{-----(i)}$$

Here the periodicity of the decimal is one.

So we multiply both sides of (i) by 10 and we get

$$10x = 4.44 \dots \text{-----(ii)}$$

Subtracting (i) from (ii)

$$\begin{array}{r} 10x = 4.444\dots \\ x = 0.444\dots \\ \hline 9x = 4.000\dots \\ \hline x = \frac{4}{9} \end{array}$$

Hence $0.\overline{4} = \frac{4}{9}$

Observe

$$0.\overline{4} = \frac{4}{9}$$

$$0.\overline{5} = \frac{5}{9}$$

$$0.\overline{54} = \frac{54}{99}$$

$$0.\overline{745} = \frac{745}{999}$$

Solution (ii): $0.\overline{54}$

let $x = 0.\overline{54}$

$$\Rightarrow x = 0.545454\dots \text{----- (i)}$$

here the periodicity of the decimal is two.

So we multiply both sides of (i) by 100, we get

$$100x = 54.5454\dots \text{----- (ii)}$$

On subtracting (i) from (ii)

$$\begin{array}{r} 100x = 54.5454 \dots \\ x = 0.5454 \dots \\ \hline 99x = 54.0000\dots \\ \hline x = \frac{54}{99} \end{array}$$

Hence $0.\overline{54} = \frac{54}{99}$

Solution (iii): $4.\overline{7}$

let $x = 4.\overline{7}$

$$x = 4.777\dots \text{----- (i)}$$

here the periodicity of the decimal is one.

So multiply both sides of (i) by 10, we get

$$10x = 47.777\dots \text{----- (ii)}$$

Subtracting (i) from (ii) we get

$$\begin{array}{r} 10x = 47.777 \dots \\ x = 4.777 \dots \\ \hline 9x = 43.000\dots \end{array}$$

$$x = \frac{43}{9}$$

$$\text{Hence } 4.\bar{7} = \frac{43}{9}$$

Alternative Method: $4.\bar{7} = 4 + 0.\bar{7}$

$$= 4 + \frac{7}{9}$$

$$= \frac{9 \times 4 + 7}{9}$$

$$\therefore 4.\bar{7} = \frac{43}{9}$$

Example 11: Express the mixed recurring decimal $15.7\bar{3}2$ in $\frac{p}{q}$ form.

Solution : Let $x = 15.7\bar{3}2$

$$x = 15.7323232\dots \text{-----(i)}$$

Since two digits 32 are repeating therefore the periodicity of the above decimal is two.

So multiply (i) both sides by 100, we get

$$100x = 1573.2323\dots \text{-----(ii)}$$

Subtracting (i) from (ii), we get

$$100x = 1573.232323\dots$$

$$x = 15.732323\dots$$

$$99x = 1557.50000$$

$$x = \frac{1557.5}{99} = \frac{15575}{990}$$

$$= 15.\bar{7}32 = \frac{15575}{990}$$



Think, Discuss and Write

Convert the decimals $0.\bar{9}$, $14.\bar{5}$ and $1.2\bar{4}$ to rational form. Can you find any easy method other than formal method?



Exercise - 1.3

- Express each of the following decimal in the $\frac{p}{q}$ form.
(i) 0.57 (ii) 0.176 (iii) 1.00001 (iv) 25.125
- Express each of the following decimals in the rational form ($\frac{p}{q}$).
(i) $0.\overline{9}$ (ii) $0.\overline{57}$ (iii) $0.\overline{729}$ (iv) $12.\overline{28}$
- Find $(x + y) \div (x - y)$ if
(i) $x = \frac{5}{2}, y = -\frac{3}{4}$ (ii) $x = \frac{1}{4}, y = \frac{3}{2}$
- Divide the sum of $-\frac{13}{5}$ and $\frac{12}{7}$ by the product of $-\frac{13}{7}$ and $-\frac{1}{2}$.
- If $\frac{2}{5}$ of a number exceeds $\frac{1}{7}$ of the same number by 36. Find the number.
- Two pieces of lengths $2\frac{3}{5}$ m and $3\frac{3}{10}$ m are cut off from a rope 11 m long. What is the length of the remaining rope?
- The cost of $7\frac{2}{3}$ meters of cloth is ₹ $12\frac{3}{4}$. Find the cost per metre.
- Find the area of a rectangular park which is $18\frac{3}{5}$ m long and $8\frac{2}{3}$ m broad.
- What number should $-\frac{33}{16}$ be divided by to get $-\frac{11}{4}$?
- If 36 trousers of equal sizes can be stitched with 64 meters of cloth. What is the length of the cloth required for each trouser?
- When the repeating decimal $0.363636 \dots$ is written in simplest fractional form $\frac{p}{q}$, find the value of $p + q$.



What we have discussed

- Rational numbers are closed under addition, subtraction and multiplication.
- The addition and multiplications are
 - Commutative for rational numbers
 - Associative for rational numbers
- '0' is the additive identity for rational numbers.
- '1' is the multiplicative identity for rational numbers.
- A rational number and its additive inverse are opposite in their sign.
- The multiplicative inverse of a rational number is its reciprocal.
- Distributivity of rational numbers a, b and c ,
 $a(b + c) = ab + ac$ and $a(b - c) = ab - ac$
- Rational numbers can be represented on a number line
- There are infinite rational numbers between any two given rational numbers. The concept of mean help us to find rational numbers between any two rational numbers.
- The decimal representation of rational numbers is either in the form of terminating decimal or non-terminating recurring decimals.



Can you find?

Guess a formula for a_n . Use the subdivided unit square below to give a visual justification of your conjecture.

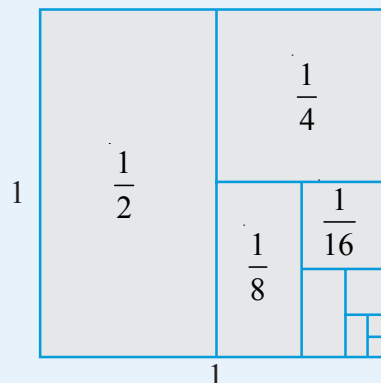

Hint : $a_1 = \frac{1}{2}$, $a_2 = \frac{1}{2} + \frac{1}{4}$, $a_3 = \frac{1}{2} + \frac{1}{4} + \frac{1}{8}$ $a_n = \frac{1}{2} + \frac{1}{4} + \dots + \frac{1}{2^n}$

$a_1 = 1 - \frac{1}{2}$, $a_2 = 1 - \frac{1}{4}$, $a_3 = 1 - \frac{1}{8}$ then $a_n = ?$

Linear Equations in One Variable



2.0 Introduction

Sagar and Latha are playing with numbers. Sagar tells Latha “I think of a number. If I double it and take 7 away I get 35. Can you tell the number that I thought of?” Latha thinks for a while and tells the answer. Can you too tell the answer?



Let us see how Latha told the answer. Let the number be ‘ x ’.

By doubling it we get ‘ $2x$ ’

Next 7 was subtracted from ‘ $2x$ ’. After subtraction, the resulting number is $2x - 7$

But according to Sagar it is equal to 35

$$\Rightarrow 2x - 7 = 35$$

$$\therefore 2x = 35 + 7 \text{ (Transposing 7 to RHS)}$$

$$2x = 42$$

$$\therefore x = \frac{42}{2} \text{ (Transposing 2 to RHS)}$$

$$\therefore x = 21$$

\therefore The number that Sagar thought of is 21.

Trick

Take the final result. Add 7 to it and then halve the result.

Note

When we transpose terms
 ‘+’ quantity becomes ‘-’ quantity
 ‘-’ quantity becomes ‘+’ quantity
 ‘ \times ’ quantity becomes ‘ \div ’ quantity
 ‘ \div ’ quantity becomes ‘ \times ’ quantity

We learnt in earlier classes that $2x - 7 = 35$ is an example of an equation. By solving this equation in the above method, Latha was able to find the number that Sagar thought of.

In this chapter we will discuss about linear equations in one variable or simple equations, technique of solving such equations and its application in daily life problems.

Let us briefly revise what we know about equations.

- (i) An algebraic equation is equality of algebraic expressions involving variables and constants

$$\begin{array}{ccc} \textcircled{2x - 7} & = & \textcircled{35} \\ \downarrow & & \downarrow \\ \text{L.H.S} & & \text{R.H.S} \end{array}$$

- (ii) It has an equality sign
- (iii) The expression on the left of the equality sign is called the L.H.S (Left Hand Side) of the equation
- (iv) The expression on the right of the equality sign is called R.H.S (Right Hand Side) of the equation
- (v) In an equation, the values of LHS and RHS are equal. This happens to be true only for certain value of the Variable. This value is called the solution of the equation.

$$\begin{aligned}
 2x - 7 &= 35 \text{ is true} \\
 \text{for } x &= 21 \text{ only} \\
 \text{i.e., if } x &= 21 \\
 \text{LHS} &= 2x - 7 \\
 &= 2 \times 21 - 7 \\
 &= 35 \\
 &= \text{RHS} \\
 \therefore \text{Solution is } x &= 21
 \end{aligned}$$

2.1 Linear Equations

Consider the following equations:

$$(1) 2x - 7 = 35 \quad (2) 2x + 2y = 48 \quad (3) 4x - 1 = 2x + 5 \quad (4) x^2 + y = z$$

Degree of each equation (1), (2) and (3) is one. So they are called linear equations. While degree of equation (4) is not one. So it is not a linear equation.

So equations (1), (2) and (3) are examples of linear equations.



Do This

Which of the following are linear equations:

- (i) $4x + 6 = 8$
- (ii) $4x - 5y = 9$
- (iii) $5x^2 + 6xy - 4y^2 = 16$
- (iv) $xy + yz + zx = 11$
- (v) $3x + 2y - 6 = 0$
- (vi) $3 = 2x + y$
- (vii) $7p + 6q + 13s = 11$

2.2 Simple equations or Linear equations in one variable

Consider the following equations:

$$(i) 2x - 7 = 35 \quad (ii) 4x - 1 = 2x + 5 \quad (iii) 2x + 2y = 48$$

We have just learnt that these are examples of linear equations. Observe the number of variables in each equation.

(i) and (ii) are examples of linear equations in one variable. But the (iii) equation has two variables 'x' and 'y'. So this is called linear equation in two variables.

Thus an equation of the form $ax + b = 0$ or $ax = b$ where a, b are constants and $a \neq 0$ is called linear equation in one variable or simple equation.



Do This

Which of the following are simple equations?

- (i) $3x + 5 = 14$ (ii) $3x - 6 = x + 2$ (iii) $3 = 2x + y$
 (iv) $\frac{x}{3} + 5 = 0$ (v) $x^2 + 5x + 3 = 0$ (vi) $5m - 6n = 0$
 (vii) $7p + 6q + 13s = 11$ (viii) $13t - 26 = 39$

2.3 Solving Simple equation having the variable on one side

Let us recall the technique of solving simple equations (having the variable on one side). Using the same technique Latha was able to solve the puzzle and tell the number that Sagar thought of.

Example 1: Solve the equation $3y + 39 = 8$

Solution: Given equation : $3y + 39 = 8$
 $3y = 8 - 39$ (Transposing 39 to RHS)
 $3y = -31$
 $y = \frac{-31}{3}$ (Transposing 3 to RHS)
 \therefore The solution of $3y + 39 = 8$ is $y = \frac{-31}{3}$

Do you notice that the solution ($\frac{-31}{3}$) is a rational number?

Check: LHS = $3y + 39 = 3 \left(\frac{-31}{3}\right) + 39 = -31 + 39 = 8$ RHS

Example 2: Solve $\frac{7}{4} - p = 11$

Solution: $\frac{7}{4} - p = 11$

Say True or false? Justify your answer?

While solving an equation Kavya does the following:

$$3x + x + 5x = 72$$

$$9x = 72, x = 72 \times 9 = 648$$

Where has she gone wrong? Find the correct answer?

$$-p = 11 - \frac{7}{4} \quad (\text{Transposing } \frac{7}{4} \text{ to RHS})$$

$$-p = \frac{44 - 7}{4}$$

$$-p = \frac{37}{4}$$

$$\therefore p = -\frac{37}{4} \quad (\text{Multiplying both sides by } -1)$$

Transpose p from LHS to RHS and find the value of p .

Is there any change in the value of p ?

$$\text{Check: LHS} = \frac{7}{4} - p = \frac{7}{4} - \left(-\frac{37}{4}\right) = \frac{7}{4} + \frac{37}{4} = \frac{7+37}{4} = \frac{44}{4} = 11 = \text{RHS}$$



Exercise - 2.1

Solve the following Simple Equations:

(i) $6m = 12$

(ii) $14p = -42$

(iii) $-5y = 30$

(iv) $-2x = -12$

(v) $34x = -51$

(vi) $\frac{n}{7} = -3$

(vii) $\frac{2x}{3} = 18$

(viii) $3x + 1 = 16$

(ix) $3p - 7 = 0$

(x) $13 - 6n = 7$

(xi) $200y - 51 = 49$

(xii) $11n + 1 = 1$

(xiii) $7x - 9 = 16$

(xiv) $8x + \frac{5}{2} = 13$

(xv) $4x - \frac{5}{3} = 9$

(xvi) $x + \frac{4}{3} = 3\frac{1}{2}$

2.3.1 Some Applications

Consider the following examples:

Example 3: If $l \parallel m$, find the value of 'x'?

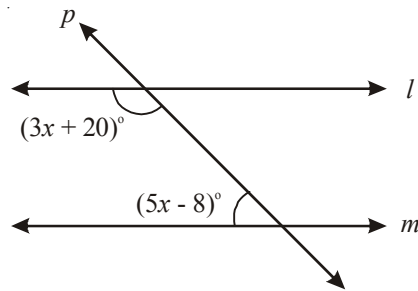

Solution: Here $l \parallel m$ and p is transversal.

Therefore $(3x + 20)^\circ + (5x - 8)^\circ = 180^\circ$ (sum of the interior angles on the same side of a transversal)

$$3x + 20^\circ + 5x - 8^\circ = 180^\circ$$

$$8x + 12^\circ = 180^\circ$$

$$8x = 180^\circ - 12^\circ$$

$$8x = 168^\circ$$

$$x = \frac{168^\circ}{8} = 21^\circ$$

Example 4: Sum of two numbers is 29 and one number exceeds another by 5. Find the numbers.

Solution: We have a puzzle here. We don't know the numbers. We have to find them.

Let the smaller number be 'x', then the bigger number will be 'x + 5'.

But it is given that sum of these two numbers is 29

$$\Rightarrow x + x + 5 = 29$$

$$\Rightarrow 2x + 5 = 29$$

$$\therefore 2x = 29 - 5$$

$$\therefore 2x = 24$$

$$x = \frac{24}{2} \quad (\text{Transposing '2' to RHS})$$

$$x = 12.$$

Therefore smaller number : $x = 12$ and

Bigger number : $x + 5 = 12 + 5 = 17$.

Check: 17 exceeds 12 by 5 and $12 + 17 = 29$.

Example 5: Four times a number reduced by 5 equals 19. Find the number.

Solutions: If the number is taken to be 'x', then four times of the number is '4x'

When 4x is reduced by 5 it equals to 19

$$\Rightarrow 4x - 5 = 19$$

$$4x = 19 + 5 \quad (\text{Transposing } -5 \text{ to RHS})$$

$$4x = 24$$

$$\therefore x = \frac{24}{4} \quad (\text{Transposing } 4 \text{ to RHS})$$

$$\Rightarrow x = 6$$

Hence the required number is 6

Check: 4 times of 6 is 24 and $24 - 5 = 19$.

Example 6: The length of a rectangle shaped park exceeds its breadth by 17 meters. If the perimeter of the park is 178 meters find the dimensions of the park?

Solution: Let the breadth of the park = x meters

Then the length of the park = $x + 17$ meters

$$\therefore \text{perimeter of the park} = 2 (\text{length} + \text{breadth})$$

$$= 2 (x + 17 + x) \text{ meters}$$

$$= 2 (2x + 17) \text{ meters}$$

But it is given that the perimeter of the rectangle is 178 meters

$$\therefore 2 (2x + 17) = 178$$

$$4x + 34 = 178$$

$$4x = 178 - 34$$

$$4x = 144$$

$$x = \frac{144}{4} = 36$$

Therefore, breadth of the park = 36 meters

Length of the park = $36 + 17 = 53$ meters.

Try and Check it on your own.

Example 7: Two supplementary angles differ by 34. Find the angles

Solution: Let the smaller angle be x°

Since the two angles differ by 34° , the bigger angle = $x + 34^\circ$

Since the sum of the supplementary angles is 180°

$$x^\circ + (x^\circ + 34) = 180^\circ$$

$$2x^\circ + 34 = 180^\circ$$

$$2x = 180 - 34 = 146^\circ$$

$$x^\circ = \frac{146^\circ}{2} = 73^\circ$$

Therefore smaller angle = $x^\circ = 73^\circ$

Bigger angle = $x^\circ + 34^\circ = 73^\circ + 34^\circ = 107^\circ$

Example 8: The present age of Vijaya's mother is four times the present age of Vijaya. After 6 years the sum of their ages will be 62 years. Find their present ages.

Solution: Let Vijaya's present age be ' x ' years

Then we can make the following table

	Vijaya	Vijaya's mother
Present age	x	$4x$
Age after 6 years	$x + 6$	$4x + 6$

$$\begin{aligned}\therefore \text{Sum of their ages after 6 years} &= (x + 6) + (4x + 6) \\ &= x + 6 + 4x + 6 \\ &= 5x + 12\end{aligned}$$

But it is given that sum of their ages after 6 years is 62

$$\Rightarrow 5x + 12 = 62$$

$$5x = 62 - 12$$

$$5x = 50$$

$$x = \frac{50}{5} = 10$$

Therefore, present age of Vijaya = $x = 10$ years

Present age of Vijaya's mother = $4x = 4 \times 10 = 40$ years

Example 9 : There are 90 multiple choice questions in a test. Two marks are awarded for every correct answer and one mark is deducted for every wrong answer. If Sahana got 60 marks in the test while she answered all the questions, then how many questions did she answer correctly?

Solution: Suppose the number of correctly answered questions be ' x ', then number of wrongly answer questions = $90 - x$.

It is given that for every correct answer 2 marks are awarded.

\therefore Number of marks scored for correct answers = $2x$

And it is given that for every wrongly answered questions '1' mark is deducted

\therefore Number of marks to be deducted from the score = $(90-x) \times 1 = 90 - x$

\therefore Total score = $2x - (90 - x) = 2x - 90 + x = 3x - 90$

But it is given that total score is 60

$$\Rightarrow 3x - 90 = 60$$

$$3x = 60 + 90$$

$$3x = 150$$

$$x = \frac{150}{3} = 50$$

\therefore Number of questions answered correctly = $x = 50$

Example 10: Ravi works as a cashier in a bank. He has currency of denominations ₹ 100, ₹ 50, ₹ 10 respectively. The ratio of number of these notes is 2 : 3 : 5. The total cash with Ravi is ₹ 4,00,000.

How many notes of cash of each denomination does he have?

Solution: Let the number of ₹ 100 notes = $2x$

Number of ₹ 50 notes = $3x$

and Number of ₹ 10 notes = $5x$

\therefore Total Money = $(2x \times 100) + (3x \times 50) + (5x \times 10)$

$$= 200x + 150x + 50x = 400x$$

Note that $2x : 3x : 5x$
is same as $2 : 3 : 5$



But according to the problem the total money is Rs.4, 00,000.

$$\Rightarrow 400x = 4, 00,000$$

$$x = \frac{400000}{400} = 1000$$

Therefore number of ₹100 notes = $2x = 2 \times 1000 = 2000$

Number of ₹ 50 notes = $3x = 3 \times 1000 = 3000$

Number of ₹10 notes = $5x = 5 \times 1000 = 5000$



Exercise - 2.2

1. Find 'x' in the following figures?

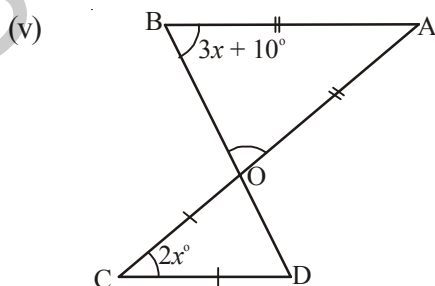
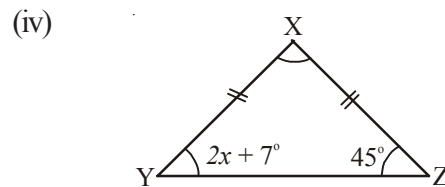
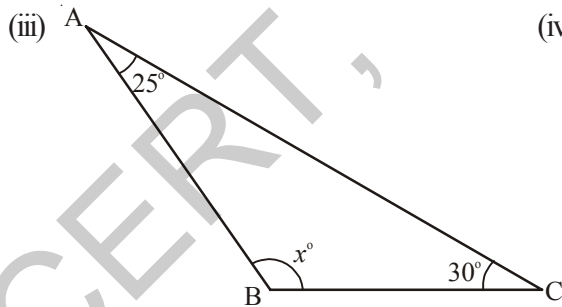
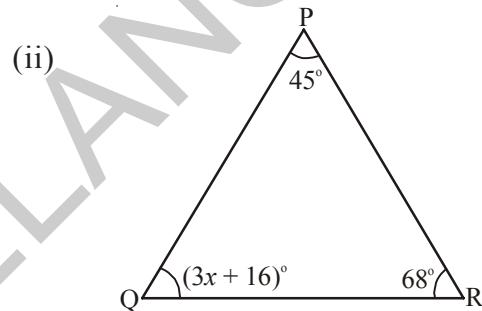
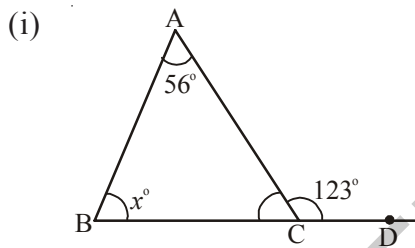

2. The difference between two numbers is 8. If 2 is added to the bigger number the result will be three times the smaller number. Find the numbers.
3. What are those two numbers whose sum is 58 and difference is 28?
4. The sum of two consecutive odd numbers is 56. Find the numbers.
5. The sum of three consecutive multiples of 7 is 777. Find these multiples.
(Hint: Three consecutive multiples of 7 are ' x ', ' $x + 7$ ', ' $x + 14$ ')
6. A man walks 10 km, then travels a certain distance by train and then by bus as far as twice by the train. If the whole journey is of 70km, how far did he travel by train?
7. Vinay bought a cake and cut it into three pieces. When he weighed the first piece he found that it was 7g lighter than the second piece and 4g heavier than the third piece. If the whole cake weighed 300g. How much did each of the three pieces weigh?

8. The distance around a rectangular field is 400 meters. The length of the field is 26 meters more than the breadth. Calculate the length and breadth of the field?
9. The length of a rectangular field is 8 meters less than twice its breadth. If the perimeter of the rectangular field is 56 meters, find its length and breadth?
10. Two equal sides of a triangle are each 5 meters less than twice the third side. If the perimeter of the triangle is 55 meters, find the length of its sides?
11. Two complementary angles differ by 12° , find the angles?
12. The ages of Rahul and Laxmi are in the ratio 5:7. Four years later, the sum of their ages will be 56 years. What are their present ages?
13. There are 180 multiple choice questions in a test. A candidate gets 4 marks for every correct answer, and for every un-attempted or wrongly answered questions one mark is deducted from the total score of correct answers. If a candidate scored 450 marks in the test how many questions did he answer correctly?
14. A sum of ₹ 500 is in the form of denominations of ₹ 5 and ₹ 10. If the total number of notes is 90 find the number of notes of each denomination.

(Hint: let the number of 5 rupee notes be ' x ', then number of 10 rupee notes = $90 - x$)

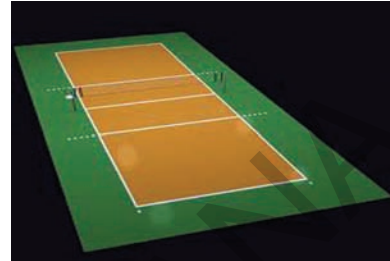
15. A person spent ₹ 564 in buying pens and pencils if cost of each pen is ₹ 7 and each pencil is ₹ 3 and if the total number of things bought was 108, how many of each type did he buy?

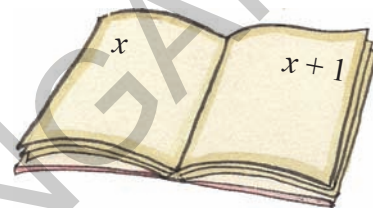

16. The perimeter of a school volleyball court is 177 ft and the length is twice the width. What are the dimensions of the volleyball court?



17. The sum of the page numbers on the facing pages of a book is 373. What are the page numbers?

(Hint :Let the page numbers of open pages are x and $x+1$)

2.4 Solving equation that has variables on both the sides

We know that an equation is the equality of the values of two expressions. In the equation $2x - 7 = 35$, the two expressions are $2x-7$ and 35 . In most examples that we have come across so far the RHS is just a number. But it need not be always. So, both sides could have expressions with variables. Let us see how this happens.

Consider the following example

Example 11: The present ages of Rafi and Fathima are in the ratio $7 : 5$. Ten years later the ratio of their ages will be $9 : 7$. Find their present ages?

Solution: Since the present ratios of ages of Rafi and Fathima is $7:5$, we may take, Rafi's age to be $7x$ and the Fathima's age to be $5x$

(Note that ratio of $7x$ and $5x$ is $7x : 5x$ and which is same as $7:5$)

After 10 years Rafi's age = $7x + 10$

and Fathima's age = $5x + 10$

After 10 years, the ratio of Rafi's age and Fathima's age is $7x + 10 : 5x + 10$

But according to the given data this ratio is equal to $9 : 7$

$$\Rightarrow 7x + 10 : 5x + 10 = 9 : 7$$

$$\text{i.e., } 7(7x + 10) = 9(5x + 10)$$

$$\Rightarrow 49x + 70 = 45x + 90.$$

Did you notice that in the above equation we have algebraic expressions on both sides? Now let us learn how to solve such equations.

The above equation is $49x + 70 = 45x + 90$

$$\Rightarrow 49x - 45x = 90 - 70 \quad (\text{Transposing } 70 \text{ to RHS and } 45x \text{ to LHS})$$

$$\therefore 4x = 20$$

$$\therefore x = \frac{20}{4} = 5$$

Therefore Rafi's age = $7x = 7 \times 5 = 35$ years

And Fathima's age = $5x = 5 \times 5 = 25$ years

Example 12: Solve $5(x + 2) - 2(3 - 4x) = 3(x + 5) - 4(4 - x)$

Solution : $5x + 10 - 6 + 8x = 3x + 15 - 16 + 4x$ (removing brackets)

$$13x + 4 = 7x - 1$$
 (adding like terms)

$$13x - 7x = -1 - 4$$
 (transposing 4 to RHS, 7x to LHS)

$$6x = -5$$

$$x = \frac{-5}{6}$$
 (transposing 6 to RHS)



Exercise - 2.3

Solve the following equations:

1. $7x - 5 = 2x$
2. $5x - 12 = 2x - 6$
3. $7p - 3 = 3p + 8$
4. $8m + 9 = 7m + 8$
5. $7z + 13 = 2z + 4$
6. $9y + 5 = 15y - 1$
7. $3x + 4 = 5(x - 2)$
8. $3(t - 3) = 5(2t - 1)$

9. $5(p - 3) = 3(p - 2)$
10. $5(z + 3) = 4(2z + 1)$
11. $15(x - 1) + 4(x + 3) = 2(7 + x)$
12. $3(5z - 7) + 2(9z - 11) = 4(8z - 7) - 111$
13. $8(x - 3) - (6 - 2x) = 2(x + 2) - 5(5 - x)$
14. $3(n - 4) + 2(4n - 5) = 5(n + 2) + 16$

2.4.1 Some more applications

Example 13: In the figure $l \parallel m$, and p a transversal find the value of 'x'?

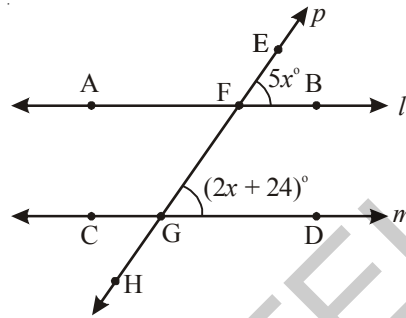

Solution: It is given that $l \parallel m$ and p is a transversal.

$\therefore \angle EFB = \angle FGD$ (corresponding angles)

$$\therefore 5x^\circ = (2x + 24)^\circ$$

$$5x^\circ - 2x^\circ = 24^\circ$$

$$3x^\circ = 24^\circ$$

$$x = \frac{24}{3} = 8^\circ$$

Example 14: Hema is 24 years older than her daughter Dhamini. 6 years ago, Hema was thrice as old as Dhamini. Find their present ages.

Solution: Let the Present age of Dhamini be 'x' years, then we can make the following table.

	Dhamini	Hema
Present age	x	$x + 24$
6 years ago	$x - 6$	$(x + 24) - 6 = x + 24 - 6 = x + 18$

But as given that 6 years ago Hema was thrice as old as Dhamini

$$\therefore x + 18 = 3(x - 6)$$

$$x + 18 = 3x - 18$$

$$x - 3x = -18 - 18$$

$$-2x = -36$$

$$x = 18.$$

Therefore present age of Dhamini = $x = 18$ years

Present age of Hema = $x + 24 = 18 + 24 = 42$ years

Example 15: In a two digit number the sum of the two digits is 8. If 18 is added to the number its digits are reversed. Find the number.

Solution: Let the digit at ones place be 'x'

Then the digit at tens place = $8 - x$. (sum of the two digits is 8)

Therefore number $10(8 - x) + x = 80 - 10x + x = 80 - 9x$ ——— (1)

Now, number obtained by reversing the digits = $10 \times (x) + (8 - x)$
 $= 10x + 8 - x = 9x + 8$

It is given that if 18 is added to the number its digits are reversed

\therefore Number + 18 = Number obtained by reversing the digits

$$\Rightarrow (80 - 9x) + 18 = 9x + 8$$

$$98 - 9x = 9x + 8$$

$$98 - 8 = 9x + 9x$$

$$90 = 18x$$

$$x = \frac{90}{18} = 5$$

By substituting the value of x in equation (1) we get the number

\therefore Number = $80 - 9 \times 5 = 80 - 45 = 35$.

Example 16: A motorboat goes down stream in a river and covers the distance between two coastal towns in five hours. It covers this distance upstream in six hours. If the speed of the stream is 2 km/hour find the speed of the boat in still water.



Solution: Since we have to find the speed of the boat in still water, let us suppose that it is x km/h.

This means that while going downstream the speed of the boat will be $(x + 2)$ kmph because the water current is pushing the boat at 2 kmph in addition to its own speed 'x' kmph. Now the speed of the boat downstream = $(x + 2)$ kmph

\therefore Distance covered in 5 hours = $5(x + 2)$ km

Hence the distance between A and B is $5(x + 2)$ km

But while going upstream the boat has to work against the water current. Therefore its speed upstream will be $(x - 2)$ kmph.

Distance covered in 6 hours = $6(x - 2)$ km

\therefore Distance between A and B is $6(x - 2)$ km

But the distance between A and B is fixed

$$\therefore 5(x + 2) = 6(x - 2)$$

$$\Rightarrow 5x + 10 = 6x - 12$$

$$\Rightarrow 5x - 6x = -12 - 10$$

$$\therefore -x = -22$$

$$x = 22.$$

Therefore speed of the boat in still water is 22 kmph.

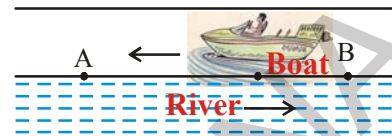
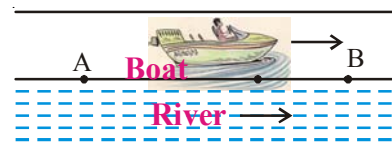

Exercise- 2.4

- Find the value of 'x' so that $l \parallel m$.

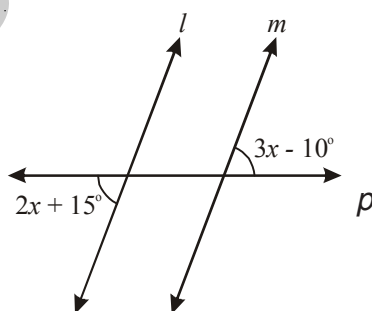

2. Eight times of a number reduced by 10 is equal to the sum of six times the number and 4. Find the number.
3. A number consists of two digits whose sum is 9. If 27 is subtracted from the number its digits are reversed. Find the number.
4. A number is divided into two parts such that one part is 10 more than the other. If the two parts are in the ratio 5:3, find the number and the two parts.
5. When I triple a certain number and add 2, I get the same answer as I do when I subtract the number from 50. Find the number.
6. Mary is twice older than her sister. In 5 years time, she will be 2 years older than her sister. Find how old are they both now.
7. In 5 years time, Reshma will be three times old as she was 9 years ago. How old is she now?
8. A town's population increased by 1200 people, and then this new population decreased 11%. The town now had 32 less people than it did before the 1200 increase. Find the original population.

2.5 Reducing Equations

Example 17: Solve $\frac{x}{2} - \frac{1}{4} = \frac{x}{3} + \frac{1}{2}$

Solution:

$$\frac{x}{2} - \frac{1}{4} = \frac{x}{3} + \frac{1}{2}$$

$$\frac{x}{2} - \frac{x}{3} = \frac{1}{2} + \frac{1}{4}$$

$$\frac{3x - 2x}{6} = \frac{2 + 1}{4}$$

$$\frac{x}{6} = \frac{3}{4}$$

$$\therefore x = \frac{3}{4} \times 6$$

$$\therefore x = \frac{9}{2}$$

$$\therefore x = \frac{9}{2} \text{ is the solution of the given equation.}$$

(Transposing $\frac{x}{3}$ to L.H.S. and $\frac{1}{4}$ to R.H.S.)

(LCM of 2 and 3 is 6 ; 2 and 4 is 4)

(Transposing 6 to R.H.S.)

Example 18: Solve $\frac{x-4}{7} - \frac{x+4}{5} = \frac{x+3}{7}$

Solution : $\frac{x-4}{7} - \frac{x+4}{5} = \frac{x+3}{7}$

$$\frac{5(x-4) - 7(x+4)}{35} = \frac{x+3}{7}$$

$$\frac{5x - 20 - 7x - 28}{35} = \frac{x+3}{7}$$

$$\frac{-2x - 48}{35} = \frac{x+3}{7}$$

$$-2x - 48 = \frac{(x+3)}{7} \times 35$$

$$\Rightarrow -2x - 48 = (x+3) \times 5$$

$$\Rightarrow -2x - 48 = 5x + 15$$

$$\Rightarrow -2x - 5x = 15 + 48$$

$$-7x = 63$$

$$x = \frac{63}{-7} = -9.$$

Example 19: Solve the equation $\frac{5x+2}{2x+3} = \frac{12}{7}$ —————(1)

Solution: Let us multiply both sides of the given equation by $2x+3$. This gives

$$\frac{5x+2}{2x+3} \times (2x+3) = \frac{12}{7} \times (2x+3)$$

$$5x+2 = \frac{12}{7} \times (2x+3)$$

Again multiply both sides of the equation by 7. This gives

$$7 \times (5x+2) = 7 \times \frac{12}{7} \times (2x+3)$$

$$\Rightarrow 7 \times (5x + 2) = 12 \times (2x + 3) \quad \text{—————(2)}$$

$$35x + 14 = 24x + 36$$

$$35x - 24x = 36 - 14$$

$$11x = 22$$

$$\therefore x = \frac{22}{11} = 2$$

Now look at the given equation i.e., (1) and equation (2) carefully.

Given equation

$$\frac{5x+2}{2x+3} = \frac{12}{7}$$

Simplified form of the given equation

$$7 \times (5x + 2) = 12 \times (2x + 3)$$

What did you notice? All we have done is :

1. Multiply the numerator of the LHS by the denominator of the RHS

$$\frac{5x+3}{2x+3} = \frac{12}{7}$$

2. Multiply the numerator of the RHS by the denominator of the LHS.

$$\frac{5x+3}{2x+3} = \frac{12}{7}$$

3. Equate the expressions obtained in (1) and (2)

$$7 \times (5x + 2) = 12 \times (2x + 3)$$

For obvious reasons, we call this method of solution as the “method of cross multiplication”. Let us now illustrate the method of cross multiplication by examples.

Example 20: Solve the equation $\frac{x+7}{3x+16} = \frac{4}{7}$

Solution: By cross multiplication, we get

$$7 \times (x + 7) = 4 \times (3x + 16)$$

$$7x + 49 = 12x + 64$$

$$7x - 12x = 64 - 49$$

$$-5x = 15$$

$$x = -3$$

$$\frac{x+7}{3x+16} = \frac{4}{7}$$

Example 21: Rehana got 24% discount on her frock. She paid ₹ 380 after discount. Find the marked price of the frock.

Solution: Let the marked price of the frock be ₹ x , then the discount is 24% of x
She paid $x - 24\%$ of x i.e. 380

$$x - 24\% \text{ of } x = 380$$

$$\Rightarrow x - \frac{24}{100} \times x = 380$$

$$\Rightarrow \frac{100x - 24x}{100} = 380$$

$$\Rightarrow \frac{76x}{100} = 380$$

$$x = \frac{380 \times 100}{76}$$

$$\therefore x = 500$$

$$\therefore \text{Marked price} = ₹ 500$$



Example 22: Four fifths of a number is greater than three fourths of the number by 4. Find the number.

Solution: Let the required number be ' x ',

$$\text{then four fifths of the number} = \frac{4}{5}x$$

$$\text{And three fourths of the number} = \frac{3}{4}x$$

It is given that $\frac{4}{5}x$ is greater than $\frac{3}{4}x$ by 4

$$\Rightarrow \frac{4}{5}x - \frac{3}{4}x = 4$$

$$\frac{16x - 15x}{20} = 4$$

$$\Rightarrow \frac{x}{20} = 4 \Rightarrow x = 80$$

Hence the required number is 80.

Example 23: John sold his watch for ₹ 301 and lost 14% on it. Find the cost price of the watch.

Solution: Let the cost price of the watch = ₹ x

$$\text{The loss on it} = 14\% \text{ of 'x'} = \frac{14}{100} \times x = \frac{14x}{100}$$

Selling price of the watch = Cost price – Loss

$$\Rightarrow 301 = x - \frac{14x}{100}$$

$$301 = \frac{100x - 14x}{100}$$

$$301 = \frac{86x}{100}$$

$$\frac{301 \times 100}{86} = x$$

$$350 = x$$

Therefore the cost price of the watch = ₹ 350.

Example 24: A man had to walk a certain distance. He covered two thirds of it at 4kmph and the remaining at 5 kmph. If the total time taken is 42 minutes, find the total distance.

Solution: Let the distance be ' x ' km.



	First part	Second part
Distance covered	$\frac{2}{3}$ of ' x ' = $\frac{2x}{3}$	Remaining distance = $x - \frac{2x}{3} = \frac{x}{3}$
Speed	4 kmph	5 kmph
Time taken	$\frac{\frac{2}{3}x}{4} = \frac{2x}{12}$ hr.	$\frac{\frac{x}{3}}{5} = \frac{x}{15}$ hr.

$$\text{Therefore total time taken} = \frac{2x}{12} + \frac{x}{15} \text{ hr.}$$

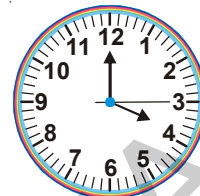

$$\Rightarrow \left(\frac{2x}{12} + \frac{x}{15}\right) \text{ hr} = 42 \text{ min.}$$

$$\Rightarrow \left(\frac{2x}{12} + \frac{x}{15}\right) \text{ hr} = \frac{42}{60} \text{ hr.}$$

$$\frac{2x}{12} + \frac{x}{15} = \frac{42}{60}$$

$$\frac{10x + 4x}{60} = \frac{42}{60}$$

$$\Rightarrow 14x = 42$$

$$\Rightarrow x = 3$$

Total distance $x = 3$ km.

Example 25: The numerator of a fraction is 6 less than the denominator. If 3 is added to the numerator, the fraction is equal to $\frac{2}{3}$, find the original fraction

Solution: Let the denominator of the fraction be 'x' then

Numerator of the fraction = $x - 6$

Therefore the fraction = $\frac{x-6}{x}$

If 3 is added to the numerator, it becomes $\frac{2}{3}$

$$\Rightarrow \frac{x-6+3}{x} = \frac{2}{3}$$

$$\frac{x-3}{x} = \frac{2}{3}$$

$$\Rightarrow 3x - 9 = 2x$$

$$x = 9$$

$$\therefore \text{Fraction} = \frac{x-6}{x} = \frac{9-6}{9} = \frac{3}{9}$$

Therefore required fraction is $\frac{3}{9}$.

Example 26: Sirisha has ₹ 9 in fifty-paise and twenty five paise coins. She has twice as many twenty five paise coins as she has fifty paise coins. How many coins of each kind does she have?



Solution: Let the number of fifty paise coins = x

Therefore the number of twenty five paise coins = $2x$.

$$\text{Value of fifty paise coins} = x \times 50 \text{ paise} = ₹ \frac{50x}{100} = ₹ \frac{x}{2}$$

$$\begin{aligned} \text{Value of twenty five paise coins} &= 2x \times 25 \text{ paise} = 2x \times \frac{25}{100} \\ &= 2x \times \frac{1}{4} = ₹ \frac{x}{2} \end{aligned}$$

$$\text{Total value of all coins} = ₹ \left(\frac{x}{2} + \frac{x}{2} \right)$$

But the total value of money is ₹ 9

$$\Rightarrow \frac{x}{2} + \frac{x}{2} = 9$$

$$\frac{2x}{2} = 9$$

$$\therefore x = 9$$

Therefore number of fifty paise coins = $x = 9$

Number of twenty paise coins = $2x = 2 \times 9 = 18$.

Example 27: A man driving his moped at 24 kmph reaches his destination 5 minutes late to an appointment. If he had driven at 30 kmph he would have reached his destination 4 minutes before time. How far is his destination?

Solution: Let the distance be ' x ' km.

Therefore time taken to cover ' x ' km. at 24 kmph = $\frac{x}{24}$ hr.

Time taken to cover ' x ' km. at 30 kmph = $\frac{x}{30}$ hr.

But it is given that the difference between two timings = $9 \text{ min} = \frac{9}{60} \text{ hr}$.

$$\therefore \frac{x}{24} - \frac{x}{30} = \frac{9}{60}$$

$$\therefore \frac{5x - 4x}{120} = \frac{9}{60}$$

$$\Rightarrow \frac{x}{120} = \frac{9}{60}$$

$$\Rightarrow x = \frac{9}{60} \times 120 = 18$$

Therefore the distance is 18 km.



Exercise - 2.5

1. Solve the following equations.

(i) $\frac{n}{5} - \frac{5}{7} = \frac{2}{3}$

(ii) $\frac{x}{3} - \frac{x}{4} = 14$

(iii) $\frac{z}{2} + \frac{z}{3} - \frac{z}{6} = 8$

(iv) $\frac{2p}{3} - \frac{p}{5} = 11\frac{2}{3}$

(v) $9\frac{1}{4} = y - 1\frac{1}{3}$

(vi) $\frac{x}{2} - \frac{4}{5} + \frac{x}{5} + \frac{3x}{10} = \frac{1}{5}$

(vii) $\frac{x}{2} - \frac{1}{4} = \frac{x}{3} + \frac{1}{2}$

(viii) $\frac{2x-3}{3x+2} = \frac{-2}{3}$

(ix) $\frac{8p-5}{7p+1} = \frac{-2}{4}$

(x) $\frac{7y+2}{5} = \frac{6y-5}{11}$

(xi) $\frac{x+5}{6} - \frac{x+1}{9} = \frac{x+3}{4}$

(xii) $\frac{3t+1}{16} - \frac{2t-3}{7} = \frac{t+3}{8} + \frac{3t-1}{14}$

2. What number is that of which the third part exceeds the fifth part by 4?

3. The difference between two positive integers is 36. The quotient when one integer is divided by other is 4. Find the integers.

(Hint: If one number is 'x', then the other number is 'x - 36')

4. The numerator of a fraction is 4 less than the denominator. If 1 is added to both its numerator and denominator, it becomes $\frac{1}{2}$. Find the fraction.

5. Find three consecutive numbers such that if they are divided by 10, 17, and 26 respectively, the sum of their quotients will be 10.

(Hint: Let the consecutive numbers = $x, x + 1, x + 2$, then $\frac{x}{10} + \frac{x+1}{17} + \frac{x+2}{26} = 10$)

6. In class of 40 pupils the number of girls is three-fifths of the number of boys. Find the number of boys in the class.

7. After 15 years, Mary's age will be four times of her present age. Find her present age.

8. Aravind has a kiddy bank. It is full of one-rupee and fifty paise coins. It contains 3 times as many fifty paise coins as one rupee coins. The total amount of the money in the bank is ₹ 35. How many coins of each kind are there in the bank?

9. A and B together can finish a piece of work in 12 days. If 'A' alone can finish the same work in 20 days, in how many days B alone can finish it?

10. If a train runs at 40 kmph it reaches its destination late by 11 minutes. But if it runs at 50 kmph it is late by 5 minutes only. Find the distance to be covered by the train.

11. One fourth of a herd of deer has gone to the forest. One third of the total number is grazing in a field and remaining 15 are drinking water on the bank of a river. Find the total number of deer.

12. By selling a radio for ₹903, a shop keeper gains 5%. Find the cost price of the radio.

13. Sekhar gives a quarter of his sweets to Renu and then gives 5 sweets to Raji. He has 7 sweets left. How many did he have to start with?



What we have discussed

1. If the degree of an equation is one then it is called a linear equation.
2. If a linear equation has only one variable then it is called a linear equation in one variable or simple equation.
3. The value which when substituted for the variable in the given equation makes L.H.S. = R.H.S. is called a solution or root of the given equation.
4. Just as numbers, variables can also be transposed from one side of the equation to the other side.



A magic Diamond

Find numbers to put in the circles so that the total along each line of the diamond is the same.

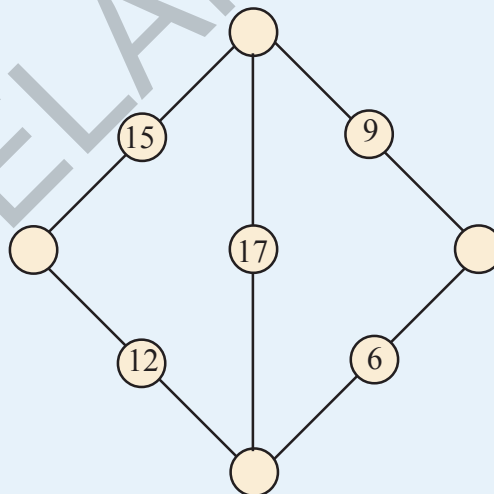
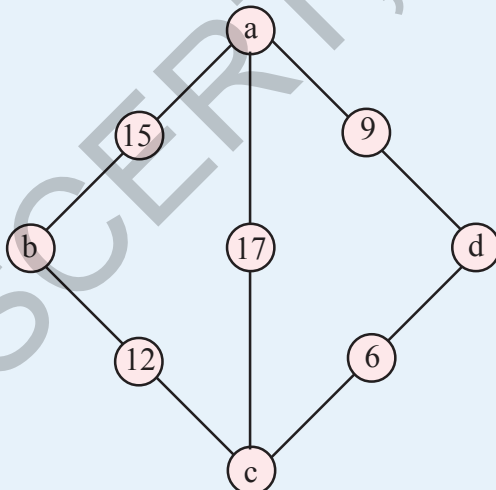

Hint : The number will be of the form
 $a = x, b = 5 + x, c = 3 + x, d = 11 + x$

Where x is any number and the total along each line will be $20 + 2x$.

For example if $x = 1$, then $a = 1, b = 6, c = 4, d = 12$ and each line total will be 22.



3.0 Introduction

We see fields, houses, bridges, railway tracks, school buildings, play grounds etc, around us. We also see kites, ludos, carrom boards, windows, blackboards and other things around. When we draw these things what do the figures look like? What is the basic geometrical shape in all these? Most of these are quadrilateral figures with four sides.



Kamal and Joseph are drawing a figure to make a frame of measurement with length 8 cm and breadth 6 cm. They drew their figures individually without looking at each other's figure.

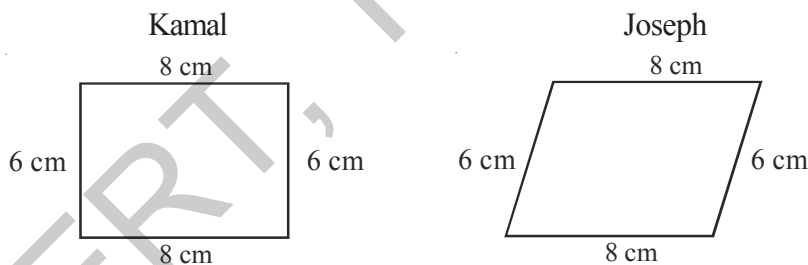

Are both the figures same?

You can see that both of these figures are quadrilaterals with the same measurements but the figures are not same. In class VII we have discussed about uniqueness of triangles. To construct unique triangle you need three sides or two sides and one included angle or two angles and a side. How many measurements do we need to construct a unique quadrilateral? By a unique quadrilateral we mean that quadrilaterals made by different persons with the same measurements will be congruent.



Do This

Take a pair of sticks of equal length, say 8 cm. Take another pair of sticks of equal length, say, 6 cm. Arrange them suitably to get a rectangle of length 8 cm and breadth 6 cm. This rectangle is created with the 4 available measurements. Now just push along the breadth of the rectangle. Does it still look alike? You will get a new shape of a rectangle Fig (ii), observe that the rectangle has now become a parallelogram. Have you altered the lengths of the sticks? No! The measurements of sides remain the same. Give another push to the newly obtained shape in the opposite direction; what do you get? You again get a parallelogram again, which is altogether different Fig (iii). Yet the four measurements remain the same. This shows that 4 measurements of a quadrilateral cannot determine its uniqueness. So, how many measurements determine a unique quadrilateral? Let us go back to the activity!

You have constructed a rectangle with two sticks each of length 8 cm and other two sticks each of length 6 cm. Now introduce another stick of length equal to BD and put it along BD (Fig iv). If you push the breadth now, does the shape change? No! It cannot, without making the figure open. The introduction of the fifth stick has fixed the rectangle uniquely, i.e., there is no other quadrilateral (with the given lengths of sides) possible now. Thus, we observe that five measurements can determine a quadrilateral uniquely. But will any five measurements (of sides and angles) be sufficient to draw a unique quadrilateral?

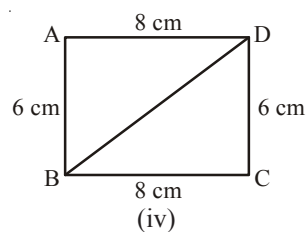
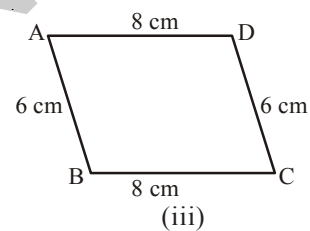
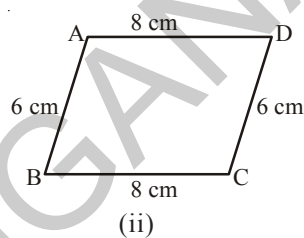
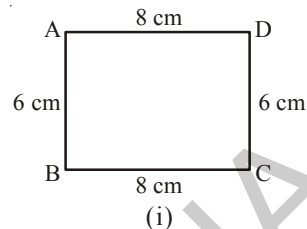

3.1 Quadrilaterals and their Properties

In the given Figure, $ABCD$ is a quadrilateral with vertices A, B, C, D and sides ; $\overline{AB}, \overline{BC}, \overline{CD}, \overline{DA}$. The angles of $ABCD$ are $\angle BAD, \angle ADC, \angle DCB$ and $\angle CBD$ and the diagonals are $\overline{AC}, \overline{BD}$.

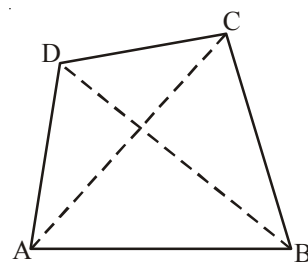



Do This

Equipment

You need: a ruler, a set square, a protractor.

Remember:

To check if the given lines are parallel, slide the set square from the first line to the second line as shown in adjacent figures.



Now let us investigate the following using proper instrument

For each quadrilateral.

- Check if opposite sides are parallel.
- Measure each angle.
- Measure the length of each side.

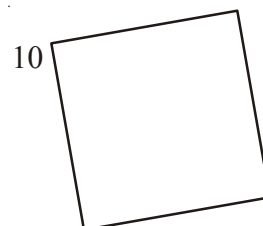
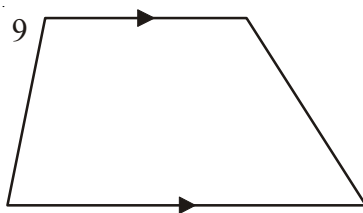
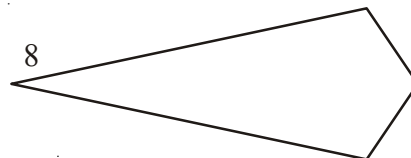
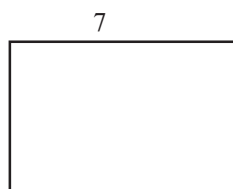
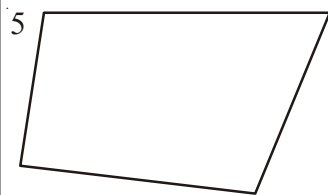
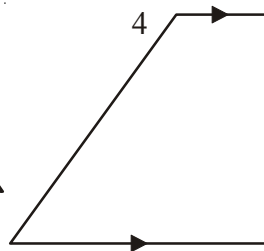
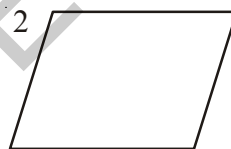
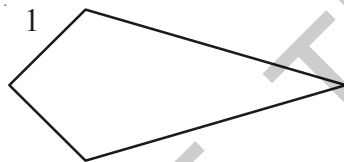

Record your observations and complete the table given below.

Quadrilateral	2 pairs of parallel sides	1 pair of parallel sides	4 right angles	2 pairs of opposite sides equal	2 pairs of opposite angles equal	2 pairs of adjacent sides equal	4 sides equal
1	x	x	x	x	x	✓	x
2							
3							
4							
5							
6							
7							
8							
9							
10							

Parallelogram is a quadrilateral with 2 pairs of parallel sides.

- Which shapes are parallelograms?
- What are the other properties does a parallelogram have?

Rectangle is a parallelogram with four right angles.

- Which shapes are rectangles?
- What properties does a rectangle have?

Rhombus is a parallelogram with four equal sides.

- Which could be called a rhombus?
- What properties does a rhombus have?

Square is a rhombus with four right angles.

- Which shapes are squares?
- What properties does a square have?

Trapezium is a quadrilateral with at least one pair of parallel sides.

- Which of the shapes could be called only a trapezium?
- What are the properties of a trapezium?

Quadrilaterals 1 and 8 are **kites**. Write down some properties of kites.
 We can classify quadrilaterals based on the properties you have observed.

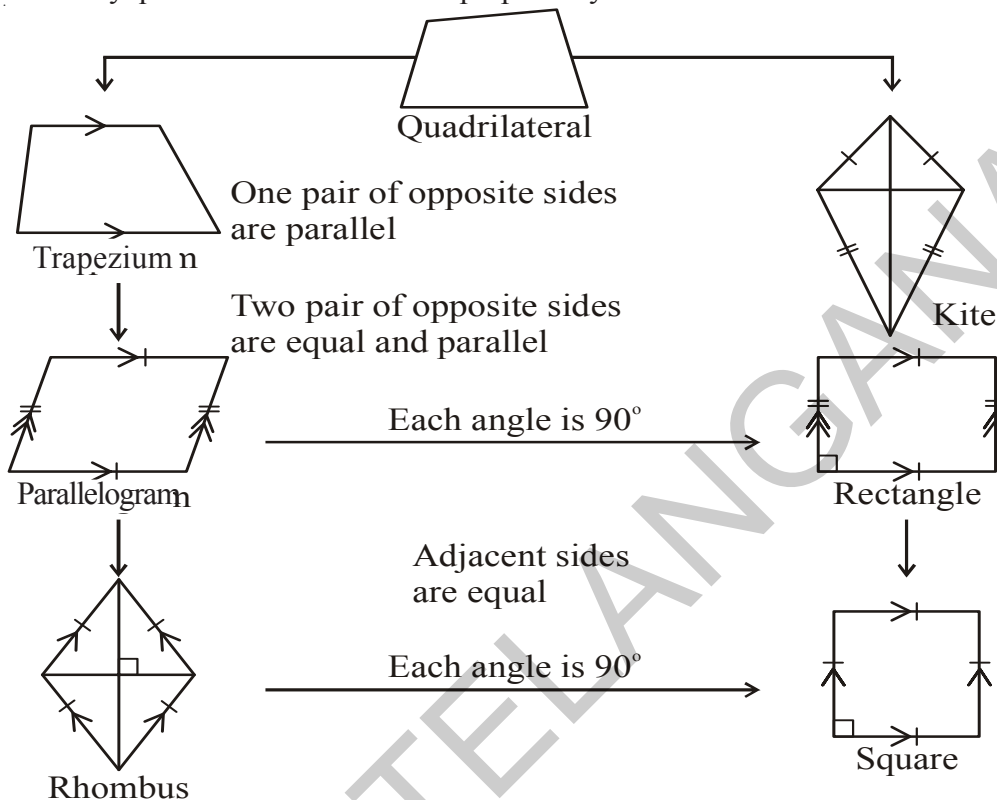

Think, Discuss and Write

1. Is every rectangle a parallelogram? Is every parallelogram a rectangle?
2. Uma has made a sweet chikki. She wanted it to be rectangular shaped. In how many different ways can she verify that it is rectangular?



Do This

Can you draw the angle of 60°



Compass

Allowed

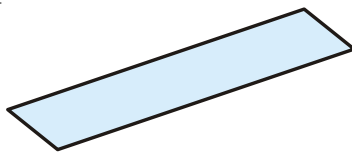

A straight edge Scale (Ruler)

Not allowed

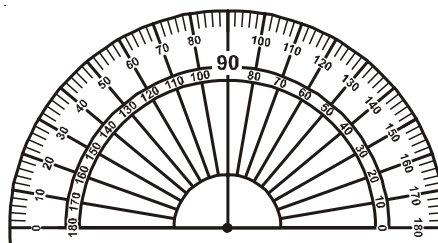

Protractor

Observe the illustrations and write steps of construction for each.

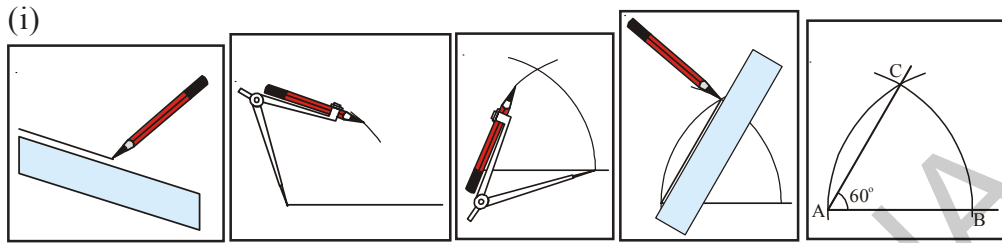

(a) (b) (c) (d) (e)

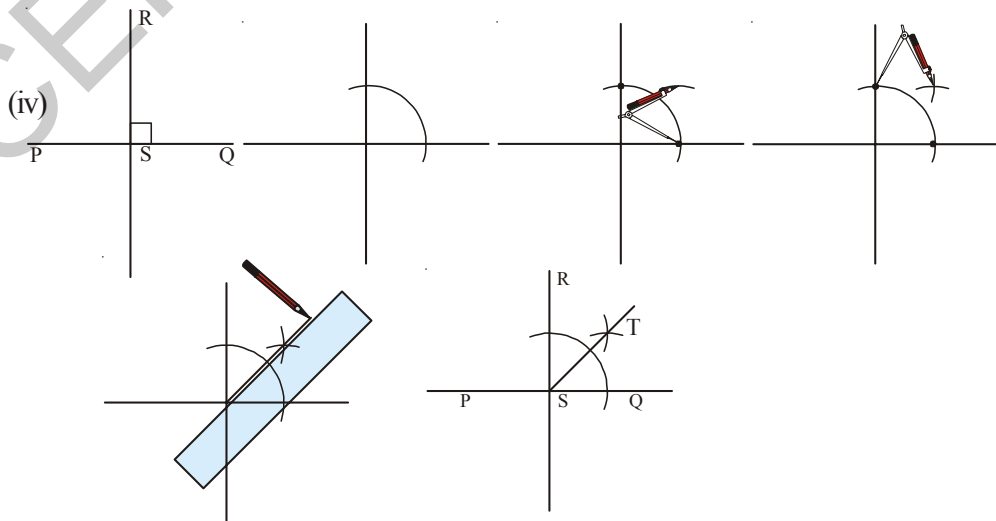
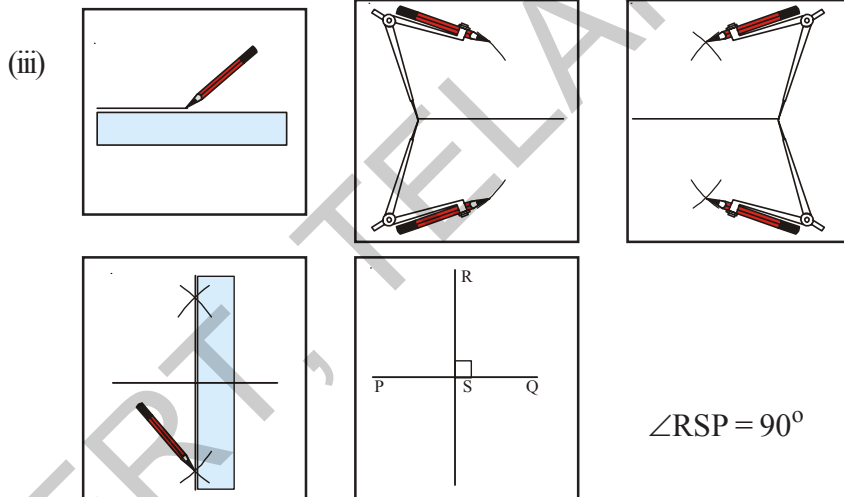
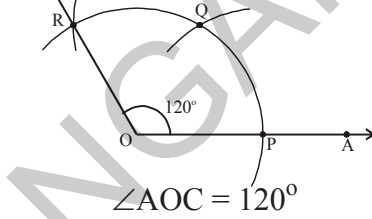
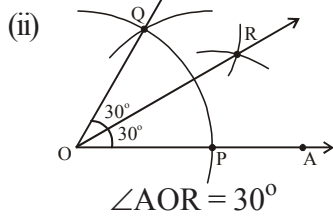

3.2 Constructing a Quadrilateral

We would draw quadrilaterals when the following measurements are given.

1. When four sides and one angle are given (S.S.S.S.A)
2. When four sides and one diagonal are given (S.S.S.S.D)
3. When three sides and two diagonals are given (S.S.S.D.D)
4. When two adjacent sides and three angles are given (S.A.S.A.A)
5. When three sides and two included angles are given (S.A.S.A.S)

3.2.1 Construction : When the lengths of four sides and one angle are given (S.S.S.S.A)

Example 1 : Construct a quadrilateral PQRS in which $PQ = 4.5$ cm, $QR = 5.2$ cm, $RS = 5.5$ cm, $PS = 4$ cm and $\angle RQP = 120^\circ$.

Solution :

Step 1 : Draw a rough sketch of the required quadrilateral and mark the given measurements. Are they enough ?

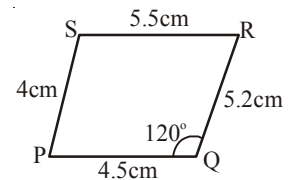

Step 2 : Draw $\triangle PQR$ using S.A.S Property of construction, by taking $PQ = 4.5$ cm, $\angle RQP = 120^\circ$ and $QR = 5.2$ cm.

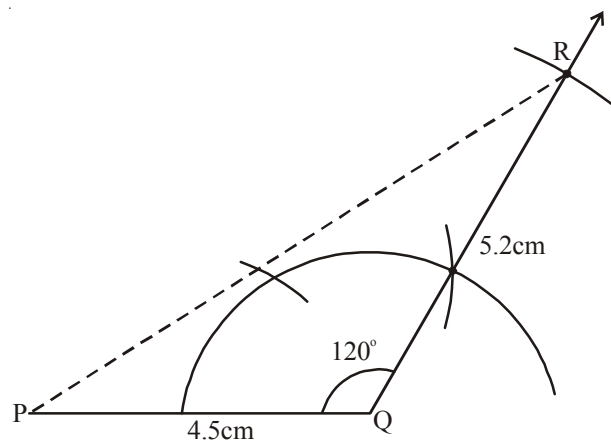

Step 3 : To locate the fourth vertex 'S', draw an arc, with centre P and radius 4cm ($PS = 4$ cm) Draw another arc with centre R and radius 5.5 cm ($RS = 5.5$ cm) which cuts the previous arc at S.

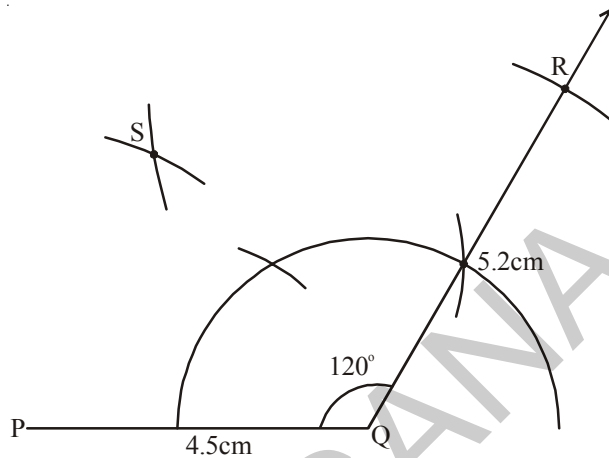

Step 4 : Join PS and RS to complete the required quadrilateral PQRS.

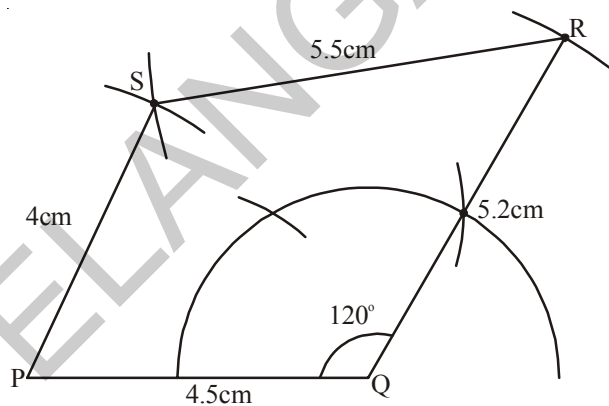

Example 2 : Construct parallelogram ABCD given that $AB = 5$ cm, $BC = 3.5$ cm and $\angle A = 60^\circ$.

Solution :

Step 1 : Draw a rough sketch of the parallelogram (a special type of quadrilateral) and mark the given measurements.

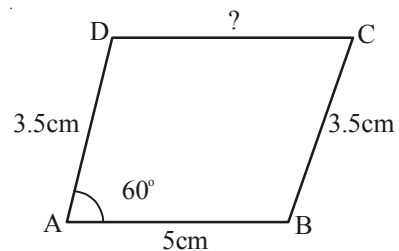

Here we are given only 3 measurements. But as the ABCD is a parallelogram we can also write that $CD = AB = 5$ cm and $AD = BC = 3.5$ cm. (How?)

(Now we got 5 measurements in total).

Steps 2: Draw $\triangle BAD$ using the measures $AB=5$ cm, $\angle A=60^\circ$ and $AD=3.5$ cm.

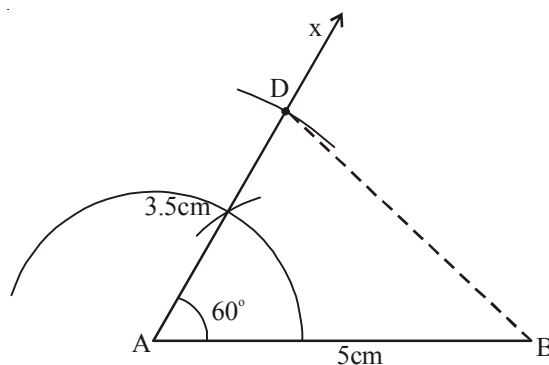

Steps 3: Locate the fourth vertex 'C' using other two measurements $BC=3.5\text{cm}$ and $DC = 5\text{cm}$.

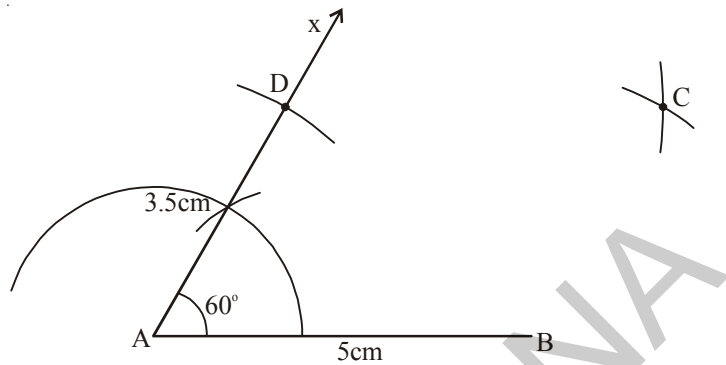

Step 4 : Join B, C and C, D to complete the required parallelogram ABCD.

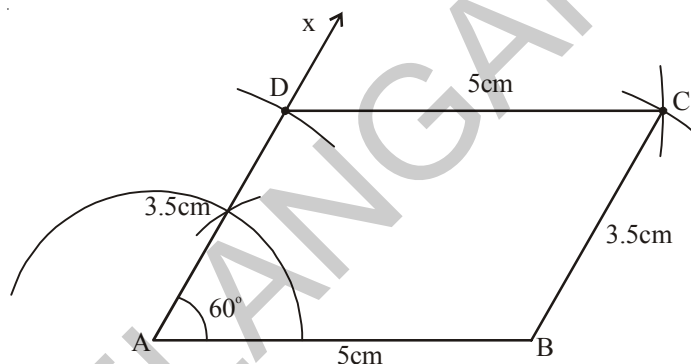

(Verify the property of the parallelogram using scale and protractor)

Let us generalize the steps of construction of quadrilateral.

Step 1: Draw a rough sketch of the figure .

Step 2 : If the given measurements are insufficient, analyse the figure. Try to use special properties of the figure to obtain the required measurements

Step 3 : Draw a triangle with three of the five measurements and use the other measurements to locate the fourth vertex.

Step 4: Describe the steps of construction in detail.



Exercise - 3.1

Construct the quadrilaterals with the given measurements. And write steps of construction.

- Quadrilateral ABCD with $AB = 5.5\text{ cm}$, $BC = 3.5\text{ cm}$, $CD = 4\text{ cm}$, $AD = 5\text{ cm}$ and $\angle A = 45^\circ$.
- Quadrilateral BEST with $BE = 2.9\text{ cm}$, $ES = 3.2\text{ cm}$, $ST = 2.7\text{ cm}$, $BT = 3.4\text{ cm}$ and $\angle B = 75^\circ$.
- Parallelogram PQRS with $PQ = 4.5\text{ cm}$, $QR = 3\text{ cm}$ and $\angle RQP = 60^\circ$.

- (d) Rhombus MATH with $AT = 4 \text{ cm}$, $\angle MAT = 120^\circ$.
- (e) Rectangle FLAT with $FL = 5 \text{ cm}$, $LA = 3 \text{ cm}$.
- (f) Square LUDO with $LU = 4.5 \text{ cm}$.

3.2.2 Construction : When the lengths of four sides and a diagonal is given (S.S.S.S.D)

Example 3: Construct a quadrilateral ABCD where $AB = 4 \text{ cm}$, $BC = 3.6 \text{ cm}$, $CD = 4.2 \text{ cm}$, $AD = 4.8 \text{ cm}$ and $AC = 5 \text{ cm}$.

Solution :

Step 1: Draw a rough sketch of the quadrilateral ABCD with the given data.

(Analyse if the given data is sufficient to draw the quadrilateral or not.

If sufficient then proceed further, if not conclude that the data is not enough to draw the given figure).

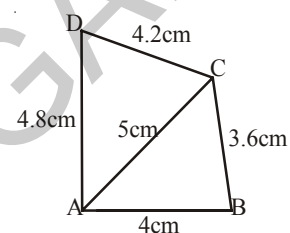

Step 2: Construct $\triangle ABC$ with $AB = 4 \text{ cm}$, $BC = 3.6 \text{ cm}$ and $AC = 5 \text{ cm}$

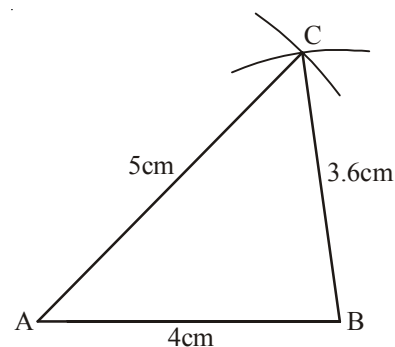

Step 3: We have to locate the fourth vertex 'D'. It would be on the other side of AC. So with centre A and radius 4.8 cm ($AD = 4.8 \text{ cm}$) draw an arc and with centre C and radius 4.2 cm ($CD = 4.2 \text{ cm}$) draw another arc to cut the previous arc at D.

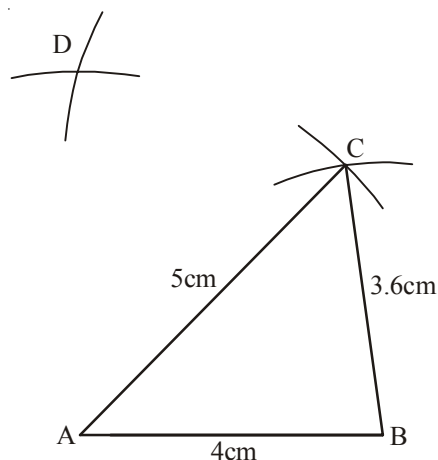

Step 4: Join A, D and C, D to complete the quadrilateral ABCD.

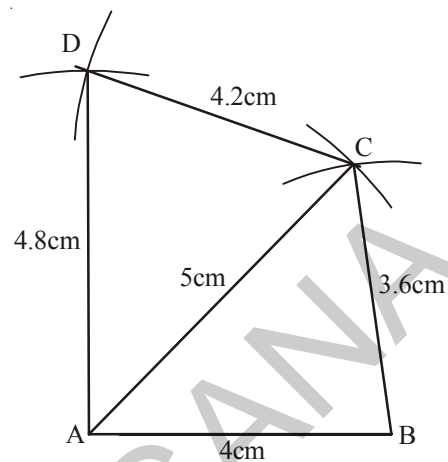

Example 4: Construct a rhombus BEST with $BE = 4.5$ cm and $ET = 5$ cm

Solution :

Step 1 : Draw a rough sketch of the rhombus (a special type of quadrilateral). In which all sides are equal. So $BE = ES = ST = BT = 4.5$ cm and mark the given measurements.

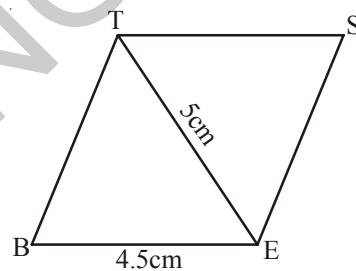

Now, with these measurements, we can construct the figure.

Step 2 : Draw $\triangle BET$ using SSS property of construction with measures $BE = 4.5$ cm, $ET = 5$ cm and $BT = 4.5$ cm

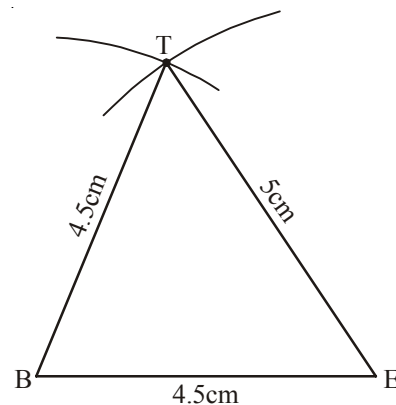

Step 3 : By drawing the arcs locate the fourth vertex 'S', with the remaining two measures $ES = 4.5$ cm and $ST = 4.5$ cm.

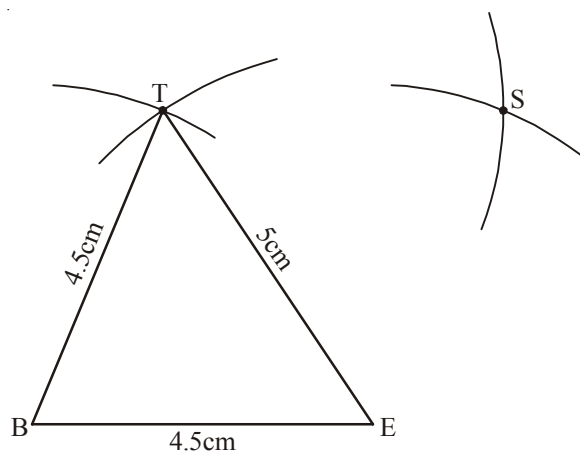

Step 4 : Join E, S and S, T to complete the required rhombus BEST.

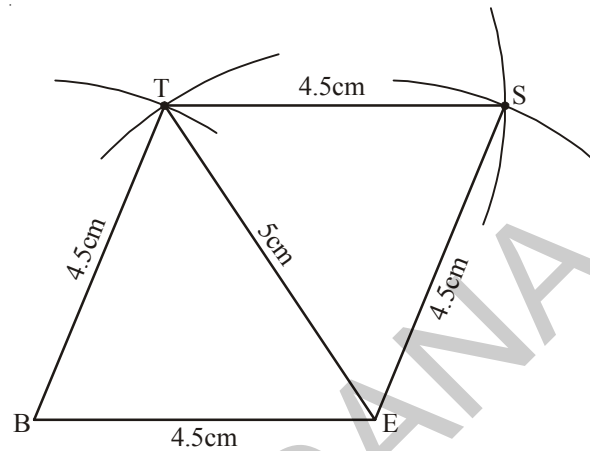

Try These

1. Can you draw a parallelogram BATS where $BA = 5$ cm, $AT = 6$ cm and $AS = 6.5$ cm? explain?
2. A student attempted to draw a quadrilateral PLAY given that $PL = 3$ cm, $LA = 4$ cm, $AY = 4.5$ cm, $PY = 2$ cm and $LY = 6$ cm. But he was unable to draw it why? Try to draw the quadrilateral yourself and give reason.



Exercise - 3.2

Construct quadrilateral with the measurements given below :

- (a) Quadrilateral ABCD with $AB = 4.5$ cm, $BC = 5.5$ cm, $CD = 4$ cm, $AD = 6$ cm and $AC = 7$ cm
- (b) Quadrilateral PQRS with $PQ = 3.5$ cm, $QR = 4$ cm, $RS = 5$ cm, $PS = 4.5$ cm and $QS = 6.5$ cm
- (c) Parallelogram ABCD with $AB = 6$ cm, $AD = 4.5$ cm and $BD = 7.5$ cm
- (d) Rhombus NICE with $NI = 4$ cm and $IE = 5.6$ cm

3.2.3 Construction: When the lengths of three sides and two diagonals are given (S.S.S.D.D)

Example 5 : Construct a quadrilateral ABCD, given that $AB = 4.5$ cm, $BC = 5.2$ cm, $CD = 4.8$ cm and diagonals $AC = 5$ cm and $BD = 5.4$ cm.

Solution:

Step 1: We first draw a rough sketch of the quadrilateral ABCD.
Mark the given measurements.

(It is possible to draw $\triangle ABC$ with the available measurements)

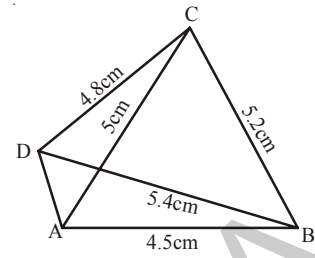

Step 2: Draw $\triangle ABC$ using SSS Property of construction with measures $AB = 4.5$ cm, $BC = 5.2$ cm and $AC = 5$ cm

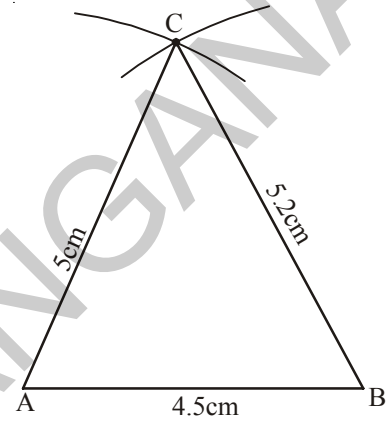

Step 3: With centre B and radius 5.4 cm and with centre C and radius 4.8 cm draw two arcs opposite to vertex B to locate D.

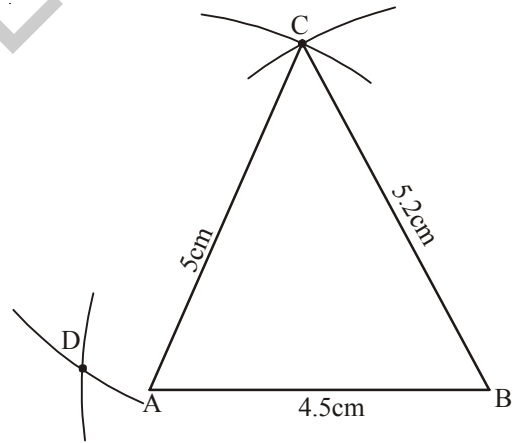

Step 4: Join C,D, B,D and A,D to complete the quadrilateral ABCD.

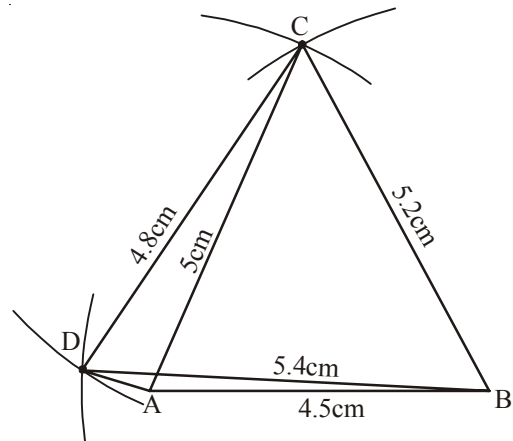



Think, Discuss and Write

1. Can you draw the quadrilateral ABCD (given above) by constructing $\triangle ABD$ first and then fourth vertex 'C'? Give reason.
2. Construct a quadrilateral PQRS with $PQ = 3$ cm, $RS = 3$ cm, $PS = 7.5$ cm, $PR = 8$ cm and $SQ = 4$ cm. Justify your result.



Exercise - 3.3

Construct the quadrilateral with the measurements given below.

- (a) Quadrilateral GOLD; $OL = 7.5$ cm, $GL = 6$ cm, $LD = 5$ cm, $DG = 5.5$ cm and $OD = 10$ cm
- (b) Quadrilateral PQRS $PQ = 4.2$ cm, $QR = 3$ cm, $PS = 2.8$ cm, $PR = 4.5$ cm and $QS = 5$ cm.

3.2.4 Construction : When the lengths of two adjacent sides and three angles are known (S.A.S.A.A)

We construct the quadrilateral required as before but as many angles are involved in the construction use a ruler and a compass for standard angles and a protractor for others.

Example 6 : Construct a quadrilateral PQRS, given that $PQ = 4$ cm, $QR = 4.8$ cm, $\angle P = 75^\circ$, $\angle Q = 100^\circ$ and $\angle R = 120^\circ$.

The angles such as 0° , 30° , 45° , 60° , 90° , 120° and 180° are called standard angles.

Solution :

Step 1 : We draw a rough sketch of the quadrilateral and mark the given measurements. Select the proper instruments to construct angles.

Step 2: Construct $\triangle PQR$ using SAS property of construction with measures $PQ = 4$ cm, $\angle Q = 100^\circ$ and $QR = 4.8$ cm
(Why a dotted line is used to join PR? This can be avoided in the next step).

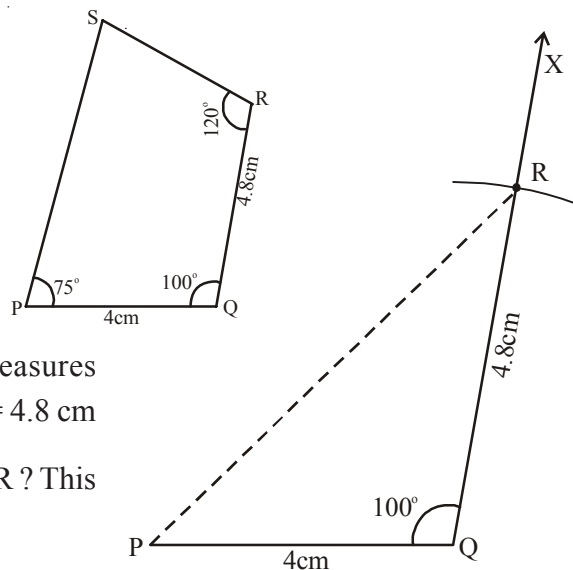

Step 3: Construct $\angle P = 75^\circ$ and draw \overline{PY}

[Do you understand how 75° is constructed?]

(a) An arc is drawn from P. Let it intersect PQ at P'. With center P' and with the same radius draw two arcs to cut at two points A, B which give 60° and 120° respectively.

(b) From A, B construct an angular bisector. Which cuts the arc at C, making 90° .

(c) From A, C construct angular bisector (median of 60° and 90°) which is 75° .]

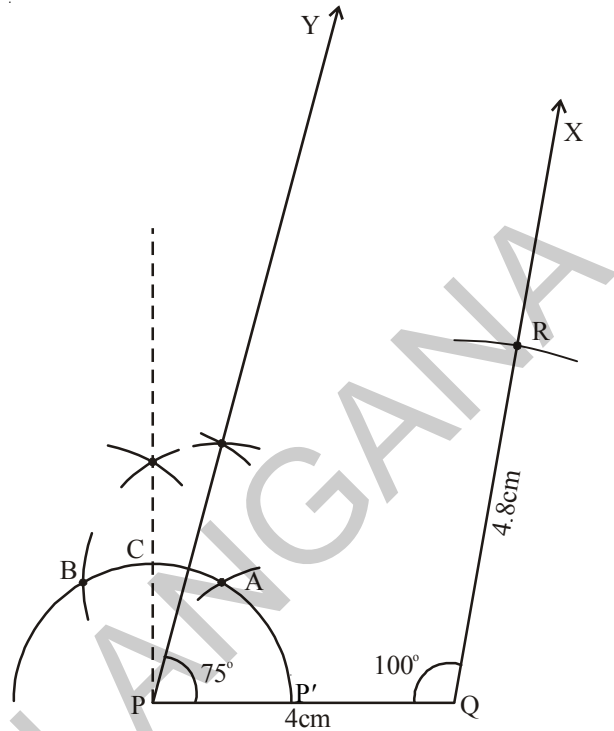

Step 4: Construct $\angle R = 120^\circ$ and draw \overline{RZ} to meet \overline{PY} at S.

PQRS is the required quadrilateral.

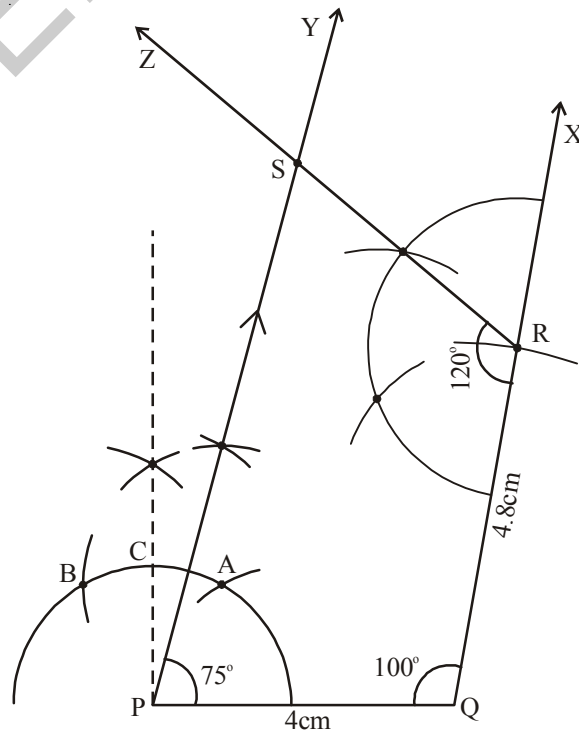



Think, Discuss and Write

1. Can you construct the above quadrilateral PQRS, if we have an angle of 100° at P instead of 75° . Give reason.
2. Can you construct the quadrilateral PLAN if $PL = 6$ cm, $LA = 9.5$ cm, $\angle P = 75^\circ$, $\angle L = 15^\circ$ and $\angle A = 140^\circ$.

(Draw a rough sketch in each case and analyse the figure) State the reasons for your conclusion.

Example 7 : Construct a parallelogram BELT, given that $BE = 4.2$ cm, $EL = 5$ cm, $\angle T = 45^\circ$.

Solution :

Step 1 : Draw a rough sketch of the parallelogram BELT and mark the given measurements. (Are they sufficient for construction ?)

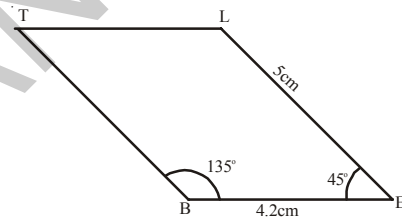

Analysis :

Since the given measures are not sufficient for construction, we shall find the required measurements using the properties of a parallelogram.

As “Opposite angles of a parallelogram are equal” so $\angle E = \angle T = 45^\circ$ and

“The consecutive angles are supplementary” so $\angle L = 180^\circ - 45^\circ = 135^\circ$.

Thus $\angle B = \angle L = 135^\circ$

Step 2 : Construct $\triangle BEL$ using SAS property of construction model with $BE = 4.2$ cm, $\angle E = 45^\circ$ and $EL = 5$ cm

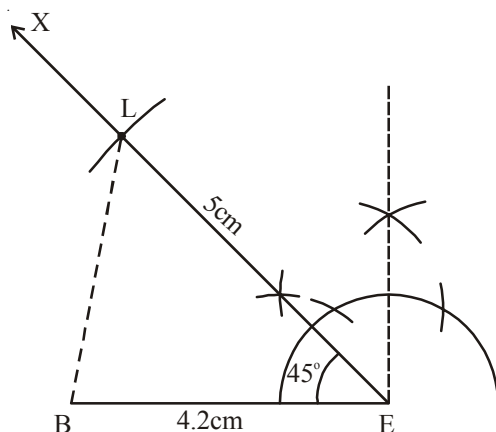

Step 3 : Construct $\angle B = 135^\circ$ and draw \overline{BY}

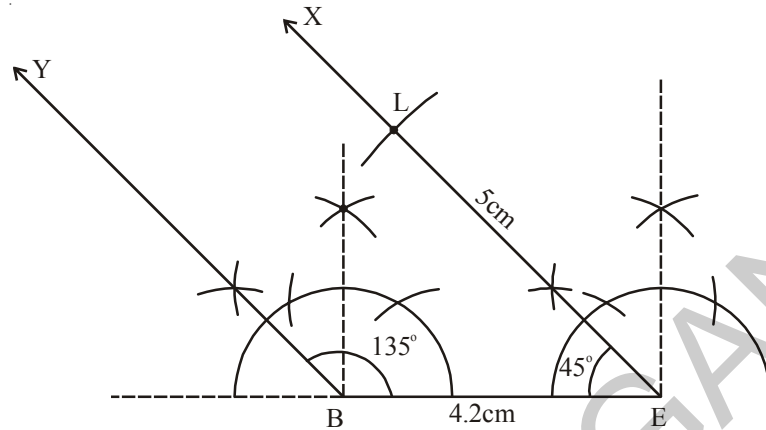

Step 4 : Construct $\angle L = 135^\circ$ and draw \overline{LN} to meet \overline{BY} at T.

BELT is the required quadrilateral (i.e. parallelogram)

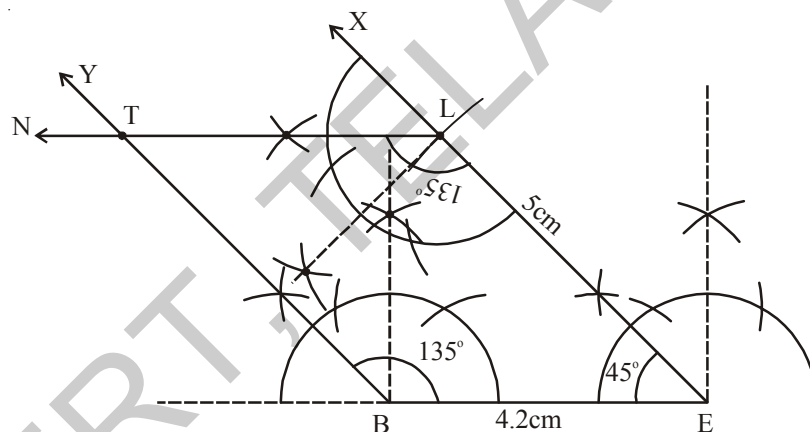

Do This

Construct the above parallelogram BELT by using other properties of parallelogram?



Exercise - 3.4

Construct quadrilaterals with the measurements given below :

- (a) Quadrilateral HELP with $HE = 6\text{cm}$, $EL = 4.5\text{ cm}$, $\angle H = 60^\circ$, $\angle E = 105^\circ$ and $\angle P = 120^\circ$.
- (b) Parallelogram GRAM with $GR = AM = 5\text{ cm}$, $RA = MG = 6.2\text{ cm}$ and $\angle R = 85^\circ$.
- (c) Rectangle FLAG with sides $FL = 6\text{cm}$ and $LA = 4.2\text{ cm}$.

3.2.5 Construction :When the lengths of three sides and two included angles are given (S.A.S.A.S)

We construct this type of quadrilateral by constructing a triangle with SAS property. Note particularly the included angles.

Example 8 : Construct a quadrilateral ABCD in which $AB = 5\text{cm}$, $BC = 4.5\text{cm}$, $CD = 6\text{cm}$, $\angle B = 100^\circ$ and $\angle C = 75^\circ$.

Solution :

Step 1 : Draw a rough sketch, as usual and mark the measurements given (Find whether these measures are sufficient to construct a quadrilateral or not? If yes, proceed)

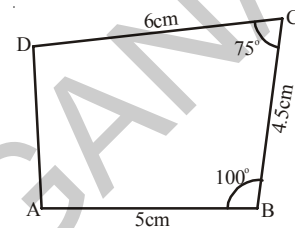

Step 2 : Draw $\triangle ABC$ with measures $AB = 5\text{cm}$, $\angle B = 100^\circ$ and $BC = 4.5\text{cm}$ using SAS rule.

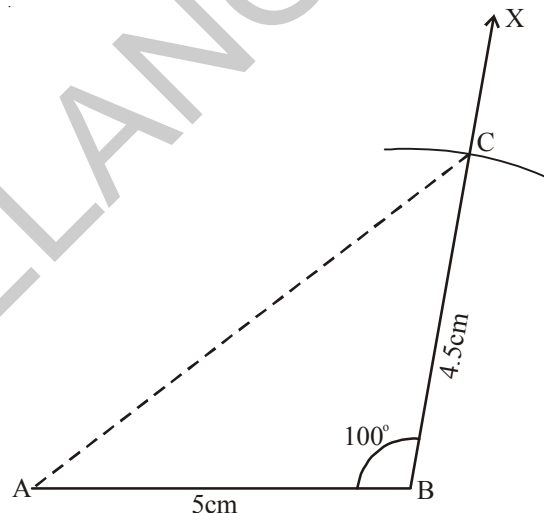

Step 3 : Construct $\angle C = 75^\circ$ and Draw \overline{CY} .

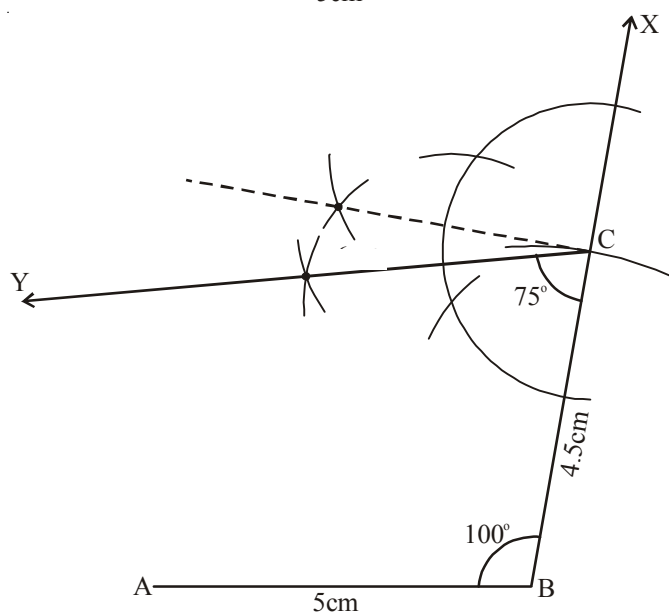

Step 4 : With centre 'C' and radius 6 cm draw an arc to intersect \overline{CY} at D. Join A, D. ABCD is the required quadrilateral.

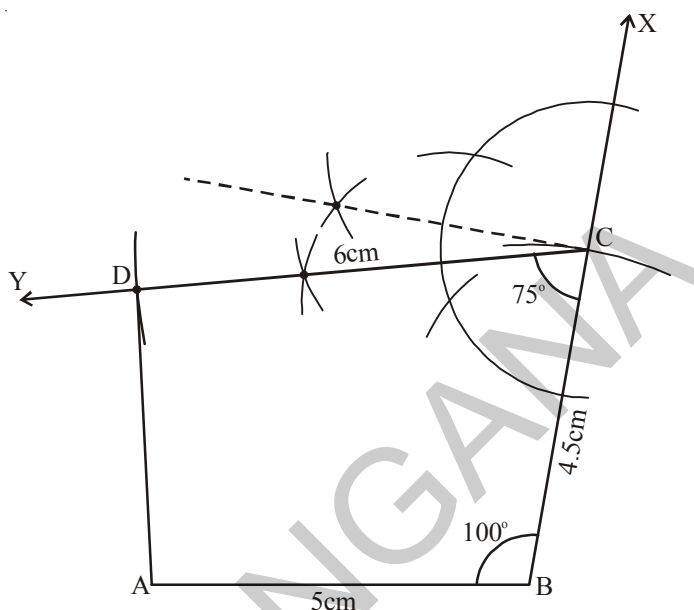

Think, Discuss and Write

Do you construct the above quadrilateral ABCD by taking BC as base instead of AB? If So, draw a rough sketch and explain the various steps involved in the construction.



Exercise - 3.5

Construct following quadrilaterals-

- Quadrilateral PQRS with $PQ = 3.6\text{cm}$, $QR = 4.5\text{cm}$, $RS = 5.6\text{cm}$, $\angle RQP = 135^\circ$ and $\angle SRQ = 60^\circ$.
- Quadrilateral LAMP with $AM = MP = PL = 5\text{cm}$, $\angle M = 90^\circ$ and $\angle P = 60^\circ$.
- Trapezium ABCD in which $AB \parallel CD$, $AB = 8\text{cm}$, $BC = 6\text{cm}$, $CD = 4\text{cm}$ and $\angle B = 60^\circ$.

3.2.6 Construction of Special types Quadrilaterals

(a) Construction of a Rhombus :

Example 9 : Draw a rhombus ABCD in which diagonals $AC = 4.5\text{cm}$ and $BD = 6\text{cm}$.

Solution :

Step 1 : Draw a rough sketch of rhombus ABCD and mark the given measurements. Are these measurements enough to construct the required figure ?

To examine this, we use one or other properties of rhombus to construct it.

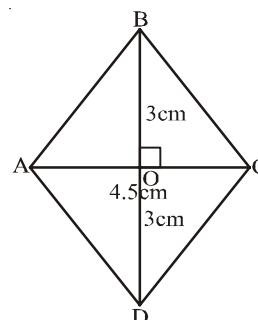

Analysis: The diagonals of a rhombus bisect each other perpendicularly, \overline{AC} and \overline{BD} are diagonals of the rhombus ABCD. Which bisect each other at 'O'. i.e. $\angle AOB = 90^\circ$ and

$$OB = OD = \frac{BD}{2} = \frac{6}{2} = 3 \text{ cm}$$

Now proceed to step 2 for construction.

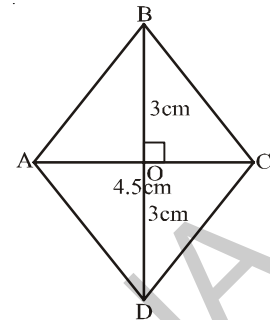

Step 2: Draw $\overline{AC} = 4.5 \text{ cm}$ (one diagonal of the rhombus ABCD) and draw a perpendicular bisector \overline{XY} of it and mark the point of intersection as 'O'.

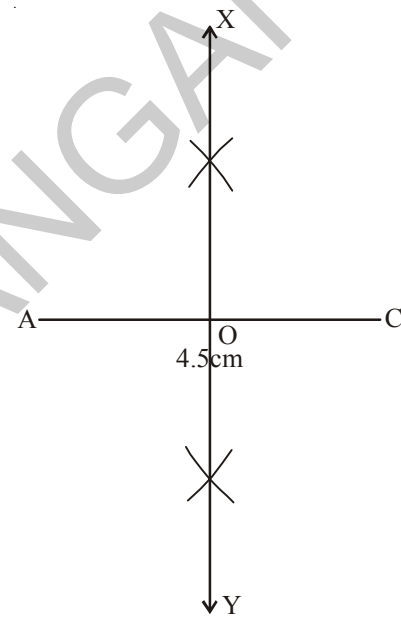

Step 3: As the other diagonal \overline{BD} is Perpendicular to \overline{AC} , \overline{BD} is a part of \overline{XY} . So with centre 'O' and radius 3 cm ($OB = OD = 3 \text{ cm}$) draw two arcs on either sides of \overline{AC} to cut \overline{XY} at B and D.

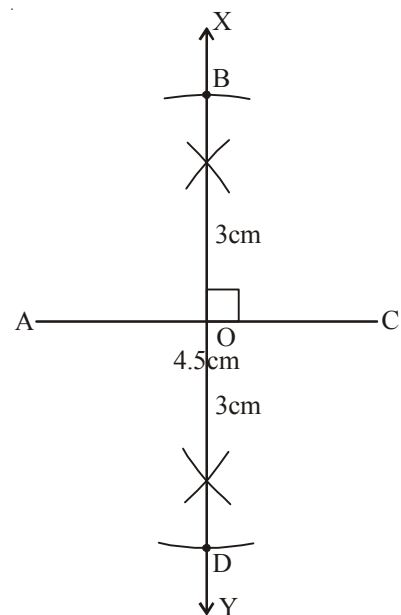

Step 4: Join A, B ; B, C ; C, D and D, A to complete the rhombus.

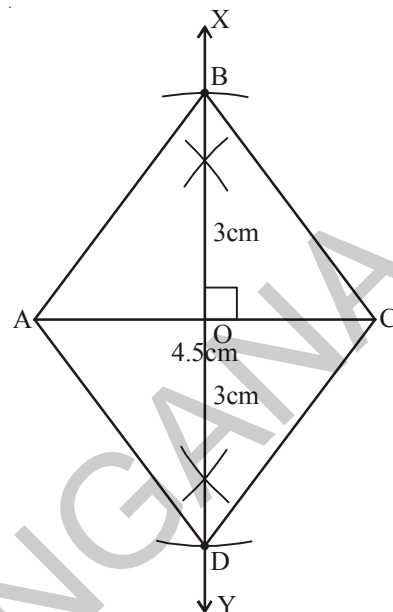

Think, Discuss and Write

1. Can you construct the above quadrilateral (rhombus) taking BD as a base instead of AC? If not give reason.
2. Suppose the two diagonals of this rhombus are equal in length, what figure did you obtain? Draw a rough sketch for it. State reasons.



Exercise - 3.6

Construct quadrilaterals for measurements given below :

- (a) A rhombus CART with CR = 6 cm, AT = 4.8 cm
- (b) A rhombus SOAP with SA = 4.3 cm, OP = 5 cm
- (c) A square JUMP with diagonal 4.2 cm.



What we have discussed

- Five independent measurements are required to draw a unique quadrilateral
- A quadrilateral can be constructed uniquely, if
 - The lengths of four sides and one angle are given
 - The lengths of four sides and one diagonal are given
 - The lengths of three sides and two diagonals are given
 - The lengths of two adjacent sides and three angles are given
 - The lengths of three sides and two included angles are given
- The two special quadrilaterals, namely rhombus and square can be constructed when two diagonals are given.



Note to Teachers

Angles constructed by using compass are accurate and can be proved logically, whereas the protractor can be used for measurement and verification. So let our students learn to construct all possible angles with the help of compass.

Fun with Paper Cutting

Tile and Smile

Cut a quadrilateral from a paper as shown in the figure. Locate the mid points of its sides, and then cut along the segments joining successive mid points to give four triangles T_1, T_2, T_3, T_4 and a parallelogram P.

Can you show that the four triangular tiles make a parallelogram. How does the area of the parallelogram compare to the area of the original quadrilateral?

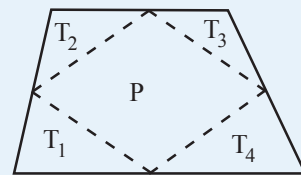

Just for fun

Quadrilateral + Quadrilateral = Parallelogram?

Fold a sheet of paper in half, and then use scissors to cut a pair of congruent quadrilaterals. Cut one of the quadrilateral along one of the diagonals, and cut the second quadrilateral along the other diagonal. Show that four triangles can be arranged to form a parallelogram.

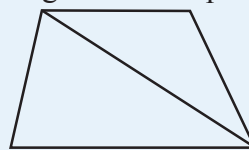
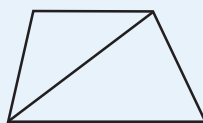



4.0 Introduction

We know that $3 \times 3 \times 3 \times 3 \times 3 \times 3 = 3^6$ and

$$3 \times 3 \times 3 \times 3 \times 3 \times \dots \dots \dots (m \text{ times}) = 3^m$$

- (i) The estimated diameter of the sun is 1,40,00,00,000 m and
- (ii) Mass of the sun is 1, 989, 100, 000, 000, 000, 000, 000, 000, 000 kg
- (iii) The distance from the Sun to Earth is 149, 600, 000, 000 m.
- (iv) The universe is estimated to be about 12,000,000,000 years old.
- (v) The earth has approximately 1,353,000,000 cubic km of sea water.

In a chess board there are 64 boxes. Let us fill each square of a chess board is filled with grain like this. First box is filled with one grain and remaining boxes are filled in such a way that number of grains in a box is double of the previous box. Do you know how many number of grains required to fill all 64 boxes? It is 18,446,744,073,709,551,615.

Can we read, write and understand such large numbers? Try to recall how we have written these kinds of numbers using exponents.

$$1,40,00,00,000 \text{ m} = 1.4 \times 10^9 \text{ m.}$$

We read 10^9 as 10 raised to the power of 9.

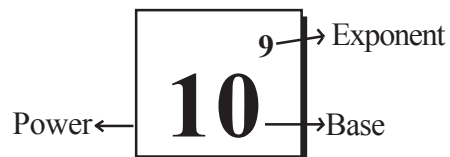

Do This

1. Simplify the following-

$$(i) 3^7 \times 3^3 \quad (ii) 4 \times 4 \times 4 \times 4 \times 4 \quad (iii) 3^4 \times 4^3$$

2. The distance between Hyderabad and Delhi is 1674.9 km by rail. How would you express this in centimeters? Also express this in the scientific form.

4.1 Powers with Negative Exponents

Usually we write

$$\text{Diameter of the sun} = 1,40,00,00,000 \text{ m} = 1.4 \times 10^9 \text{ m}$$

$$\text{Avagadro number} = 6.023 \times 10^{23}$$

These numbers are large numbers and conveniently represented in exponential form.

But how we represent very small numbers even less than unit in exponential form?

For example

$$\text{Thickness of hair} = 0.000005 \text{ m}$$

$$\text{Thickness of micro film} = 0.000015 \text{ m}$$

Let us observe how we can represent these numbers that are less than a unit.

Let us recall the following patterns from the earlier classes.

$$10^3 = 10 \times 10 \times 10 = 1000$$

$$10^2 = 10 \times 10 = 100 = 1000/10$$

$$10^1 = 10 = 100/10$$

$$10^0 = 1 = 10/10$$

$$10^{-1} = ?$$

As the exponent decreases by 1, the value becomes one-tenth of the previous value.

Continuing the above pattern we can say that $10^{-1} = \frac{1}{10}$

$$\text{Similarly } 10^{-2} = \frac{1}{10} \div 10 = \frac{1}{10} \times \frac{1}{10} = \frac{1}{100} = \frac{1}{10^2}$$

$$10^{-3} = \frac{1}{100} \div 10 = \frac{1}{100} \times \frac{1}{10} = \frac{1}{1000} = \frac{1}{10^3}$$

From the above illustrations we can say $\frac{1}{10^n} = 10^{-n}$ or $\frac{1}{10^{-n}} = 10^n$

Observe the following table:

1 kilometre	1 hectometre	1 decametre	1 metre	1 decimeter	1 centimetre	1 millimetre
1000m	100m	10m	1 m	$\frac{1}{10}$ m	$\frac{1}{100}$ m	$\frac{1}{1000}$ m
10^3 m	10^2 m	10^1 m	10^0 m	10^{-1} m	10^{-2} m	10^{-3} m



Do This

What is 10^{-10} equal to?

Observe the pattern-

$$(i) \quad 8 = 2 \times 2 \times 2 = 2^3$$

$$(ii) \quad \frac{8}{2} = 4 = 2 \times 2 = 2^2$$

$$(iii) \quad \frac{4}{2} = 2 = 2^1$$

$$(iv) \quad \frac{2}{2} = 1 = 2^0$$

$$(v) \quad \frac{1}{2} = 2^{-1}$$

$$(vi) \quad \frac{1}{2^2} = 2^{-2}$$

In general we can say that for any non zero integer 'a', $a^{-m} = \frac{1}{a^m}$, which is the multiplicative inverse of a^m . (How ?)

$$\text{That is } a^m \times a^{-m} = a^{m+(-m)} = a^0 = 1$$



Do This

Find the multiplicative inverse of the following

$$(i) \quad 3^{-5} \qquad (ii) \quad 4^{-3} \qquad (iii) \quad 7^{-4} \qquad (iv) \quad 7^{-3}$$

$$(v) \quad x^{-n} \qquad (vi) \quad \frac{1}{4^3} \qquad (vii) \quad \frac{1}{10^3}$$

Look at this!

We know that, $\text{speed} = \frac{\text{distance}}{\text{time}}$. Writing this symbolically, $s = \frac{d}{t}$. When distance is expressed in meters (**m**) and time in seconds(**s**), the unit for speed is written as $\mathbf{m} \times \mathbf{s}^{-1}$.

Similarly the unit for acceleration is $\frac{m}{s^2}$, which can also be expressed as $\mathbf{m} \times \mathbf{s}^{-2}$.

We can express the numbers like 3456 in the expanded form as follows :

$$3456 = (3 \times 1000) + (4 \times 100) + (5 \times 10) + (6 \times 1)$$

$$3456 = (3 \times 10^3) + (4 \times 10^2) + (5 \times 10) + (6 \times 10^0)$$

Similarly $7405 = (7 \times 10^3) + (4 \times 10^2) + (0 \times 10) + (5 \times 10^0)$

Now let us see how we can express the decimal numbers like 326.57 in the expanded form by using exponentials.

$$326.57 = (3 \times 10^2) + (2 \times 10) + (6 \times 10^0) + \left(\frac{5}{10}\right) + \left(\frac{7}{10^2}\right)$$

$$= (3 \times 10^2) + (2 \times 10) + (6 \times 10^0) + (5 \times 10^{-1}) + (7 \times 10^{-2})$$

(We have

$$\frac{1}{10} = 10^{-1} \text{ \& } \frac{1}{10^2} = 10^{-2})$$

$$\text{Also } 734.684 = (7 \times 10^2) + (3 \times 10) + (4 \times 10^0) + \left(\frac{6}{10}\right) + \left(\frac{8}{10^2}\right) + \left(\frac{4}{10^3}\right)$$

$$= (7 \times 10^2) + (3 \times 10) + (4 \times 10^0) + (6 \times 10^{-1}) + (8 \times 10^{-2}) + (4 \times 10^{-3})$$



Do This

Expand the following numbers using exponents.

- (i) 543.67 (ii) 7054.243 (iii) 6540.305 (iv) 6523.450

4.2 Laws of Exponents

We have learnt that for any non-zero integer 'a', $a^m \times a^n = a^{m+n}$; where 'm' and 'n' are natural numbers.

Does this law also hold good for negative exponents? Let us verify.

- (i) Consider $3^2 \times 3^{-4}$

$$\text{We know that } 3^{-4} = \frac{1}{3^4}$$

$$a^{-m} = \frac{1}{a^m} \text{ for any non zero integer 'a'}$$

$$\text{Therefore } 3^2 \times 3^{-4} = 3^2 \times \frac{1}{3^4} = \frac{3^2}{3^4}$$

$$= 3^{2-4} = 3^{-2}$$

$$\text{We know that } \frac{a^m}{a^n} = a^{m-n}, \text{ where } m > n$$

$$\text{i.e., } 3^2 \times 3^{-4} = 3^{-2}$$

- (ii) Take $(-2)^{-3} \times (-2)^{-4}$

$$(-2)^{-3} \times (-2)^{-4} = \frac{1}{(-2)^3} \times \frac{1}{(-2)^4} = \frac{1}{(-2)^{3+4}} \quad (\because a^m \times a^n = a^{m+n})$$

$$= \frac{1}{(-2)^7} = (-2)^{-7} \quad (\because \frac{1}{a^m} = a^{-m})$$

Therefore $(-2)^{-3} \times (-2)^{-4} = (-2)^{-7}$ ($\because a^m \times a^n = a^{m+n}$)

(iii) Let us take $(-5)^2 \times (-5)^{-5}$

$$\begin{aligned} (-5)^2 \times (-5)^{-5} &= (-5)^2 \times \frac{1}{(-5)^5} \\ &= \frac{1}{(-5)^{5-2}} = \frac{1}{(-5)^3} \quad \left(\because \frac{a^m}{a^n} = \frac{1}{a^{n-m}} \right) \\ &= (-5)^{-3} \quad \left(\because \frac{1}{a^m} = a^{-m} \right) \end{aligned}$$

Therefore $(-5)^2 \times (-5)^{-5} = (-5)^{-3}$ (We know $2+(-5) = -3$)

In general, we can infer that for any non-zero integer 'a', $a^m \times a^n = a^{m+n}$; where 'm' and 'n' are integers.



Do This

Simplify and express the following as single exponent.

(i) $2^{-3} \times 2^{-2}$

(ii) $7^{-2} \times 7^5$

(iii) $3^4 \times 3^{-5}$

(iv) $7^5 \times 7^{-4} \times 7^{-6}$

(v) $m^5 \times m^{-10}$

(vi) $(-5)^{-3} \times (-5)^{-4}$

Similarly, we can also verify the following laws of exponents where 'a' and 'b' are non zero integers and 'm' and 'n' are any integers.

1. $\frac{a^m}{a^n} = a^{m-n}$

2. $(a^m)^n = a^{mn}$

3. $(a^m \times b^m) = (ab)^m$

You have studied these laws in lower classes only for positive exponents (Whole Numbers).

$$4. \quad \frac{a^m}{b^m} = \left(\frac{a}{b}\right)^m$$

$$5. \quad a^0 = 1$$

Do you find any relation between 'm' and 'n' if $a^m = a^n$, where 'a' is a non zero integer and $a \neq 1, a \neq -1$. Let us see:

$$\text{Let } a^m = a^n \quad \text{then } \frac{a^m}{a^n} = 1 \text{ (Dividing both sides by } a^n)$$

$$\text{That is } a^{m-n} = 1. \quad a^{m-n} = a^0$$

$$\therefore m - n = 0$$

$$\therefore m = n$$

Why $a \neq 1$?

If $a = 1, m = 7$ and $n = 6$ then $1^7 = 1^6$

$\Rightarrow 7 = 6$, is it true?

So $a \neq 1, a \neq -1$, then what happens?

Thus we can conclude that if $a^m = a^n$ then $m = n$.

Example 1: Find the value of (i) 5^{-2} (ii) $\frac{1}{2^{-5}}$ (iii) $(-5)^2$

$$\text{Solution: (i) } 5^{-2} = \frac{1}{(5)^2} = \frac{1}{5 \times 5} = \frac{1}{25} \quad (\because a^{-m} = \frac{1}{a^m})$$

$$\text{(ii) } \frac{1}{2^{-5}} = 2^5 = 2 \times 2 \times 2 \times 2 \times 2 \quad (\because \frac{1}{a^{-m}} = a^m)$$

$$2^5 = 32$$

$$\text{(iii) } (-5)^2 = (-5)(-5) = 25$$

Example 2: Simplify the following

$$\text{(i) } (-5)^4 \times (-5)^{-6} \quad \text{(ii) } \frac{4^7}{4^4} \quad \text{(iii) } \left(\frac{3^5}{3^3}\right)^5 \times 3^{-6}$$

$$\text{Solution: (i) } (-5)^4 \times (-5)^{-6} \quad (\because a^m \times a^n = a^{m+n})$$

$$= (-5)^{4+(-6)} = (-5)^{-2}$$

$$= \frac{1}{(-5)^2} = \frac{1}{(-5) \times (-5)} = \frac{1}{25} \quad (\because a^{-m} = \frac{1}{a^m})$$

$$\text{(ii) } \frac{4^7}{4^4} \quad (\because \frac{a^m}{a^n} = a^{m-n})$$

$$= 4^{7-4} = 4^3 = 64$$

$$\begin{aligned}
 \text{(iii)} \quad & \left(\frac{3^5}{3^3}\right)^5 \times 3^{-6} \\
 & = (3^{5-3})^5 \times 3^{-6} && (\because \frac{a^m}{a^n} = a^{m-n}) \\
 & = (3^2)^5 \times 3^{-6} && (\because (a^m)^n = a^{mn}) \\
 & = 3^{10} \times 3^{-6} = 3^4 = 81
 \end{aligned}$$

Example 3: Express each of the following with positive exponents.

$$\text{(i)} 4^{-7} \quad \text{(ii)} \frac{1}{(5)^{-4}} \quad \text{(iii)} \left(\frac{4}{7}\right)^{-3} \quad \text{(iv)} \frac{7^{-4}}{7^{-6}}$$

Solution : (i) 4^{-7} (We know $a^{-m} = \frac{1}{a^m}$)

$$= \frac{1}{(4)^7}$$

$$\begin{aligned}
 \text{(ii)} \quad & \frac{1}{(5)^{-4}} \\
 & = 5^4
 \end{aligned}$$

$$(\because \frac{1}{a^{-m}} = a^m)$$

$$\text{(iii)} \quad \left(\frac{4}{7}\right)^{-3} = \frac{4^{-3}}{7^{-3}}$$

$$\left(a^{-m} = \frac{1}{a^m} \text{ and } a^m = \frac{1}{a^{-m}}\right)$$

$$= \frac{7^3}{4^3} = \left(\frac{7}{4}\right)^3$$

$$\therefore \left(\frac{a}{b}\right)^{-m} = \left(\frac{b}{a}\right)^m$$

$$\text{(iv)} \quad \frac{7^{-4}}{7^{-6}}$$

$$= 7^{-4 - (-6)}$$

$$= 7^{-4+6} = 7^2$$



Example 4: Express 27^{-4} as a power with base 3

Solution : 27 can be written as $3 \times 3 \times 3 = 3^3$

$$\text{Therefore } 27^{-4} = (3^3)^{-4}$$

$$= 3^{-12}$$

$$(\because (a^m)^n = a^{mn})$$

Example 5: Simplify

(i) $\left(\frac{1}{27}\right) \times 2^{-3}$ (ii) $4^4 \times 16^{-2} \times 4^0$

Solution: (i) $\left(\frac{1}{27}\right) \times 2^{-3}$

27 can be expressed as $3 \times 3 \times 3 = 3^3$

So, $\left(\frac{1}{27}\right) \times 2^{-3} = \frac{1}{3^3} \times 2^{-3}$ $\therefore \frac{1}{a^m} = a^{-m}$
 $= 3^{-3} \times 2^{-3}$ $\therefore a^m \times b^m = (ab)^m$
 $= (3 \times 2)^{-3} = \frac{1}{(3 \times 2)^3}$
 $= \frac{1}{6^3} = \frac{1}{216}$

(ii) $4^4 \times 16^{-2} \times 4^0$
 $= 4^4 \times (4^2)^{-2} \times 4^0$ $(\because (a^m)^n = a^{mn})$
 $= 4^4 \times 4^{-4} \times 4^0$ $(\because a^m \times a^n = a^{m+n})$
 $= 4^{4-4+0} = 4^0$ $(\because a^0 = 1)$
 $= 1$

Example 6: Guess the value of 'x' when $2^x = 1$

Solution: as we discussed before $a^0 = 1$

$\therefore 2^x = 1$
 $2^x = 2^0$
 $\Rightarrow x = 0$

Example 7: Find the value of 'x' such that

(i) $25 \times 5^x = 5^8$ (ii) $\frac{1}{49} \times 7^{2x} = 7^8$
(iii) $(3^6)^4 = 3^{12x}$ (iv) $(-2)^{x+1} \times (-2)^7 = (-2)^{12}$

Solution : (i) $25 \times 5^x = 5^8$

$$5^2 \times 5^x = 5^8$$

$$5^{2+x} = 5^8$$

$$2 + x = 8$$

$$\therefore x = 6$$

(as $25 = 5 \times 5 = 5^2$)

But $a^m \times a^n = a^{m+n}$

If $a^m = a^n \Rightarrow m = n$

(ii) $\frac{1}{49} \times 7^{2x} = 7^8$

$$\Rightarrow \frac{1}{7^2} \times 7^{2x} = 7^8$$

$$(\because \frac{1}{a^m} = a^{-m})$$

$$7^{-2} \times 7^{2x} = 7^8$$

$$7^{2x-2} = 7^8$$

As bases are equal, Hence

$$2x - 2 = 8$$

$$2x = 8 + 2$$

$$2x = 10$$

$$x = \frac{10}{2} = 5$$

$$\therefore x = 5$$

(iii) $(3^6)^4 = 3^{12x}$

$$[\because (a^m)^n = a^{mn}]$$

$$3^{24} = 3^{12x}$$

As bases are equal, Hence

$$24 = 12x$$

$$\therefore x = \frac{24}{12} = 2$$

(iv) $(-2)^{x+1} \times (-2)^7 = (-2)^{12}$

$$(-2)^{x+1+7} = (-2)^{12}$$

$$(-2)^{x+8} = (-2)^{12}$$

As bases are equal, Hence

$$x + 8 = 12$$

$$\therefore x = 12 - 8 = 4$$

Example 8 : Simplify $\left(\frac{2}{5}\right)^{-3} \times \left(\frac{25}{4}\right)^{-2}$

Solution: $\frac{25}{4} = \frac{5 \times 5}{2 \times 2} = \frac{5^2}{2^2}$

$$\left(\frac{2}{5}\right)^{-3} \times \left(\frac{25}{4}\right)^{-2} = \left(\frac{2}{5}\right)^{-3} \times \left(\frac{5^2}{2^2}\right)^{-2} \quad (\because (a^m)^n = a^{mn})$$

$$= \frac{5^3}{2^3} \times \frac{2^4}{5^4} = 5^{3-4} \times 2^{4-3}$$

$$= 5^{-1} \times 2^1 = \frac{2}{5}$$

$\therefore \text{As } \frac{a^m}{a^n} = a^{m-n}$

Example 9 : Simplify $\left[\left\{ \left(\frac{1}{3}\right)^{-3} - \left(\frac{1}{2}\right)^{-3} \div \left(\frac{1}{5}\right)^{-2} \right\} \right]$

Solution: $\left[\left(\frac{1}{3}\right)^{-3} - \left(\frac{1}{2}\right)^{-3} \div \left(\frac{1}{5}\right)^{-2} \right] \quad (\because \left(\frac{a}{b}\right)^m = \frac{a^m}{b^m})$

$$= \left[\left(\frac{1^{-3}}{3^{-3}} - \frac{1^{-3}}{2^{-3}} \right) \div \frac{1^{-2}}{5^{-2}} \right] \quad (\because a^{-m} = \frac{1}{a^m} \text{ and } a^m = \frac{1}{a^{-m}})$$

$$= \left[\left(\frac{3^3}{1^3} - \frac{2^3}{1^3} \right) \div \frac{5^2}{1^2} \right] = \left(\frac{27}{1} - \frac{8}{1} \right) \div 25$$

$$= (27 - 8) \div 25 = \frac{19}{25}$$

Example 10 : If $x = \left(\frac{3}{2}\right)^2 \times \left(\frac{2}{3}\right)^{-4}$ find the value of x^{-2}

Solution: $x = \left(\frac{3}{2}\right)^2 \times \left(\frac{2}{3}\right)^{-4}$

$$x = \left(\frac{3}{2}\right)^2 \times \frac{2^{-4}}{3^{-4}} \quad (\because \left(\frac{a}{b}\right)^m = \frac{a^m}{b^m})$$

$$x = \frac{3^2}{2^2} \times \frac{3^4}{2^4} = \frac{3^{2+4}}{2^{2+4}} = \frac{3^6}{2^6} = \left(\frac{3}{2}\right)^6$$

$$x = \left(\frac{3}{2}\right)^6$$

$$x^{-2} = \left[\left(\frac{3}{2}\right)^6\right]^{-2} = \left(\frac{3}{2}\right)^{-12} = \frac{3^{-12}}{2^{-12}} = \frac{2^{12}}{3^{12}} = \left(\frac{2}{3}\right)^{12}$$



Exercise - 4.1

1. Simplify and give reasons

(i) 4^{-3} (ii) $(-2)^7$ (iii) $\left(\frac{3}{4}\right)^{-3}$ (iv) $(-3)^{-4}$

2. Simplify the following :

(i) $\left(\frac{1}{2}\right)^4 \times \left(\frac{1}{2}\right)^5 \times \left(\frac{1}{2}\right)^6$ (ii) $(-2)^7 \times (-2)^3 \times (-2)^4$

(iii) $4^4 \times \left(\frac{5}{4}\right)^4$ (iv) $\left(\frac{5^{-4}}{5^{-6}}\right) \times 5^3$ (v) $(-3)^4 \times 7^4$

3. Simplify (i) $2^2 \times \frac{3^2}{2^{-2}} \times 3^{-1}$ (ii) $(4^{-1} \times 3^{-1}) \div 6^{-1}$

4. Simplify and give reasons

(i) $(4^0 + 5^{-1}) \times 5^2 \times \frac{1}{3}$ (ii) $\left(\frac{1}{2}\right)^{-3} \times \left(\frac{1}{4}\right)^{-3} \times \left(\frac{1}{5}\right)^{-3}$

(iii) $(2^{-1} + 3^{-1} + 4^{-1}) \times \frac{3}{4}$ (iv) $\frac{3^{-2}}{3} \times (3^0 - 3^{-1})$

(v) $1 + 2^{-1} + 3^{-1} + 4^0$ (vi) $\left[\left(\frac{3}{2}\right)^{-2}\right]^2$

5. Simplify and give reasons (i) $\left[(3^2 - 2^2) \div \frac{1}{5}\right]^2$ (ii) $((5^2)^3 \times 5^4) \div 5^6$
6. Find the value of 'n' in each of the following :
- (i) $\left(\frac{2}{3}\right)^3 \times \left(\frac{2}{3}\right)^5 = \left(\frac{2}{3}\right)^{n-2}$
- (ii) $(-3)^{n+1} \times (-3)^5 = (-3)^{-4}$
- (iii) $7^{2n+1} \div 49 = 7^3$
7. Find 'x' if $2^{-3} = \frac{1}{2^x}$
8. Simplify $\left[\left(\frac{3}{4}\right)^{-2} \div \left(\frac{4}{5}\right)^{-3}\right] \times \left(\frac{3}{5}\right)^{-2}$
9. If $m = 3$ and $n = 2$ find the value of
- (i) $9m^2 - 10n^3$ (ii) $2m^2 n^2$ (iii) $2m^3 + 3n^2 - 5m^2 n$ (iv) $m^n - n^m$
10. Simplify and give reasons $\left(\frac{4}{7}\right)^{-5} \times \left(\frac{7}{4}\right)^{-7}$

4.3 Application of Exponents to Express numbers in Standard Form

In previous class we have learnt how to express very large numbers in standard form.

For example $300,000,000 \text{ m} = 3 \times 10^8 \text{ m}$

Now let us try to express very small number in standard form.

Consider, diameter of a wire in a computer chip is 0.000003 m

$$0.000003 \text{ m} = \frac{3}{1000000} \text{ m}$$

$$= \frac{3}{10^6} \text{ m}$$

$$= 3 \times 10^{-6} \text{ m}$$

Therefore, $0.000003 \text{ m} = 3 \times 10^{-6} \text{ m}$

Similarly consider the size of plant cell which is 0.00001275m

$$\begin{aligned} 0.00001275\text{m} &= \frac{1275}{100000000} \text{ m} \\ &= 1.275 \times \frac{10^3}{10^8} \text{ m} \\ &= 1.275 \times 10^{-5} \text{ m} \end{aligned}$$



Do This

1. Change the numbers into standard form and rewrite the statements.
 - (i) The distance from the Sun to earth is 149,600,000,000m
 - (ii) The average radius of Sun is 695000 km
 - (iii) The thickness of human hair is in the range of 0.08 mm - 0.12 mm
 - (iv) The height of Mount Everest is 8848 m
2. Write the following numbers in the standard form

(i) 0.0000456	(ii) 0.000000529	(iii) 0.0000000085
(iv) 6020000000	(v) 35400000000	(vi) 0.000437×10^4

4.4 Comparing very large and very small numbers

We know that the diameter of the Sun is 1400000000 m. and earth is 12750000 m. If we want to know how bigger the Sun is than the Earth, we have to divide the diameter of Sun by the diameter of the Earth.

$$\text{i.e. } \frac{1400000000}{12750000}$$

This is difficult to do but if we write these diameters in standard form then it is easy to find how big the Sun in comparison to the Earth.

$$\text{Diameter of the Sun} = 1400000000 \text{ m} = 1.4 \times 10^9 \text{ m}$$

$$\text{Diameter of the Earth} = 12750000 = 1.275 \times 10^7 \text{ m}$$

$$\begin{aligned} \text{Therefore we have, } \frac{\text{Diameter of the sun}}{\text{Diameter of the earth}} &= \frac{1.4 \times 10^2 \times 10^7}{1.275 \times 10^7} \\ &= \frac{1.4 \times 10^2}{1.275} \\ &\cong 10^2 = 100 \quad (\text{Approximately}) \end{aligned}$$

Thus the diameter of the Sun is approximately 100 times the diameter of the Earth. So the Sun is 100 times bigger than the Earth.

Let us consider one more illustration

The mass of the earth is 5.97×10^{24} kg and the mass of the moon is 7.35×10^{22} kg.

What is their total mass?

$$\text{The mass of the earth} = 5.97 \times 10^{24} \text{ kg}$$

$$\text{The mass of the moon} = 7.35 \times 10^{22} \text{ kg}$$

$$\begin{aligned} \text{Total Mass} &= 5.97 \times 10^{24} \text{ Kg} + 7.35 \times 10^{22} \text{ kg} \\ &= (5.97 \times 10^2 \times 10^{22} \text{ Kg}) + 7.35 \times 10^{22} \text{ kg} \\ &= (5.97 \times 10^2 + 7.35) \times 10^{22} \text{ kg} \\ &= (597 + 7.35) \times 10^{22} \text{ kg} \\ &= 604.35 \times 10^{22} \text{ kg} \\ &= 6.0435 \times 10^{24} \text{ kg} \end{aligned}$$

When we have to add numbers in the standard form we convert them in numbers with same exponents.

Example 11 : Express the following in the usual form.

(i) 4.67×10^4 (ii) 1.0001×10^9 (iii) 3.02×10^{-6}

Solution:

(i) $4.67 \times 10^4 = 4.67 \times 10000 = 46700$

(ii) $1.0001 \times 10^9 = 1.0001 \times 1000000000 = 1000100000$

(iii) $3.02 \times 10^{-6} = 3.02/10^6 = 3.02/1000000 = 0.00000302$



Exercise - 4.2

1. Express the following numbers in standard form.

(i) 0.000000000947 (ii) 543000000000
(iii) 48300000 (iv) 0.00009298 (v) 0.0000529

2. Express the following numbers in usual form.

(i) 4.37×10^5 (ii) 5.8×10^7 (iii) 32.5×10^{-4} (iv) 3.71529×10^7
(v) 3789×10^{-5} (vi) 24.36×10^{-3}

3. Express the following information in standard form

- (i) Size of the bacteria is 0.0000004 m
(ii) The size of red blood cells is 0.000007mm

- (iii) The speed of light is 300000000 m/sec
- (iv) The distance between the moon and the earth is 384467000 m(app)
- (v) The charge of an electron is 0.0000000000000000016 coulombs
- (vi) Thickness of a piece of paper is 0.0016 cm
- (vii) The diameter of a wire on a computer chip is 0.000005 cm
4. In a pack, there are 5 books, each of thickness 20 mm and 5 paper sheets each of thickness 0.016mm. What is the total thickness of the pack.
5. Rakesh solved some problems of exponents in the following way. Do you agree with the solutions? If not why? Justify your argument.

(i) $x^{-3} \times x^{-2} = x^{-6}$

(ii) $\frac{x^3}{x^2} = x^4$

(iii) $(x^2)^3 = x^{2^3} = x^8$

(iv) $x^{-2} = \sqrt{x}$

(v) $3x^{-1} = \frac{1}{3x}$



Project work

Refer science text books of 6th to 10th classes in your school and collect some scientific facts involving very small numbers and large numbers and write them in standard form using exponents.



What we have discussed

1. Numbers with negative exponents holds the following laws of exponents.

(a) $a^m \times a^n = a^{m+n}$ (b) $\frac{a^m}{a^n} = a^{m-n} = \frac{1}{a^{n-m}}$ (c) $(a^m)^n = a^{mn}$

(c) $a^m \times b^m = (ab)^m$ (d) $a^0 = 1$ (e) $\frac{a^m}{b^m} = \left(\frac{a}{b}\right)^m$

2. Very small numbers can be expressed in standard form using negative exponents.
3. Comparison of smaller and larger numbers.
4. Identification of common errors.



Comparing quantities using Proportion



W4U5W3

5.0 Introduction

In our day-to-day activities, some times we need to compare quantities. We learnt that ratio and percentages are used to compare quantities. Let us consider the following example.

Voting was conducted for class mentor, in a class of 40 students. Snigdha became first mentor by getting 24 votes and Siri became second mentor by getting 16 votes. So the ratio of votes polled to Snigdha and Siri is 24 : 16. After simplification, what is its ratio? It is 3:2.

Inversely the ratio of votes polled to Siri and Snigdha is 2:3. Can you say what a ratio is?

A **Ratio** is an **ordered** comparison of two quantities.



Try These

1. Find the ratio of gears of your bicycle.

Count the number of teeth of the chain wheel and the number of teeth of the sprocket wheel.

$$\left\{ \begin{array}{l} \text{number of teeth of} \\ \text{the chain wheel} \end{array} \right\} : \left\{ \begin{array}{l} \text{number of teeth} \\ \text{of Sprocket wheel} \end{array} \right\}$$

This is called gear ratio. Write the number of times the Sprocket wheel turns for every time the chain wheel rotates.

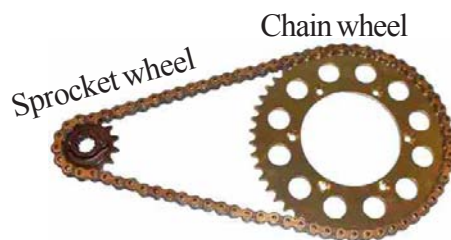

2. Collect News Paper cuttings related to percentages of any five different situations.

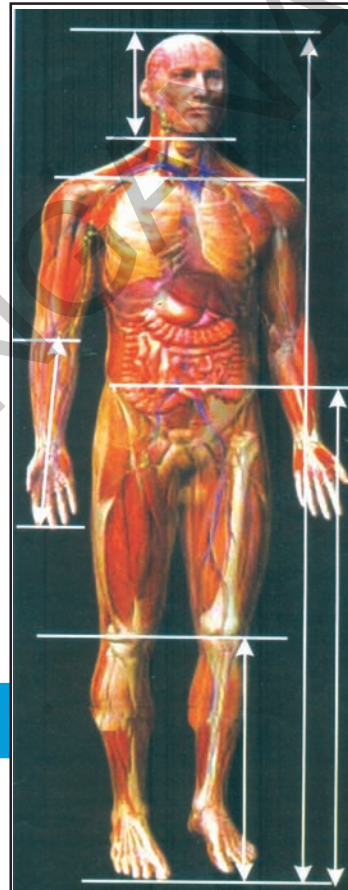

Golden Ratio in the Human body 1.615:1 is Golden ratio

Human beings are no exception to the golden ratio. In fact, our body architecture is one of the most perfect examples of this 'Divine proportion'.

Consider the following:

- Height: length between naval point and foot
- Length between shoulder line: length of the head.
- Length between finger tip to elbow: length between wrist and elbow
- Length between naval point to knee: length between knee and foot.

























Compound Ratio

Some times we have to express two ratios as a single ratio. Why? Let us consider the following example to understand this.

Ramayya and Gopalam started a business with an investment of ₹ 2000 and ₹ 3000. At the end of the year in what ratio would they have to divide the annual profit obtained?

$$\begin{aligned} \text{Ratio of investments} &= 2000: 3000 \\ &= 2: 3 \end{aligned}$$

Investments throughout the year are given below.

Month	Jan	Feb	Mar	Apr	May	Jun	Jul	Aug	Sep	Oct	Nov	Dec	Total shares
Ramayya's shares													24
Gopalam's shares													36

$$\begin{aligned} \text{Ratio of their shares} &= 24: 36 \\ &= 2: 3 \text{ and ratio of time period} = 1:1 \end{aligned}$$

What do you observe? Ratio of investments is equal to ratio of shares when time period is the same. So they will divide the profit in the ratio of their shares. So annual profit is to be divided in the ratio of 2:3

In the above example,

Case 1 : Suppose they both started the business with the same amount of ₹ 5000, but Ramayya did business for a period of 12 months and Gopalam for a period of 9 months. How do they share the same profit? Do you say that because they started the business with the same amount, they have to divide the profit in the same ratio at the year ending?

Ratio of their investments = 5000: 5000 = 1:1

Month	Jan	Feb	Mar	Apr	May	Jun	Jul	Aug	Sep	Oct	Nov	Dec	Total shares
Ramayya's shares													12
Gopalam's shares										-	-	-	9

Ratio of shares = 12: 9 = 4:3

and Ratio of time periods = 12: 9 = 4: 3

Their investment is the same, so they share the profit in the ratio of their shares i.e. ratio of their time period.

Case 2 : Further suppose Ramayya invested an amount of ₹ 2000 for 12 months and Gopalam invested an amount of ₹ 3000 for 9 months. In what ratio they have to divide the annual profit? Is it the ratio of investments or ratio of time period? Ramayya invested less amount but for more period. Gopalam invested more amount but for less period. Here we have to give importance for their investments as well as their investment periods. How to do that?

Ratio of investments = 2000: 3000 = 2:3

Ratio of time periods = 12: 9 = 4:3

Month	Jan	Feb	Mar	Apr	May	Jun	Jul	Aug	Sep	Oct	Nov	Dec	Total shares
Ramayya's shares													24
Gopalam's shares										-	-	-	27

Ratio of shares = 24 : 27 = 8 : 9

= (2 × 12) : (3 × 9) = 8 : 9 (observe above table)

Here the ratio of investments is 2:3 and the ratio of time period is 4 : 3. So the ratio of shares is (2 × 12) : (3 × 9) = 8 : 9. Hence they have to divide the annual profit in the ratio of 8 : 9. Do you find any relation between ratio of investment and time period and ratio of shares?

The ratio of shares can be written as $8 : 9 = \underbrace{2 : 3} \quad \underbrace{:: \quad 4 : 3}$
 Product of antecedents Product of consequents

Two simple ratios are expressed in the form of single ratio as the ratio of product of antecedents to product of consequents and we call it **Compound ratio** of the given two simple ratios i.e. ratios are compounded by multiplying together the fractions which denote them.

$a : b$ and $c : d$ are any two ratios, then their compound ratio is $\frac{a}{b} \times \frac{c}{d} = \frac{ac}{bd}$ i.e. $ac : bd$.



Try These

- Find the compound ratios of the following.
 (a) $3 : 4$ and $2 : 3$ (b) $4 : 5$ and $4 : 5$ (c) $5 : 7$ and $2 : 9$
- Give examples of compound ratio from daily life.

Percentage:

Consider the following example.

M. K. Nagar high school students decided to sell tickets of a charity show. Class VIII students have 300 tickets to sell and class VII students have 250 tickets to sell. One hour before the show, eighth class students sold 225 tickets and seventh class students sold 200 tickets. Which class students were closer to the goal of selling all their tickets?

To figure out which class students were closer to their goal, you may try to compare the ratios $225:300$ and $200:250$. For eighth class students the ratio is $3:4$ and for seventh class students the ratio is $4:5$. Do you compare and say? It is difficult to have a meaningful comparison, hence we can't say directly, we need to have equivalent ratios of both which can be compared. One way to compare quantities is to change them into percentages.

A **percentage (%)** compares a number to 100. The word **percent** means “per every hundred” or “out of every hundred”. $100\% = \frac{100}{100}$. It is also a fraction with denominator 100.

$$\text{Percentage of tickets sold by eighth class students} = \frac{3}{4} \times \frac{100}{100} = \frac{75}{100} = 75\%$$

$$\text{Percentage of tickets sold by seventh class students} = \frac{4}{5} \times \frac{100}{100} = \frac{80}{100} = 80\%$$

From this we understand that seventh class students were closer to the goal of selling all their tickets.

Percentage is number of parts out of 100. So the denominator is to be made 100 for which we are multiplying both numerator and denominator with 100.

Let us consider one example to understand this. We can use percentage as a common scale. In the introductory part, we compared the number of votes polled to Snigdha and Siri by ratio. We can compare the same by percentages also.

The votes polled to Snigdha are 24 out of 40 or 3 out of 5 in the simplified form.
So percentage of votes are $\frac{3}{5} \times 100\% = 60\%$

By other method

Out of 40 votes, number of votes for Snigdha are 24.
So out of 100 votes, number of votes polled to Snigdha
 $= \frac{24}{40} \times 100 = 60$
Out of 100 votes 60 are for her, so percentage of her votes = 60%

Since all the students voted,

Percentage of votes for Snigdha + percentage of votes for Siri = 100%

60% + percentage of votes for Siri = 100%

Thus percentage of votes for Siri = 100% – 60% = 40%

5.1 Finding the increase or decrease percent

Consider the following situation.

- Class sizes have increased by 10%.
- House prices have dropped by 12%.
- CO₂ emissions need to fall by 25% by the year 2020.

Changes in quantities are often expressed as a percentage of the original quantity.

There are two different methods which can be used to solve increase or decrease in percentage problems. Let us see the following examples to understand this.

(1) A sales manager asked his team to increase the sales by 35% over previous month's sales which was ₹ 98,700. What is the target sales ?

Sales in the previous month = ₹ 98,700.

$$35\% \text{ of } ₹ 98,700 = \frac{35}{100} \times 98,700 \\ = ₹ 34,545$$

$$\text{Target sales for the month} \\ = ₹ 98,700 + 34,545 \\ = ₹ 1,33,245.$$

Unitary method.

35% increase means,
₹ 100 increased to ₹ 135.

How much ₹ 98,700 will increase to?

$$\text{Increased sales} = ₹ \frac{135}{100} \times 98,700 \\ = ₹ 1,33,245.$$

Decrease percentage in price would imply the actual decrease followed by its subtraction from the original price.

Let us consider one example to understand this.

The original price of shoes is ₹ 550. They are for sale with a reduction of 10%. What is the new sale price of the shoes?

Original price of shoes = ₹ 550.

Reduction = 10% of ₹ 550
 $= \frac{10}{100} \times 550 = ₹ 55.$

New sale price = original price – reduction
 $= ₹ 550 - ₹ 55 = ₹ 495.$



Think, Discuss and Write

1. Two times a number is 100% increase in the number. If we take half the number what would be the decrease in percent?
2. By what percent is ₹ 2000 less than ₹ 2400? Is it the same as the percent by which ₹ 2400 is more than ₹ 2000?



Exercise - 5.1

1. Find the ratio of the following
 - (i) Smita works in office for 6 hours and Kajal works for 8 hours in her office. Find the ratio of their working hours.
 - (ii) One pot contains 8 litre of milk while other contains 750 milliliter.
 - (iii) speed of a cycle is 15km/h and speed of the scooter is 30km/h.
2. If the compound ratio of 5:8 and 3:7 is 45:x. Find the value of x.
3. If the compound ratio of 7:5 and 8:x is 84:60. Find x.
4. The compound ratio of 3:4 and the inverse ratio of 4:5 is 45:x. Find x.
5. In a primary school there shall be 3 teachers to 60 students. If there are 400 students enrolled in the school, how many teachers should be there in the school in the same ratio?
6. In the adjacent $\triangle ABC$, write all possible ratios by taking measures of sides pair wise.
(Hint : Ratio of AB : BC = 8 : 6)

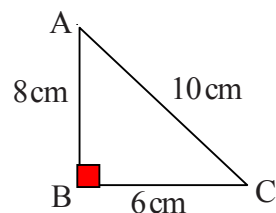

7. If 9 out of 24 students scored below 75% marks in a test. Find the ratio of student scored below 75% marks to the student scored 75% and above marks.
8. Find the ratio of number of vowels in the word 'MISSISSIPPI' to the number of consonants in the simplest form.
9. Rajendra and Rehana own a business. Rehana receives 25% of the profit in each month. If Rehana received ₹ 2080 in particular month, what is the total profit in that month?
10. In triangle ABC, $AB = 2.2$ cm, $BC = 1.5$ cm and $AC = 2.3$ cm. In triangle XYZ, $XY = 4.4$ cm, $YZ = 3$ cm and $XZ = 4.6$ cm. Find the ratio $AB : XY, BC : YZ, AC : XZ$. Are the lengths of corresponding sides of $\triangle ABC$ and $\triangle XYZ$ in proportion?
[Hint : Any two triangles are said to be in proportion, if their corresponding sides are in the same ratio]
11. Madhuri went to a super market. The price changes are as follows. The price of rice reduced by 5% jam and fruits reduced by 8% and oil and dal increased by 10%. Help Madhuri to find the changed prices in the given table.

Item	Original price/kg	Changed price
Rice	₹ 30	
Jam	₹ 100	
Apples	₹ 280	
Oil	₹ 120	
Dal	₹ 80	

12. There were 2075 members enrolled in the club during last year. This year enrolment is decreased by 4%.
(a) Find the decrease in enrolment.
(b) How many members are enrolled during this year?
13. A farmer obtained a yielding of 1720 bags of cotton last year. This year she expects her crop to be 20% more. How many bags of cotton does she expect this year?
14. Points P and Q are both on the line segment AB and on the same side of its midpoint. P divides AB in the ratio 2 : 3, and Q divides AB in the ratio 3 : 4. If $PQ = 2$, then find the length of the line segment AB.

5.2 Finding discounts

In big shops and super markets we see price tag of the articles. Do you know what do we call them? This is called **marked price (M.P.)** of the article. Prices of the items are marked according to the price list quoted by the factory which is called **List price or catalogue price or marked price**

Ravi went to shop to buy a book. Printed price of the book is ₹ 80. But shop owner gave him a discount of 15%. How much amount has Ravi paid to buy the book?

In our daily life we come across so many situations where we are given a price discount on the articles.

Price discount is also called Rebate. It is given on marked price or List Price.

Now in the above example Ravi was given 15% discount. Printed price is ₹ 80. Then the discount will be $\frac{15}{100} \times 80 = ₹ 12$. So the amount he has to pay is ₹ 80 – ₹ 12 = ₹ 68.

Let us see few more examples.

Example 1: A cycle is marked at ₹ 3600 and sold for ₹ 3312. What is the discount and discount percentage ?

Solution: Discount = marked price – sale price
 $= ₹ 3600 - ₹ 3312 = ₹ 288$



Since discount is calculated on marked price. For calculating the discount percentage we use M.P. as the base.

On marked price of ₹ 3600, the discount is ₹ 288

On marked price of ₹ 100, how much will the discount be?

$$\text{Discount percent} = \frac{288}{3600} \times 100 = 8\%$$

We can also find discount when discount percent is given.

Example 2: The marked price of a ceiling fan is ₹ 1600 and the shop keeper allows a discount of 6% on it. Find its selling price.

Solution:

Raju solved it like this.

Discount = 6% of ₹ 1600

$$= \frac{6}{100} \times 1600 = ₹ 96$$

Selling Price = Marked price – discount

$$= ₹ 1600 - ₹ 96$$

$$= ₹ 1504.$$

Latha solved it in a different way.

6% decrease means

₹ 100 decreased to ₹ 94



So ₹ 1600 decreased to?

$$\text{Selling price} = \frac{94}{100} \times 1600 = ₹ 1504$$



Try These

1. Fill the selling price for each.

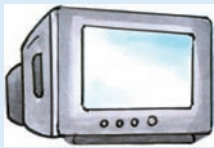
Item	Marked price in ₹	Discount %	Selling price in ₹
	450	7%	
	560	9%	
	250	5%	
	15000	15%	

Example 3: Neelima went to a shop to buy a dress. Marked price of the dress is ₹ 1000. Shop owner gave a discount of 20% and then 5%. Find the single discount equivalent to these two successive discounts.

Solution: Marked price of the article = ₹ 1000.

Percentage of first discount = 20%

First Discount = 20% of 1000

$$= \frac{20}{100} \times 1000 = ₹ 200$$

$$\begin{aligned} \text{Price after first discount} &= ₹ 1000 - ₹ 200 \\ &= ₹ 800. \end{aligned}$$

Percentage of second discount = 5%

Second discount = 5% of ₹ 800

$$= \frac{5}{100} \times 800 = ₹ 40$$

$$\text{Price after second discount} = ₹ 800 - ₹ 40 = ₹ 760.$$

Net selling price = ₹ 760.

20% discount means ₹ 100 is decreased to ₹ 80.

5% discount means ₹ 100 is decreased to ₹ 95.

∴ Net selling price

$$\begin{aligned} &= 1000 \times \frac{80}{100} \times \frac{95}{100} \\ &= ₹ 760 \end{aligned}$$

Single discount equivalent to given discounts = ₹ 1000 – ₹ 760 = ₹ 240.

For ₹ 1000 the discount amount is ₹ 240

$$\text{Percentage of discount given on ₹ 240} = \frac{240}{1000} \times 100 = 24\%$$

What do you observe? Is the given single discount percentage is equivalent to the percentage of two given successive discounts.



Think, Discuss and Write

Preeti went to a shop to buy a dress. Its marked price is ₹ 2500. Shop owner gave 5% discount on it. On further insistence, he gave 3% more discount. What will be the final discount she obtained? Will it be equal to a single discount of 8%? Think, discuss with your friends and write it in your note book.

5.3 Estimation in percentages

Your bill in a shop is ₹ 477.80 and the shop keeper gives a discount of 15%. How would you estimate the amount to be paid?

Round off the bill to the nearest tens. ₹ 477.80 are rounded off to ₹ 480.

Then find 10% of this amount. It is ₹ 48. Take half of this. It is ₹ 24. So discount amount is ₹ 48 + ₹ 24 = ₹ 72. Amount to be paid approximately around ₹ 410.



Try These

(i) Estimate 20% of ₹ 357.30

(ii) Estimate 15% of ₹ 375.50

5.4 Profit and Loss

Prices related to buying and selling (Profit and Loss)

Observe the following situations.

- Sita bought a chair for ₹ 750 and sold it for ₹ 900.
- Mary bought 10g of gold for ₹ 25000 in last year and sold it for ₹ 30,000 in this year.
- Rahim bought a bicycle for ₹ 1600 and next year he sold it for ₹ 1400.
- Anitha purchased a car for ₹ 4.8 lakh and sold it for ₹ 4.1 lakh after 2 years.
- Hari purchased a house for ₹ 9 lakh and incurred an expenditure of ₹ 1 lakh for its repairs. He sold it for ₹ 10.7 lakh.

In the first four examples profit or loss is known by finding the difference between cost price and selling price.

But in the last example, what is the profit obtained by Hari? Is it ₹ 1.7 lakh? Obviously not. He incurred some additional expenditure on it before selling. What do we call such expenditures?

Some times the shop keeper has to spend on additional expenses like transportation, maintenance, labour, repair, commission, rent of godown etc. in addition to the price paid to buy an article. Such additional expenses are called **overhead expenses** and are to be added to the Cost price. Profit or loss is always calculated on this resultant cost price.



Think, Discuss and Write

What happens if cost price = selling price. Do we get any such situations in our daily life?

It is easy to find profit % or loss % in the above situations. But it will be more meaningful if we express them in percentages. Profit % is an example of **increase percent** of cost price and loss % is an example of **decrease percent of cost price**.

Let us see some more examples.

Example 4: Radhika deals with second-hand goods. She bought a second hand refrigerator for ₹ 5000. She spends ₹ 100 on transportation and ₹ 500 on its repair. She sells the refrigerator for ₹ 7000.

Find (i) the total cost price of the refrigerator (ii) profit or loss percent.

Solution: (i) Total cost price = purchasing price + transportation charges + repair charges
 $= ₹ (5000 + 100 + 500) = ₹ 5600$

So the total cost price is ₹ 5600.

(ii) Selling price is ₹ 7000. Here Selling price > cost price, so there is a profit.

Profit = selling price – cost price = ₹ 7000 – ₹ 5600 = ₹ 1400.

On cost price of ₹ 5600 profit is ₹ 1400

If cost price is ₹ 100, profit will be?

$$\text{Profit percent} = \frac{1400}{5600} \times 100 = 25\%$$

Example 5: Vinay bought a flat for ₹ 4,50,000. He spent ₹ 10,000 on its paintings and repair. Then he sold it for ₹ 4,25,500. Find his gain or loss and also its percent.

Solution: Total cost price = purchasing price + repair charges.

$$= ₹ (4,50,000 + 10,000) = ₹ 4,60,000.$$

Selling price is ₹ 4,25,500. Here we can observe Selling price < cost price. So there is a loss.

$$\begin{aligned}\text{Loss} &= \text{cost price} - \text{selling price} \\ &= ₹ 4,60,000 - ₹ 4,25,500 = ₹ 34,500.\end{aligned}$$

For cost price of ₹ 4,60,000 loss is ₹ 34,500 if its cost price is ₹ 100 what will the loss percentage be?

$$\text{Loss percent} = \frac{34,500}{4,60,000} \times 100 = 7.5\%$$

Example 6: Venkanna purchased 50 dozen bananas for ₹ 1250. He incurred transportation charges of ₹ 250. He could not sell five dozen bananas as they were spoiled. He sold the remaining bananas at ₹ 35 for each dozen. Will he get a profit or a loss? Find profit or loss percent.

Solution: Total cost price = Cost price of bananas + Transportation charges
 $= ₹ 1250 + ₹ 250 = ₹ 1500.$

Number of dozens of bananas sold = Number of dozens purchased – number of dozens rotten

$$= 50 - 5 = 45 \text{ dozens}$$

$$\text{Selling price} = ₹ 35 \times 45 = ₹ 1575$$

Clearly selling price > cost price so it is a profit.

$$\begin{aligned}\text{Profit} &= \text{selling price} - \text{cost price} \\ &= ₹ 1575 - ₹ 1500 = ₹ 75\end{aligned}$$

On cost price of ₹ 1500 profit is ₹ 75

The profit on the cost price of ₹ 100 is the percentage of profit.

$$\text{Therefore, profit percent} = \frac{75}{1500} \times 100 = 5\%$$

Example 7: Malik sells two tables for ₹ 3000 each. He gains 20% on one table and on the other he loses 20%. Find his gain or loss percent on the whole transaction.

Solution:

For first table

Selling Price = ₹ 3000

Profit percent = 20%

profit percent means increased percent on cost price

Selling price is ₹ 120 when Cost price is ₹ 100

When selling price is ₹ 3000 what will be the cost price?

$$\text{Cost price} = ₹ 100 \times \frac{3000}{120} = ₹ 2500$$

For second table

Selling price = ₹ 3000

Loss percent = 20%

Loss percent means decreased percent on cost price

Selling price is ₹ 80 when cost price is ₹ 100

When selling price is ₹ 3000 what will be the cost price?

$$\text{Cost price} = ₹ 100 \times \frac{3000}{80} = ₹ 3750$$

Total cost price on two tables = ₹ 2500 + ₹ 3750 = ₹ 6250

Total selling price on two tables = ₹ 3000 + ₹ 3000 = ₹ 6000.

Since cost price > selling price. So there is a loss

Loss = cost price – selling price = ₹ 6250 – ₹ 6000 = ₹ 250

On cost price of ₹ 6250 loss is ₹ 250

On cost price of ₹ 100 what will be the loss?

$$\text{Loss percent} = 250 \times \frac{100}{6250} = 4\%$$

So there is a loss of 4% on the whole transaction.

**Think, Discuss and Write**

A shop keeper sold two TV sets at ₹ 9,900 each. He sold one at a profit of 10% and the other at a loss of 10%. On the whole whether he gets profit or loss. If so what is its percentage?

5.5 Sales Tax / Value Added Tax (VAT)

Government collects taxes on every sale. This is called VAT. Shop keepers collect this from the customers and pay it to the Government. Why does the government charge taxes like this? Do you know? With the taxes collected, government does several welfare activities.

Sales tax is levied on the sale of movable goods. VAT is imposed on goods only and not services and it has replaced sales tax. The percent of VAT is different for different items. In general, on the essential commodities, there is an exemption from VAT, 1% on bullion and precious stones, 5% on industrial inputs and capital goods and items of mass consumption. For all other items it is 14.5%. (Rates were fixed by Government of India in 2012).

VAT is charged on the Selling Price of an item and will be included in the bill. VAT is an increase percent of selling price. Observe the following VAT added bill.

Ganapati went to a medical shop to buy medicines for his mother. The shop keeper gave the bill which appears like this. Bill amount was ₹ 372.18. It contains 5% VAT.

(i) Find the bill amount before VAT was added.

Tax Invoice No. : 2012?301549007214		Date : 15-09-2012 20:48:31						
Name : Ganpathi	Age : 35	Gender : M	Doc: Dr. Aiman Do.Reg. No. :					
		Cus.ID:20121301549000617 Add: Sainathpura)						
S. Product	Mfgr	Sch	Batch	Exp.	MRP.	Rate	Qty	Amount
1 BETATROP TAB	SUN	H	BSK4198	12-14	5.9	5.9	60	318.60
2. ECOSPRIN 150 MG TAB	USV	H	04004652	05-14	0.4242857	0.38	42	16.04
3. LASIX 40 MG TAB	AVENTIS	H	0212016	03-16	0.44733334	0.40	15	6.04
4. ELDERVIT PLUS CAD	ELDER	C	SE0022008	08-13	2.3333333	2.10	15	31.5
Amount saved : 41.35		VAT ON ₹ 354.45 @ 5% = 17.72				Total : 372.18		
						Rounded Total : 372.00		

From the bill copy it is clear that the actual bill amount = ₹ 354.45 and VAT @ 5% = ₹17.72

Example 8: The cost of a pair of shoes is ₹ 450. The sales tax charged was 6%. Find the bill amount.

Solution: On ₹ 100 the sales tax paid is ₹ 6.

On ₹ 450 the tax to be paid is?

$$\text{Sales tax paid} = ₹ \frac{6}{100} \times 450 = ₹ 27.$$

$$\text{Bill amount} = \text{Cost of item} + \text{sales tax} = ₹ 450 + ₹ 27 = ₹ 477.$$

5.6 Goods and Service Tax (GST)

It is a single indirect tax on the supply of goods and services. It was introduced in July 2017 by abolishing a variety of taxes such as sales tax and excise prevailed in India. Under GST, tax is imposed on the basis of value addition at each stage of the movement of goods and services.

Different slabs of tax rates such as 3%, 5%, 12%, 18% and 28% are imposed on almost all the goods and services. This slab is same throughout the country. In prescribed slabs 50% of the amount goes to central government and the other 50% goes to state government.

Example:9 Vignesh went to a general store to buy some items for his family. The shop keeper gave the bill which appears as follows.

Bill amount was ₹ 2200. It contains 18% GST. Find the bill amount before GST was added and Also find CGST and SGST share amount in GST?

Name of Item	Quantity	Rate Per kg	Amount (₹)
Rice	10 kg	100	1000
Washing Powder	3 kg	100	300
Pulses	6 kg	150	900
Total			2200

Solution: Bill amount including GST = ₹ 2200

Value of GST = 18%

$$\text{Value of GST in the bill amount} = 2200 \times \frac{18}{100} = ₹ 396$$

$$\text{Total Bill amount before GST} = ₹ 2200 - ₹ 396 = ₹ 1804$$

The percentage of CGST in GST = 50%

The percentage of SGST in GST = 50%

$$\text{The value of CGST in GST amount} = 396 \times \frac{50}{100} = ₹ 198$$

$$\text{Similarly the value of SGST in GST amount} = 396 \times \frac{50}{100} = ₹ 198$$

Example: 10 The cost of a pair of shoes is ₹1000. The GST charged was 5%. Find the bill amount.

Solution: On ₹ 100 the GST paid is ₹ 5.

On ₹ 1000 the tax to be paid is?

$$\text{GST tax paid} = ₹ \frac{5}{100} \times 1000 = ₹ 50$$

$$\text{Bill amount} = \text{Cost of item} + \text{GST} = ₹ 1000 + ₹ 50 = ₹ 1050.$$



Exercise - 5.2

- In the year 2012, it was estimated that there were 36.4 crore Internet users worldwide. In the next ten years, that number will be increased by 125%. Estimate the number of Internet users worldwide in 2022.

2. An owner increases the rent of his house by 5% at the end of each year. If currently its rent is ₹ 2500 per month, how much will be the rent after 2 years?
3. On Monday, the value of a company's shares was ₹ 7.50. The price increased by 6% on Tuesday, decreased by 1.5% on Wednesday, and decreased by 2% on Thursday. Find the value of each share when trade opened on Friday.
4. With most of the Xerox machines, you can reduce or enlarge your original by entering a percentage for the copy. Reshma wanted to enlarge a 2 cm by 4 cm drawing. She set the Xerox machine for 150% and copied her drawing. What will be the dimensions of the copy of the drawing be?
5. The printed price of a book is ₹ 150. And discount is 15%. Find the actual amount to be paid.
6. The marked price of a gift item is ₹ 176 and sold it for ₹ 165. Find the discount percent.
7. A shop keeper purchased 200 bulbs for ₹ 10 each. However 5 bulbs were fused and put them into scrap. The remaining were sold at ₹ 12 each. Find the gain or loss percent.
8. Complete the following table with appropriate entries (Wherever possible)

S. No.	Cost Price (C.P.)	Expenses	Selling Price(S.P.)	Profit	Loss	Profit Percentage	Loss Percentage
1	₹ 750	₹ 50		₹ 80			
2	₹ 4500	₹ 500			₹ 1,000		
3	₹ 46,000	₹ 4000	₹ 60,000				
4	₹ 300	₹ 50				12%	
5	₹ 330	₹ 20					10%

9. A table was sold for ₹ 2,142 at a gain of 5%. At what price should it be sold to gain 10%.
10. Gopi sold a watch to Ibrahim at 12% gain and Ibrahim sold it to John at a loss of 5%. If John paid ₹ 1,330, then find how much did Gopi sold it?
11. Madhu and Kavitha purchased a new house for ₹ 3,20,000. Due to some economic problems they sold the house for ₹ 2, 80,000.
Find (a) The loss incurred (b) the loss percentage.
12. A pre-owned car show-room owner bought a second hand car for ₹ 1,50,000. He spent ₹ 20,000 on repairs and painting, then sold it for ₹ 2,00,000. Find whether he gets profit or loss. If so, what percent?
13. Lalitha took a parcel from a hotel to celebrate her birthday with her friends. It was billed with ₹ 1,450 including 5% VAT. Lalitha asked for some discount, the hotel owner gave 8% discount on the bill amount. Now find the actual amount that Lalitha has to pay to the hotel owner.

14. If GST is included in the price, find the actual price of each of the following.

S. No.	Item	GST%	Bill amount(in ₹)	Original Price(in ₹)
(i)	Diamond	3%	₹ 10,300	
(ii)	Pressure cooker	12%	₹ 3,360	
(iii)	Face powder	28%	₹ 256	

15. A Cellphone Company fixed the price of a cellphone as ₹ 4500. A dealer purchased a cell phone on which he paid 12% GST. additionally. How much did the dealer paid as GST? What is the purchase price of Cellphone?
16. A Super-Bazar prices an item in rupees and paise so that when 4% sales tax is added, no rounding is necessary because the result is exactly in 'n' rupees, where 'n' is a positive integer. Find the smallest value of 'n'.

5.7 Compound Interest

Interest is the money paid by bank or post office when money is deposited with them. Also it is paid by the borrower to the person or organisation that lent money. Interest is the extra amount paid on principal amount with a year marked percent.

But how do we calculate this interest? When the interest is calculated uniformly on the original principal throughout the loan period, what do you call such interest calculation? Yes! It is called simple interest. It is also an increase percent on the Principal. Let us see an example to understand this.

Example 11: A sum of ₹ 2500 is borrowed at a rate of 12% per annum for 3 years. Find the simple interest on this sum and also the amount to be paid at the end of 3 years.

Solution: Here P = ₹ 2500, T = 3 years, R = 12%

$$\begin{aligned} \text{As } I &= \frac{PTR}{100} \\ &= \frac{2500 \times 3 \times 12}{100} \end{aligned}$$

Interest for 3 years = ₹ 900.

Amount to be paid at the end of 3 years = Principal + Interest

$$= ₹ 2500 + ₹ 900 = ₹ 3400.$$

We see that Amount = Principal + Interest = $P + \frac{P \times T \times R}{100} = P \left(1 + \frac{T \times R}{100} \right)$

When T = 1 year, Amount A = $P \left(1 + \frac{R}{100} \right)$



Try These

Complete the table

S. No.	Principal (P) in ₹	Time (T) in years	Rate of interest p.a. (R) in %	Interest (I) = $\frac{P \times T \times R}{100}$ in ₹
1	3000	3	6	
2		2	5	50
3	1875		12	675
4	1080	2.5		90

Ramesh borrowed an amount of ₹100 at the rate of 10% p.a. (per annum) from Sreenu as hand loan. After 2 years he went to Sreenu to repay his debt. Ramesh gave an amount of ₹120 and Sreenu said he has to pay ₹1 more. To find out the difference in their calculations, both of them did their calculations on a paper as shown below.

Ramesh's method			Sreenu's method		
1 st year	Principal amount	₹ 100	1 st year	Principal amount	₹ 100
	Interest @ 10%	₹ 10		Interest @ 10%	₹ 10
	Total amount	₹ 110		Total amount	₹ 110
2 nd year	Principal	₹ 100	2 nd year	Principal	₹ 110
	Interest @ 10%	₹ 10		Interest @ 10%	₹ 11
	Amount to be paid at the end of 2 nd year	= Principal + Interest on 1 st year + Interest on 2 nd year = 100+10+10 = ₹120		Amount to be paid at the end of 2 nd year	₹ 121

The difference in the two methods is ₹1. Why there is a difference in both the methods? You can easily observe that while doing the calculation of interest for 2nd year Ramesh took principal amount as ₹100 whereas for doing the same Sreenu took ₹110. We call the interest calculated by Ramesh as Simple interest. Do you know what we call the interest calculated by Sreenu? In case of Sreenu, the interest is calculated on amount accumulated till then. It is called compound interest.. So Compound interest allows you to earn interest on interest. Which type of interest would you prefer and why ?

5.8 Deducing a formula for Compound interest

In the above example, we observe that Sreenu calculated compound interest. If it is a year or two, it is easy to do the calculations like that. But if we have more than two years, should we calculate in the same way? Is there a shorter way for finding compound interest? Let us consider an example and try to find out.

When $t = 1$ year Amount $(A) = P \left(1 + \frac{R}{100} \right)$ with simple interest

Let $P_1 = ₹ 10,000$ and $R = 12\%$ per annum

Sreenu's method			Generalisation of same method		
1 st year	Principal P_1	₹ 10,000	1 st year	Principal	P_1
	Amount A_1	$10000 \left(1 + \frac{12}{100} \right)$ $= 10000 \left(\frac{112}{100} \right)$ $= ₹ 11,200$		Amount A_1	$A_1 = P_1 \left(1 + \frac{R}{100} \right)$
2 nd year	Principal P_2	₹ 11,200	2 nd year	Principal	$P_2 = P_1 \left(1 + \frac{R}{100} \right)$
	Amount A_2	$11200 \left(1 + \frac{12}{100} \right)$ $= 11200 \left(\frac{112}{100} \right)$ $= ₹ 12,544$		Amount A_2	$A_2 = P_2 \left(1 + \frac{R}{100} \right)$ $= P_1 \left(1 + \frac{R}{100} \right) \left(1 + \frac{R}{100} \right)$ $= P_1 \left(1 + \frac{R}{100} \right)^2$

Proceeding in this way the amount at the end of 'n' years will be $A_n = P_1 \left(1 + \frac{R}{100} \right)^n$

Thus the amount on compound interest $A = P \left(1 + \frac{R}{100} \right)^n$

But by using this we get only the amount to be paid at the end of 'n' years. How do we get compound interest? Yes it is so simple. From the final amount subtract principal to get compound interest.

$$\therefore C.I = P \left(1 + \frac{R}{100} \right)^n - P$$

So what is the difference between simple interest and compound interest? Simple interest remains the same every year. But compound interest increases over time.

Example:12 What will be the amount and compound interest, if ₹ 5000 is invested at 8% per annum 2 years?

Solution: $P = ₹ 5000$; $R = 8\%$ and $n = 2$ years

$$\begin{aligned}A &= P \left(1 + \frac{R}{100}\right)^n \\&= 5000 \left(1 + \frac{8}{100}\right)^2 \\&= 5000 \times \frac{108}{100} \times \frac{108}{100} = ₹ 5832.\end{aligned}$$

$$\begin{aligned}\text{Interest earned} &= \text{Amount} - \text{Principal} \\&= ₹ 5832 - ₹ 5000 \\&= ₹ 832\end{aligned}$$



Do These

1. How much compound interest is earned by investing ₹ 20 000 for 6 years at 5% per annum compounded annually. ?
2. Find compound interest on ₹ 12600 for 2 years at 10% per annum compounded annually.

5.9 Interest compounded annually or Half yearly (Semi Annually)

You may observe that in the previous problems we are using the word ‘compounded’ annually. Does it have any significance? Yes, it has. Because we can also have interest rates compounded half yearly or quarterly.

When interest is not compounded annually what do we call the time period after which interest is added to principal? It is called **Conversion period**. When interest is compounded half yearly, there are two conversion periods in a year each after 6 months. In such a case, the interest will be half of the annual rate and the number of times that interest is compounded is twice the number of years.

Example:13 Calculate Compound interest on ₹ 1000 over a period of 1 year at 10% per annum if interest is compounded half yearly.

Solution: As interest is compounded half yearly, so there will be 2 conversion periods in a year.

$$\text{So } n=2$$

$$\text{Rate of interest for 6 months rate} = \frac{1}{2} \times 10\% = 5\%$$

$$A = P \left(1 + \frac{R}{100} \right)^n$$

$$A = 1000 \left(1 + \frac{5}{100} \right)^2$$

$$= 1000 \left(\frac{105}{100} \right)^2$$

$$= ₹ 1102.50$$

$$\text{Compound interest} = A - P = 1102.50 - 1000 = ₹ 102.50$$



Do These

Find the number of conversion times the interest is compounded and rate for each

1. A sum taken for $1\frac{1}{2}$ years at 8% per annum is compounded half yearly.
2. A sum taken for 2 years at 4% per annum compounded half yearly.



Think, Discuss and Write

What will happen if interest is compounded quarterly? How many conversion periods will be there? What about the quarter year rate- how much will it be of the annual rate? Discuss with your friends.

Example 14: What amount is to be repaid on a loan of ₹ 12000 for $1\frac{1}{2}$ year at 10% per annum if interest is compounded half yearly.

Solution: As interest is compounded half yearly, so number of conversion periods in

$1\frac{1}{2}$ years is 3, So $n = 3$

rate for half year = $\frac{1}{2} \times 10\% = 5\%$

$$A = P \left(1 + \frac{R}{100} \right)^n$$

$$A = 12000 \left(1 + \frac{5}{100} \right)^3$$

$$= 12000 \left(\frac{105}{100} \right)^3$$

$$= ₹ 13891.50$$

$$\begin{aligned}\text{Compound interest} &= A - P \\ &= 13891.50 - 12000 \\ &= ₹ 1891.50\end{aligned}$$

Example:15 Yadaiah for his family needs borrowed ₹ 5120 at $12\frac{1}{2}\%$ per annum compounded annually. How much amount he has to pay to clear the debt at the end of two year nine months? Also find total how much interest he has paid?

Solution: Reshma tried to solve the problem like this
She first converted the time in years.

$$2 \text{ year } 9 \text{ months} = 2\frac{9}{12} \text{ year} = 2\frac{3}{4} \text{ years}$$

She tried to substitute this in the known formula $A = 5120\left(1 + \frac{25}{200}\right)^{2\frac{3}{4}}$

Now she was stuck. She asked her teacher, how would she find a power which is fractional? The teacher gave her a hint. First find the amount for the whole part.

Then use this as principal to get simple interest for $\frac{3}{4}$ year

$$\text{So } A = P\left(1 + \frac{R}{100}\right)^n$$

$$A = 5120\left(1 + \frac{25}{200}\right)^2$$

$$= 5120\left(\frac{225}{200}\right)^2$$

$$= ₹ 6480$$

$$\text{Interest for remaining 9 months} = 6480 \times \frac{25}{2} \times \frac{3}{4} \times \frac{1}{100} = ₹ 607.50.$$

$$\begin{aligned}\text{So Yadaiah has to pay at the end of 2 year 9 months} \\ &= 6480 + 607.50 = ₹ 7087.50\end{aligned}$$

$$\text{So total compound interest} = 7087.50 - 5120 = ₹ 1967.50$$

5.10 Application of Compound

Where do we use this compound interest formula? Not only for calculating interest, but it can also be used in different cases. For example,

- Increase (or decrease) in population
- The growth of bacteria if the rate of growth is known
- The value of an item, if its price increases (or decreases) in the intermediate years.

Example 16: The population of a village is 6250. It is found that the rate of increase in population is 8% per annum. Find the population after 2 years.

Solution: Here $P = 6250$ $R = 8\%$ $T = 2$ years

$$\begin{aligned} \text{Population after 2 years } A &= P \left(1 + \frac{R}{100} \right)^n \\ A &= 6250 \left(1 + \frac{8}{100} \right)^2 \\ &= 6250 \left(\frac{108}{100} \right)^2 \\ &= 7290 \end{aligned}$$

Example 17: A rubber ball is dropped from a certain height. It is found to rebound only 90% of its previous height. If it is dropped from the top of a 25m tall building, to what height would it raise after bouncing on the ground two times.

Solution: The ball rises to a height of 90% at the first bounce. So at each bounce the loss in height is 10%

So taking $R = -10\%$ the problem can be solved.

$P = 25$ m and $n = 2$

The height to which it raises after bouncing two times on the ground

$$\begin{aligned} A &= P \left(1 + \frac{R}{100} \right)^n \\ A &= 25 \left(1 - \frac{10}{100} \right)^2 \\ &= 25 \left(\frac{90}{100} \right)^2 \\ &= 20.25 \text{ m} \end{aligned}$$



Exercise - 5.3

1. Sudhakar borrows ₹ 15000 from a bank to renovate his house. He borrows the money at 9% p.a. simple interest over 8 years. What are his monthly repayments?
2. A TV was bought at a price of ₹ 21000. After 1 year the value of the TV was depreciated by 5% (Depreciation means reduction of the value due to use and age of the item). Find the value of the TV after 1 year.

3. Find the amount and the compound interest on ₹ 8000 at 5% per annum, for 2 years compounded annually.
4. Find the amount and the compound interest on ₹ 6500 for 2 years, compounded annually, the rate of interest being 5% per annum during the first year and 6% per annum during the second year.
5. Prathibha borrows ₹ 47000 from a finance company to buy her first car. The rate of simple interest is 17% and she borrows the money over a 5 year period. Find: (a) How much amount Prathibha should repay the finance company at the end of five years. (b) her equal monthly repayments.
6. The population of Hyderabad was 68,09,000 in the year 2011. If it increases at the rate of 4.7% per annum. What will be the population at the end of the year 2015.
7. Find Compound interest paid when a sum of ₹ 10000 is invested for 1 year and 3 months at $8\frac{1}{2}$ % per annum compounded annually.
8. Arif took a loan of ₹ 80,000 from a bank. If the rate of interest is 10% per annum, find the difference in amounts he would be paying after $1\frac{1}{2}$ years, if the interest is compounded annually and compounded half yearly.
9. I borrowed ₹ 12000 from Prasad at 6% per annum simple interest for 2 years. Had I borrowed this sum at 6% per annum compounded annually, what extra amount would I have to pay?
10. In a laboratory the count of bacteria in a certain experiment was increasing at the rate of 2.5% per hour. Find the bacteria at the end of 2 hours if the count was initially 5, 06,000
11. Kamala borrowed ₹ 26400 from a bank to buy a scooter at a rate of 15% per annum compounded yearly. What amount will she pay at the end of 2 years and 4 months to clear the loan?
12. Bharathi borrows an amount of ₹ 12500 at 12% per annum for 3 years at a simple interest and Madhuri borrows the same amount for the same time period at 10% per annum, compounded annually. Who pays more interest and by how much?
13. Machinery worth ₹ 10000 depreciated by 5%. Find its value after 1 year.
- 14.. Find the population of a city after 2 years which is at present 12 lakh, if the rate of increase is 4%.
15. Calculate compound interest on ₹ 1000 over a period of 1 year at 10% per annum, if interest is compounded quarterly?



What we have discussed



- Two simple ratios are expressed like a single ratio as the ratio of product of antecedents to product of consequents and we call it Compound ratio of the given two simple ratios. $a:b$ and $c:d$ are any two ratios, then their compound ratio is $\frac{a}{b} \times \frac{c}{d} = \frac{ac}{bd}$ i.e. $ac : bd$.
- A percentage (%) compares a number to 100. The word percent means “per every hundred” or “out of every hundred”. $100\% = \frac{100}{100}$ it is also a fraction with denominator 100.
- Discount is a decrease percent of marked price.
Price reduction is called Rebate or discount. It is calculated on marked price or List Price.
- Profit or loss is always calculated on cost price. Profit is an example of increase percent of cost price and loss is an example of decrease percent of cost price.
- VAT will be charged on the Selling Price of an item and will be included in the bill.
VAT is an increase percent on Selling Price.
- Simple interest is an increase percent on the Principal
- Simple interest (I) = $\frac{P \times T \times R}{100}$ where P = principal T = Time in years R = Rate of interest.
- Amount = Principal + Interest = $P + \frac{P \times T \times R}{100} = P \left(1 + \frac{T \times R}{100} \right)$
- Compound interest allows you to earn interest on interest.
- Amount at the end of ‘n’ years using compound interest is $A = P \left(1 + \frac{R}{100} \right)^n$
- The time period after which interest is added to principal is called conversion period. When interest is compounded half yearly, there are two conversion periods in a year, each after 6 months. In such a case, half year rate will be half of the annual rate.



Do you Know?

In ancient Greece, artists and architects believed there was a particular rectangular shape that looked very pleasing to the eye. For rectangles of this shape, the ratio of long side to the short side is roughly **1.615:1**. This ratio is very close to what is known as Golden ratio. The famous Greek temple the Parthenon, made entirely of white marble in the 5th century C.E. was built according to the Golden Ratio.



The Taj Mahal in India is also an example of architecture for Golden ratio.

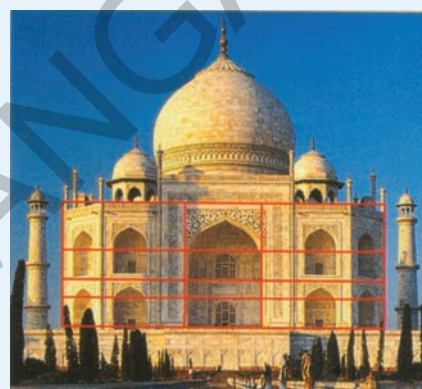

Addition of Equal Ratios

1. What is the sum of $\frac{1}{2}, \frac{2}{4}, \frac{3}{6}, \frac{4}{8}, \dots, \frac{100}{200}$?

can we add like this?

$$\begin{aligned} \frac{1}{2} = \frac{2}{4} = \frac{3}{6} = \frac{4}{8} = \dots = \frac{100}{200} &= \frac{1+2+3+4+\dots+100}{2+4+6+8+\dots+200} \\ &= \frac{5050}{2 \times 5050} = \frac{1}{2} \end{aligned}$$

If $\frac{p_1}{q_1} = \frac{p_2}{q_2} = \frac{p_3}{q_3} = \dots = \frac{p_n}{q_n}$ then $\frac{p_1 + p_2 + p_3 + \dots + p_n}{q_1 + q_2 + q_3 + \dots + q_n} = \frac{p_1}{q_1}$

2. $\frac{a}{b} = \frac{c}{d}$ iff $\frac{a+b}{b} = \frac{c+d}{d}$ ($b, d > 0$)

$$\frac{1}{2} = \frac{3}{6} \text{ iff } \frac{1+2}{2} = \frac{3+6}{6}$$

$$\frac{3}{2} = \frac{9}{6} \text{ again this can be written as } \frac{5}{2} = \frac{15}{6} \dots$$





B3K2Z1

6.0 Introduction

Let us make square shapes using unit squares and observe the number of unit squares used.

A unit square is a square whose side is 1 unit

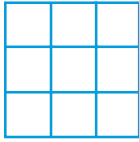
S.No.	Figure	Length of the side in units	No. of unit squares used
1		1	1
2		2	4
3		3	9

Similarly make next two squares.

Can you guess how many unit squares are required for making a square whose side is 6 units? From the above observations we could make square shapes with 1, 4, 9, 16, 25 ... unit squares.

These numbers 1, 4, 9, 16, 25, ... can be expressed as

$$1 = 1 \times 1 = 1^2$$

$$4 = 2 \times 2 = 2^2$$

$$9 = 3 \times 3 = 3^2$$

$$16 = 4 \times 4 = 4^2$$

$$25 = \dots \times \dots = \dots$$

$$36 = \dots \times \dots = \dots$$

.....

.....

$$m = n \times n = n^2 \text{ where } m, n \text{ are integers.}$$

Observe the pattern of factors in each case

You might have observed in the given pattern that the numbers are expressed as the product of two equal factors. Such numbers are called perfect squares.

Observe the following perfect square numbers

Ex: (i) $9 = 3 \times 3$ (ii) $49 = 7 \times 7$ (iii) $1.44 = 1.2 \times 1.2$

(iv) $2.25 = 1.5 \times 1.5$ (v) $\frac{9}{16} = \frac{3}{4} \times \frac{3}{4}$ (vi) $\frac{4}{12.25} = \frac{2}{3.5} \times \frac{2}{3.5}$

In case (i) and (ii) we have noticed the perfect square numbers 9 and 49 are integers. The general form of such perfect square numbers is $m = n \times n$ (where m and n are integers).

In case (iii), (iv) and (v), (vi) the perfect square numbers are not integers. Hence, they are not square numbers.

If an integer 'm' is expressed as n^2 where n is an integer then 'm' is a square number or 'm' is a square of 'n'.

Perfect square : A rational number that is equal to the square of another rational number.

Square number : An integer that is a square of another integer. Thus

“All square numbers are perfect squares” but all perfect squares may not be square numbers.

Ex: 2.25 is a perfect square number because it can be expressed as $2.25 = (1.5)^2 = 1.5 \times 1.5$, it is not square of an integer. Therefore, it is not a square number.

Is 42 a square number?

We know that $6^2 = 36$ and $7^2 = 49$, if 42 is a square number it must be the square of an integer. Which should be between 6 and 7. But there is no such integer between 6 and 7.

Therefore 42 is not a square number.

Observe the perfect squares in the given table

①	2	3	④	5	6	7	8	⑨	10
11	12	13	14	15	⑬	17	18	19	20
21	22	23	24	⑮	26	27	28	29	30
31	32	33	34	35	⑰	37	38	39	40
41	42	43	44	45	46	47	48	⑲	50
51	52	53	54	55	56	57	58	59	60
61	62	63	⑳	65	66	67	68	69	70
71	72	73	74	75	76	77	78	79	80
⑲	82	83	84	85	86	87	88	89	90
91	92	93	94	95	96	97	98	99	⑳

Are there any other square numbers that exist other than the numbers shown in the table.



Do This

- Find the perfect squares between (i) 100 and 150 (ii) 150 and 200
- Is 56 a perfect square? Give reasons?

6.1 Properties of square numbers

Observe and fill the following table.

Number	Square
1	1
2	4
3	9
4	16
5	25
6
7	49
8	64
.....	81
10	100

Number	Square
11	121
12	144
13
14	196
15	225
16
17	289
18	324
19	361
20	400

Number	Square
21	441
22
23	529
.....	576
25	625
.....
.....
.....
.....
.....

Observe the digits in the units place of the square numbers in the above table. Do you observe all these numbers end with 0, 1, 4, 5, 6 or 9 at units place, none of these end with 2, 3, 7 or 8 at units places?

“The numbers that have 2, 3, 7 or 8 in the units place are not perfect squares.”

Can we say that all numbers end with 0, 1, 4, 5, 6 or 9, at unit place are square numbers? Think about it.



Try These

- Guess and give reason which of the following numbers are perfect squares. Verify from the above table.
(i) 84 (ii) 108 (iii) 271 (iv) 240 (v) 529

Write the squares of 1, 9, 11, 19, 21

Have you noticed any relationship between the units digit of numbers and their squares?

We observe that if a number has 1 or 9 in the units place, then the units digit in its square number is only 1.

If a number has 4 or 6 in the units place, then the units digit in its square is always 6

Similarly, explore the units digit of squares of numbers ending with 0,2,3, 5, 7 and 8.



Try These

- Which of the following have 1 in its units place?
(i) 126^2 (ii) 179^2 (iii) 281^2 (iv) 363^2
- Which of the following have 6 in the units place?
(i) 116^2 (ii) 228^2 (iii) 324^2 (iv) 363^2



Think, Discuss and Write

Vaishnavi claims that the square of even numbers are even and that of odd are odd. Do you agree with her? Justify.

Observe and complete the table.

Numbers	No. of digits in its square	
	(Minimum)	(Maximum)
1-9	1	2
10-99	4
100-999	5
1009-9999	7	8
n digits



Try These

- Guess, How many digits are there in the squares of
(i) 72 (ii) 103 (iii) 1000

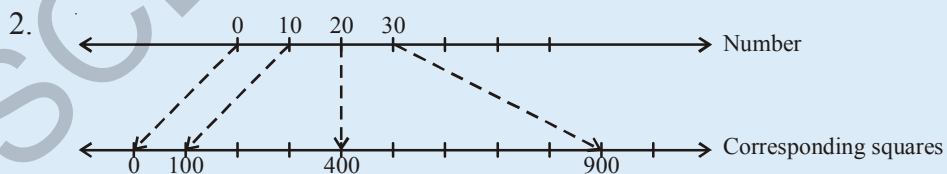

27 lies between 20 and 30

27^2 lies between 20^2 and 30^2

Now find what would be 27^2 from the following perfect squares.

- (i) 329 (ii) 525 (iii) 529 (iv) 729

6.2 Interesting patterns in square

1. Observe the following pattern and complete.



$$1 = 1^2$$

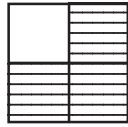

$$1+3 = 4 = 2^2$$

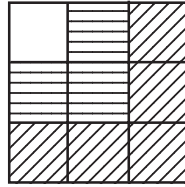

$$1 + 3 + 5 = 9 = 3^2$$

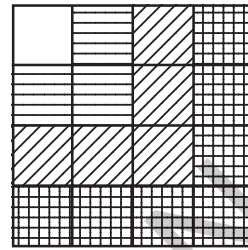

$$1+3+5+7 = 16 = 4^2$$

$$1 = 1 = 1^2$$

$$1 + 3 = 4 = 2^2$$

$$1 + 3 + 5 = 9 = 3^2$$

$$1 + 3 + 5 + 7 = 16 = 4^2$$

$$1 + 3 + 5 + 7 + 9 = 25 = 5^2$$

$$1 + 3 + 5 + 7 + 9 + 11 = \dots = (\quad)^2$$

$$1 + 3 + 5 + 7 + 9 + 11 + 13 = \dots = (\quad)^2$$

From this, we can generalize that the sum of first 'n' odd natural numbers is equal to 'n²'.

2. Observe the following pattern and find the missing numbers

$$(11)^2 = 121$$

$$(101)^2 = 10201$$

$$(1001)^2 = 1002001$$

$$(10001)^2 = \dots$$

$$(1000001)^2 = \dots$$

3. Observe the pattern and complete it

$$1^2 = 1$$

$$11^2 = 121$$

$$111^2 = 12321$$

$$1111^2 = 1234321$$

$$11111^2 = \dots$$

$$111111^2 = \dots$$

A palindrome is a word; phrase, a sentence or a numerical that reads the same forward or backward.

Ex: NOON, MADAM, 15651

These numbers are called palindromic numbers or numerical palindrome.

4. From the following pattern find the missing numbers

$$1^2 + 2^2 + 2^2 = 3^2$$

$$2^2 + 3^2 + 6^2 = 7^2$$

$$3^2 + 4^2 + 12^2 = 13^2$$

$$4^2 + 5^2 + ()^2 = 21^2$$

$$5^2 + ()^2 + 30^2 = ()^2$$

$$6^2 + 7^2 + ()^2 = ()^2$$

Observe the sum of the squares.

Do you find any relation between the bases of squares ?

How the base of the third number is related to the base of first and second square numbers?

How the base of the resultant square number is related to the base of the third square number?

5. Find the missing numbers using the given pattern

$$3^2 = 9 = 4 + 5 \quad \left(\frac{3^2 - 1}{2} + \frac{3^2 + 1}{2} \right)$$

$$5^2 = 25 = 12 + 13 \quad \left(\frac{5^2 - 1}{2} + \frac{5^2 + 1}{2} \right)$$

$$7^2 = 49 = 24 + 25 \quad (\quad + \quad)$$

$$11^2 = 121 = \dots + \dots \quad \left(\frac{11^2 - 1}{2} + \frac{11^2 + 1}{2} \right)$$

$$15^2 = 225 = \dots + \dots \quad (\quad + \quad)$$

From this, we can conclude that the square of any odd number say n can be expressed as the

sum of two consecutive numbers as $\left(\frac{n^2 - 1}{2} + \frac{n^2 + 1}{2} \right)$

6. Numbers between successive square numbers

Observe and complete the following table.

Successive squares	Numbers between the successive square numbers	Relation
$1^2 = 1; 2^2 = 4$	2, 3 (2 numbers lies between 1 and 4)	$2 \times \text{Base of first number } 1, (2 \times 1 = 2)$
$2^2 = 4; 3^2 = 9$	5, 6, 7, 8 (4 numbers lies between 4 and 9)	$2 \times \text{Base of first number } 2, (2 \times 2 = 4)$
$3^2 = 9; 4^2 = 16$	10, 11, 12, 13, 14, 15 (6 numbers lies between 9 and 16)	$2 \times \text{Base of first number } 3, (2 \times 3 = 6)$
$4^2 = 16; 5^2 = 25$	$2 \times \text{Base of first number } 4, (2 \times 4 = 8)$
$5^2 = 25; 6^2 = 36$
.....

From the above table have you observed any relation between the successive square numbers and numbers between them?

With the help of the above table, try to find the number of non square numbers between n^2 and $(n + 1)^2$.

There are '2n' non square numbers between n^2 and $(n + 1)^2$.



Do This

1. How many non perfect square numbers are there between 9^2 and 10^2 ?
2. How many non perfect square numbers are there between 15^2 and 16^2 ?



Try These

Rehan says there are 37 non square numbers between 9^2 and 11^2 . Is he right? Give your reason.



Exercise - 6.1

1. What will be the units digit of the square of the following numbers?
(i) 39 (ii) 297 (iii) 5125 (iv) 7286 (v) 8742
2. Which of the following numbers are perfect squares?
(i) 121 (ii) 136 (iii) 256 (iv) 321 (v) 600
3. The following numbers are not perfect squares. Give reasons?
(i) 257 (ii) 4592 (iii) 2433 (iv) 5050 (v) 6098
4. Find whether the square of the following numbers are even or odd?
(i) 431 (ii) 2826 (iii) 8204 (iv) 17779 (v) 99998
5. How many integers lie between the square of the following numbers.
(i) 25; 26 (ii) 56; 57 (iii) 107;108
6. Without adding, find the sum of the following numbers
(i) $1 + 3 + 5 + 7 + 9 =$
(ii) $1 + 3 + 5 + 7 + 9 + 11 + 13 + 15 + 17 =$
(iii) $1 + 3 + 5 + 7 + 9 + 11 + 13 + 15 + 17 + 19 + 21 + 23 + 25 =$

6.3 Pythagorean triplets

Consider the following

- (i) $3^2 + 4^2 = 9 + 16 = 25 = 5^2$
 (ii) $5^2 + 12^2 = 25 + 144 = 169 = 13^2$

The numbers (3, 4, 5) and (5, 12, 13) are some examples for Pythagorean triplets.

Generally a, b, c are three positive integers. If $a^2 + b^2 = c^2$ then (a, b, c) are said to be pythagorean triplet.

If there are no common factors other than '1' among a,b,c then the triplet (a,b,c) is called primitive triplet.



Do This

- Check whether the following numbers form Pythagorean triplet
 (i) 2, 3, 4 (ii) 6, 8, 10 (iii) 9, 10, 11 (iv) 8, 15, 17
- Take a Pythagorean triplet. Write their multiples. Check whether these multiples form a Pythagorean triplet.

6.4 Square Roots

Observe the following squares and complete the table.

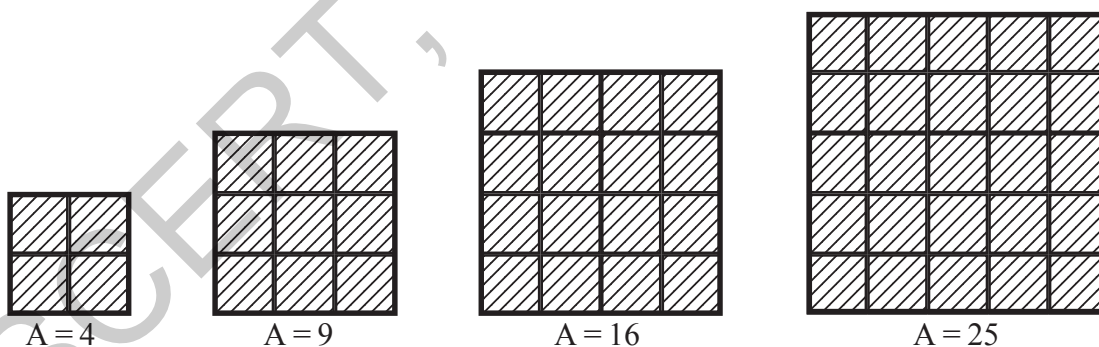

Area of the square (in cm^2) (A)	Side of the square (in cm) (S)
$4 = 2 \times 2$	2
$9 = 3 \times 3$	3
$16 = 4 \times 4$	_____
$25 = 5 \times 5$	_____

The number of unit squares in a row / column represents the side of a square.

Do you find any relation between the area of the square and its side?

We know that the area of the square = side \times side = side²

If the area of a square is 169 cm². What could be the side of the square?

Let us assume that the length of the side be 'x' cm.

$$\Rightarrow 169 = x^2$$

To find the length of the side, it is necessary to find a number whose square is 169.

We know that $169 = 13^2$. Then the length of the side = 13 cm.

Therefore, if a square number is expressed, as the product of two equal factors, then one of the factors is called the square root of that square number. Thus, the square root of 169 is 13. It can be expressed as $\sqrt{169} = 13$ (symbol used for square root is $\sqrt{\quad}$). Thus it is the inverse operation of squaring.

Example 1: $3^2 = 9$ therefore square root of 9 is 3 ($\sqrt{9} = 3$)

$4^2 = 16$ therefore square root of 16 is 4 ($\sqrt{16} = 4$)

$5^2 = 25$ therefore square root of 25 is 5 ($\sqrt{25} = 5$)

If $y^2 = x$ then square root of x is y ($\sqrt{x} = y$)

- Example 2:**
- $\sqrt{4} = 2$ because $2^2 = 4$
 - $\sqrt{16} = 4$ because $4^2 = 16$
 - $\sqrt{225} = 15$ because $15^2 = 225$ etc.

25 is the square of both 5 and -5.

Therefore, the square root of 25 is 5 or -5.

But in this chapter we are confined to the positive square root which is also called principal square root.

It is written as

$$\therefore \sqrt{25} = 5.$$

Complete the following table.

Square	Square roots
$1^2 = 1$	$\sqrt{1} = 1$
$2^2 = 4$	$\sqrt{4} = 2$
$3^2 = 9$	$\sqrt{9} = 3$
$4^2 = 16$	$\sqrt{16} = 4$
$5^2 = 25$	$\sqrt{25} = \dots\dots$
$6^2 = 36$	$\sqrt{36} = \dots\dots$
$7^2 = \dots\dots$	$\sqrt{\quad} = \dots\dots$
$8^2 = \dots\dots$	$\sqrt{\quad} = \dots\dots$
$9^2 = \dots\dots$	$\sqrt{\quad} = \dots\dots$
$10^2 = \dots\dots$	$\sqrt{\quad} = \dots\dots$

6.5 Finding the Square root through subtraction of successive odd numbers

We know that, every square number can be expressed as a sum of successive odd natural numbers starting from 1.

$$\begin{aligned}\text{Consider, } 1 + 3 &= 4 = 2^2 \\ 1 + 3 + 5 &= 9 = 3^2 \\ 1 + 3 + 5 + 7 &= 16 = 4^2 \\ 1 + 3 + 5 + 7 + 9 &= 25 = 5^2\end{aligned}$$

Finding square root is the reverse order of this pattern.

For example, find $\sqrt{49}$

$$\begin{aligned}\text{Step 1: } 49 - 1 &= 48 && \text{(Subtracting of first odd number)} \\ \text{Step 2: } 48 - 3 &= 45 && \text{(Subtracting of 2}^{\text{nd}} \text{ odd number)} \\ \text{Step 3: } 45 - 5 &= 40 && \text{(Subtracting of 3}^{\text{rd}} \text{ odd number)} \\ \text{Step 4: } 40 - 7 &= 33 \\ \text{Step 5: } 33 - 9 &= 24 \\ \text{Step 6: } 24 - 11 &= 13 \\ \text{Step 7: } 13 - 13 &= 0\end{aligned}$$

Observe we know

$$1 + 3 + 5 + 7 + 9 + 11 + 13 = 7^2 = 49$$

$$49 - [1 + 3 + 5 + 7 + 9 + 11 + 13] = 0$$

Hence 49 is a perfect square.

From 49, we have subtracted seven successive odd numbers starting from 1 and obtained zero (0) at 7th step.

$$\therefore \sqrt{49} = 7$$

Note: If the result of this process is not zero then the given number is not a perfect square.



Do This

1. By subtraction of successive odd numbers find whether the following numbers are perfect squares or not?

(i) 55

(ii) 90

(iii) 121

It is easy to find the square roots of any square numbers by the above subtraction process. But in case of bigger numbers such as 625, 729..... it is time taking process. So, Let us try to find simple ways to obtain the square roots.

There are two methods of finding the square root of the given numbers. They are

- (i) Prime factorization method
- (ii) Division method

6.6 Finding the Square Root Through Prime Factorisation Method

Let us find the square root of 484 by prime factorization method.

Step 1: Resolve the given number 484 into prime factors, we get

$$484 = 2 \times 2 \times 11 \times 11$$

Step 2: Make pairs of equal factors, we get

$$484 = (2 \times 2) \times (11 \times 11)$$

Step 3: Choosing one factor out of every pair

By doing so, we get

$$\sqrt{484} = 2 \times 11 = 22$$

Therefore, the square root of 484 is 22.

Now we will see some more examples

Example 3 : Find the square root of 1296 by Prime Factorization

Solution : Resolving 1296 into Prime factors, we get

$$1296 = (2 \times 2) \times (2 \times 2) \times (3 \times 3) \times (3 \times 3)$$

$$\sqrt{1296} = 2 \times 2 \times 3 \times 3$$

$$\therefore \sqrt{1296} = 36$$

Example 4 : Find the square root of 2025

Solution : Resolving 2025 into Prime factors, we get

$$2025 = (3 \times 3) \times (3 \times 3) \times (5 \times 5)$$

$$\sqrt{2025} = 3 \times 3 \times 5$$

$$\therefore \sqrt{2025} = 45$$

2	484
2	242
11	121
11	11
	1

$$484 = (2 \times 11) \times (2 \times 11) = (2 \times 11)^2$$

$$\sqrt{484} = \sqrt{(2 \times 11)^2}$$

$$= 2 \times 11$$

$$= 22$$

2	1296
2	648
2	324
2	162
3	81
3	27
3	9
3	3
	1

5	2025
5	405
3	81
3	27
3	9
3	3
	1

Example 5: Find the smallest number by which 720 should be multiplied to get a perfect square.

Solution : Resolving 720 into Prime factors, we get

$$720 = (2 \times 2) \times (2 \times 2) \times (3 \times 3) \times 5$$

We see that 2, 2, 3 exist in pairs, while 5 is alone

So, we should multiply the given number by 5 to get a perfect square.

Therefore, the perfect square so obtained is

$$720 \times 5 = 3600$$

2	720
2	360
2	180
2	90
3	45
3	15
5	5
	1

Example 6: Find the smallest number by which 6000 should be divided to get a perfect square and also find the square root of the resulting number.

Solution : Resolving 6000 into Prime factors, we get

$$6000 = \underline{2 \times 2} \times \underline{2 \times 2} \times 3 \times \underline{5 \times 5} \times 5$$

We can see that, 2, 2, and 5 exists in pairs while 3 and 5 do not exists in pairs

So, we must divide the given number by $3 \times 5 = 15$

Therefore perfect square obtained = $6000 \div 15 = 400$

$$400 = 2 \times 2 \times 2 \times 2 \times 5 \times 5$$

The square root of 400 is

$$\begin{aligned} \sqrt{400} &= \sqrt{(2 \times 2) \times (2 \times 2) \times (5 \times 5)} \\ &= 2 \times 2 \times 5 \\ &= 20 \end{aligned}$$

2	6000
2	3000
2	1500
2	750
3	375
5	125
5	25
5	5
	1
2	400
2	200
2	100
2	50
5	25
5	5
	1



Exercise - 6.2

1. Find the square root of the following numbers by Prime factorization method.

- (i) 441 (ii) 784 (iii) 4096 (iv) 7056

2. Find the smallest number by which 3645 must be multiplied to get a perfect square.
3. Find the smallest number by which 2400 is to be multiplied to get a perfect square and also find the square root of the resulting number.
4. Find the smallest number by which 7776 is to be divided to get a perfect square.
5. 1521 trees are planted in a garden in such a way that there are as many trees in each row as there are rows in the garden. Find the number of rows and number of trees in each row.
6. A school collected ₹ 2601 as fees from its students. If fee paid by each student and number students in the school were equal, how many students were there in the school?
7. The product of two numbers is 1296. If one number is 16 times the other, find the two numbers?
8. 7921 soldiers sat in an auditorium in such a way that there are as many soldiers in a row as there are rows in the auditorium. How many rows are there in the auditorium?
9. The area of a square field is 5184 m^2 . Find the area of a rectangular field, whose perimeter is equal to the perimeter of the square field and whose length is twice of its breadth.

6.7 Finding square root by division method

We have already discussed the method of finding square root by prime factorisation method. For large numbers, it becomes lengthy and difficult. So, to overcome this problem we use division method.

Let us find the square root of 784 by division method.

$\overline{784}$	Step 1 : Pair the digits of the given number, starting from units place to the left. Place a bar on each pair.
------------------	--

$\begin{array}{r} 2 \\ \overline{784} \end{array}$	Step 2 : Find the largest number whose square is less than or equal to the first pair or single digit from left (i.e. 2). Take this number as the divisor and the quotient.
--	---

$\begin{array}{r} 2 \\ \overline{784} \\ 4 \\ \hline 3 \end{array}$	Step 3 : Subtract the product of the divisor and quotient ($2 \times 2 = 4$) from first pair or single digit (i.e. $7 - 4 = 3$)
---	--

$\begin{array}{r} 2 \\ \overline{784} \\ -4 \\ \hline 384 \end{array}$	Step 4 : Bring down the second pair (i.e. 84) to the right of the Remainder (i.e. 3). This becomes the new dividend (i.e. 384).
--	---

$\begin{array}{r} 2 \\ \overline{784} \\ -4 \\ \hline 4 \square \end{array}$	Step 5 : From the next possible divisor double the quotient (i.e. $2 \times 2 = 4$) and write a box on its right.
--	--

$$\begin{array}{r|l}
 2 & \overline{784} & 28 \\
 & -4 & \\
 \hline
 4\boxed{8} & 384 & \\
 & 384 & \\
 \hline
 & 0 &
 \end{array}$$

Step 6: Guess the largest possible digit to fill the box in such a way that the product of the new divisor and this digit is equal to or less than the new dividend (i.e. $48 \times 8 = 384$).

$$\begin{array}{r|l}
 2 & \overline{784} & 28 \\
 & -4 & \\
 \hline
 48 & 384 & \\
 & -384 & \\
 \hline
 & 0 &
 \end{array}$$

Step 7: By subtracting, we get the remainder zero. The final quotient 28, is the square root of 784
 $\therefore \sqrt{784} = 28$

Think, Discuss and Write

Observe the following divisions, give reasons why 8 in the divisor 48 is considered in the above example?

$$\begin{array}{r}
 4 \overline{) 384} \quad (9) \\
 \underline{36} \\
 24 \\
 \underline{81} \\
 81 = 9^2
 \end{array}$$

$$\begin{array}{r}
 4 \overline{) 384} \quad (8) \\
 \underline{32} \\
 64 \\
 \underline{64} \\
 64 = 8^2
 \end{array}$$

$$\begin{array}{r}
 4 \overline{) 384} \quad (7) \\
 \underline{28} \\
 104 \\
 \underline{49} \\
 49 = 7^2
 \end{array}$$

Now, we will see some more examples.

Example 7: Find the square root of 1296

Solution: Step 1

Step 2

$$\begin{array}{r|l}
 3 & \overline{1296} & 3 \\
 & 9 &
 \end{array}$$

Step 3

$$\begin{array}{r|l}
 3 & \overline{1296} & 3 \\
 & -9 &
 \end{array}$$

Step 4

$$\begin{array}{r|l}
 3 & \overline{1296} & 3 \\
 & -9 & \\
 \hline
 6 & 396 &
 \end{array}$$

Step 5

$$\begin{array}{r|l}
 3 & \overline{1296} & 36 \\
 & -9 & \\
 \hline
 66 & 396 & \\
 & -396 & \\
 \hline
 & 0 &
 \end{array}$$

Observe
$ \begin{array}{r} 6 \overline{) 396} \quad (6) \\ \underline{36} \\ 36 \\ \underline{36} \\ 0 \\ 36 = 6^2 \end{array} $

$\therefore \sqrt{1296} = 36$

Example 8: Find the square root of 8281

Solution:

$$\begin{array}{r|l} 9 & \overline{82\ 81} & 91 \\ & -81 & \\ \hline 181 & 181 & \\ & -181 & \\ \hline & 0 & \end{array}$$

Therefore $\sqrt{8281} = 91$

Observe	
18	181
	18
	1
	1 = 1 ²
	0

Example 9: Find the greatest four digit number which is a perfect square

Solution: Greatest four digit number is 9999

We find square root of 9999 by division method.

The remainder 198 shows that it is less than 9999 by 198

This means if we subtract 198 from 9999, we get a perfect square.

$$\therefore 9999 - 198 = 9801$$

\therefore 9801 is the required perfect square.

$$\begin{array}{r|l} 9 & \overline{99\ 99} & 99 \\ & -81 & \\ \hline 189 & 18\ 99 & \\ & -17\ 01 & \\ \hline & 1\ 98 & \end{array}$$

Example 10: Find the least number which must be subtracted from 4215 to make it a perfect square?

Solution: We find by division method that

The remainder is 119

This means, if we subtract 119 from 4215. We get a perfect square.

Hence, the required least number is 119.

$$\begin{array}{r|l} 6 & \overline{42\ 15} & 64 \\ & -36 & \\ \hline 124 & 6\ 15 & \\ & -4\ 96 & \\ \hline & 1\ 19 & \end{array}$$

6.8 Square root of decimal numbers using division method

Let us begin with the example $\sqrt{17.64}$.

Step 1: Place the bars on the integral part of the number i.e. 17 in the usual manner. Place the bars on every pair of decimal part from left to right

$$\overline{17.64}$$

Step 2: Find the largest number (i.e. 4) whose square is less than or equal to the first pair of integral part (i.e. 17).

Take this number 4 as a divisor and the first pair 17 as the dividend. Get the remainder as 1 (By doing division).

$$\begin{array}{r|l} 4 & \overline{17.64} & 4 \\ & -16 & \\ \hline & 1 & \end{array}$$

Step 3: Write the next pair (i.e. 64) to the right of the remainder to get 164, which becomes the new dividend.

$$\begin{array}{r|l} 4 & \overline{17.64} & 4 \\ & -16 & \\ \hline & 1.64 & \end{array}$$

Step 4: Double the quotient ($2 \times 4 = 8$) and write it as 8 in the box on its right. Since 64 is the decimal part so, put a decimal point in the quotient (i.e. 4)

$$\begin{array}{r|l|l} 4 & \overline{17.64} & 4 \\ & -16 & \\ \hline 8\Box & -164 & \end{array}$$

Step 5: Guess the digit to fill the box in such a way that the product of the new divisor and the digit is equal to or less than the new dividend 164. In this case the digit is 2. Divide and get the remainder.

$$\begin{array}{r|l|l} 4 & \overline{17.64} & 4.2 \\ & -16 & \\ \hline 8\boxed{2} & -164 & \\ & -164 & \\ \hline & 0 & \end{array}$$

Step 6: Since the remainder is zero and no pairs left.

$$\sqrt{17.64} = 4.2$$

Now, let us see some more examples.

Example 11: Find the square root of 42.25 using division method.

Solution:

$$\begin{array}{l} \text{Step 1 :} \\ \begin{array}{r|l|l} & \overline{42.25} & \\ 6 & \overline{42.25} & 6 \\ & -36 & \\ \hline & 6 & \end{array} \\ \text{Step 2 :} \\ \begin{array}{r|l|l} & \overline{42.25} & 6.5 \\ 6 & \overline{42.25} & 6.5 \\ & -36 & \\ \hline 125 & 625 & \\ & -625 & \\ \hline & 0 & \end{array} \end{array}$$

$$\therefore \sqrt{42.25} = 6.5$$

Example 12: Find $\sqrt{96.04}$.

Solution:

$$\begin{array}{r|l|l} 9 & \overline{96.04} & 9.8 \\ 9 & -81 & \\ \hline 188 & 1504 & \\ & -1504 & \\ \hline & 0 & \end{array}$$

$$\text{Therefore } \sqrt{96.04} = 9.8$$

6.9 Estimating square roots of non perfect square numbers

So far we have learnt the method for finding the square roots of perfect squares. If the numbers are not perfect squares, then we will not be able to find the exact square roots. In all such cases we atleast need to estimate the square root.

Let us estimate the value of $\sqrt{300}$ to the nearest whole number.

300 lies between two perfect square numbers 100 and 400

$$\therefore 100 < 300 < 400$$

$$10^2 < 300 < 20^2$$

$$\text{i.e. } 10 < \sqrt{300} < 20$$

But still we are not very close to the square number. we know that $17^2 = 289$, $18^2 = 324$

Therefore $289 < 300 < 324$

$$17 < \sqrt{300} < 18$$

As 289 is more closer to 300 than 324.

The approximate value of $\sqrt{300}$ is 17.



Exercise - 6.3

- Find the square root of the following numbers by division method.
(i) 1089 (ii) 2304 (iii) 7744 (iv) 6084 (v) 9025
- Find the square root of the following decimal numbers.
(i) 2.56 (ii) 18.49 (iii) 68.89 (iv) 84.64
- Find the least number that is to be subtracted from 4000 to make it perfect square
- Find the length of the side of a square whose area is 4489 sq.cm.
- A gardener wishes to plant 8289 plants in the form of a square and found that there were 8 plants left. How many plants were planted in each row?
- Find the least perfect square with four digits.
- Find the least number which must be added to 6412 to make it a perfect square?
- Estimate the value of the following numbers to the nearest whole number
(i) $\sqrt{97}$ (ii) $\sqrt{250}$ (iii) $\sqrt{780}$

Cubes and Cube Roots

6.10 Cubic Numbers

We know that a cube is a solid figure with six identical squares as its faces.



Now let us make cubic shapes using these unit cubes

S.No.	Figure	Length of the side	No. of unit cubes used
1		1	1
2		2	8
3		3	27

Can you make next cube?

Guess how many unit cubes are required to make a cube whose side is 5 units?

So, we require 1, 8, 27, 64 unit cubes to make cubic shapes.

These numbers 1, 8, 27, 64 are called cubic numbers or perfect cubes.

As $1 = 1 \times 1 \times 1 = 1^3$
 $8 = 2 \times 2 \times 2 = 2^3$
 $27 = 3 \times 3 \times 3 = 3^3$
 $64 = \dots \times \dots \times \dots =$

So, a cube number is obtained when a number is multiplied by itself for three times.

That is, cube of a number 'x' is $x \times x \times x = x^3$

Is 49 a cube number ?

No, as $49 = 7 \times 7$ and there is no natural number which when multiplied by itself three times gives 49. We can also see that $3 \times 3 \times 3 = 27$ and $4 \times 4 \times 4 = 64$. This shows that 49 is not a perfect cube.



Try These

1. Is 81 a perfect cube?
2. Is 125 a perfect cube?

Observe and complete the following table.

Number	Cube
1	$1^3 = 1 \times 1 \times 1 = 1$
2	$2^3 = 2 \times 2 \times 2 = 8$
3	$3^3 = 3 \times 3 \times 3 = 27$
4	$4^3 = 4 \times 4 \times 4 = 64$
5	$5^3 = 5 \times 5 \times 5 = 125$
6	$6^3 = 6 \times 6 \times 6 = \dots\dots\dots$
7	$7^3 = \dots\dots\dots = \dots\dots\dots$
8	$8^3 = \dots\dots\dots = \dots\dots\dots$
9	$9^3 = \dots\dots\dots = \dots\dots\dots$
10	$10^3 = \dots\dots\dots = \dots\dots\dots$



Think, Discuss and Write

- (i) How many perfect cube numbers are present between 1 and 100, 1 and 500, 1 and 1000?
- (ii) How many perfect cubes are there between 500 and 1000 ?

Following are the cubes of numbers from 11 to 20

Number	Cube
11	1331
12	1728
13	2197
14	2744
15	3375
16	4096
17	4913
18	5832
19	6859
20	8000

Do you find anything interesting in the sum of the digits in the cubes of 17 and 18 ?

From the table, we can see that cube of an even number is always an even number. Do you think the same is true for odd numbers also?

We can also observe that, if a number has 1 in the units place, then its cube ends with 1.

Similarly, what can you say about the units digit of the cube of a number having 0, 4, 5, 6 or 9 as the units digit?



Try These

1. Find the digit in units place of each of the following numbers.

- (i) 75^3 (ii) 123^3 (iii) 157^3 (iv) 198^3 (v) 206^3

6.11 Some interesting patterns

1. Adding consecutive odd numbers

Observe the following patterns.

$$1 = 1 = 1^3$$

$$3 + 5 = 8 = 2^3$$

$$7 + 9 + 11 = 27 = 3^3$$

$$13 + 15 + 17 + 19 = \dots = \dots$$

Can you guess how many next consecutive odd numbers will be needed to obtain the sum as 5^3 ?

2. Consider the following pattern

$$\begin{aligned}2^3 - 1^3 &= 1 + 2 \times 1 \times 3 = 7 \\3^3 - 2^3 &= 1 + 3 \times 2 \times 3 = 19 \\4^3 - 3^3 &= 1 + 4 \times 3 \times 3 = 37 \\5^3 - 4^3 &= \dots\dots\dots = \dots\dots\dots\end{aligned}$$

Using the above pattern find the values of the following

(i) $10^3 - 9^3$ (ii) $15^3 - 14^3$ (iii) $26^3 - 25^3$

3. Observe the following pattern and complete it

$$\begin{aligned}1^3 &= 1^2 \\1^3 + 2^3 &= (1 + 2)^2 = (3)^2 \\1^3 + 2^3 + 3^3 &= (1 + 2 + 3)^2 = ()^2 \\1^3 + 2^3 + 3^3 + 4^3 &= (\text{---})^2 \\ \dots\dots\dots &= (1 + 2 + 3 + \dots + 10)^2\end{aligned}$$

Hence we can generalize that the sum of the cubes of first 'n' natural numbers is equal to the square of their sum.

i.e. $1^3 + 2^3 + 3^3 + \dots\dots\dots + n^3 = (1 + 2 + 3 + \dots + n)^2$.

6.12 Cubes and their Prime Factors

Consider the numbers 64 and 216

Resolving 64 and 216 into prime factors

$$\begin{aligned}64 &= \underline{2 \times 2 \times 2} \times \underline{2 \times 2 \times 2} \\216 &= \underline{2 \times 2 \times 2} \times \underline{3 \times 3 \times 3}\end{aligned}$$

In both these cases each factor appears three times. That is the prime factors can be grouped in triples.

Thus, if a number can be expressed as a product of three equal factors then it is said to be a perfect cube or cubic number.

Is 540 a perfect cube?

Resolving 540 into prime factors, we get

$$540 = 2 \times 2 \times 3 \times 3 \times 3 \times 5$$

Here, 2 and 5 do not appear in groups of three. Hence 540 is not a perfect cube.

2	540
2	270
3	135
3	45
3	15
5	5
	1



Do These

1. Which of the following are perfect cubes?

- (i) 243 (ii) 400 (iii) 500 (iv) 512 (v) 729

Example 13: What is a smallest number by which 2560 is to be multiplied so that the product is a perfect cube?

Solution : Resolving 2560 into prime factors, we get

$$2560 = \underline{2 \times 2 \times 2} \times \underline{2 \times 2 \times 2} \times \underline{2 \times 2 \times 2} \times 5$$

The Prime factor 5 does not appear in a group of three.

So, 2560 is not a perfect cube.

Hence, the smallest number by which it is to be multiplied to make it a perfect cube is $5 \times 5 = 25$

2	2560
2	1280
2	640
2	320
2	160
2	80
2	40
2	20
2	10
	5

Example 14: What is the smallest number by which 1600 is to be divided. so that the quotient is a perfect cube?

Solution : Resolving 1600 into prime factors, we get

$$1600 = \underline{2 \times 2 \times 2} \times \underline{2 \times 2 \times 2} \times 5 \times 5$$

The prime factor 5 does not appear in a group of three factors. So, 1600 is not a perfect cube.

Hence, the smallest number which is to be divided to make it a perfect cube is $5 \times 5 = 25$

2	1600
2	800
2	400
2	200
2	100
2	50
5	25
	5



Exercise - 6.4

- Find the cube of the following numbers
(i) 8 (ii) 16 (iii) 21 (iv) 30
- Test whether the given numbers are perfect cubes or not.
(i) 243 (ii) 516 (iii) 729 (iv) 8000 (v) 2700
- Find the smallest number by which 8788 must be multiplied to obtain a perfect cube?
- What smallest number should 7803 be multiplied with so that the product becomes a perfect cube?
- Find the smallest number by which 8640 must be divided so that the quotient is a perfect cube?
- Ravi made a cuboid of plasticine of dimensions 12cm, 8cm and 3cm. How many minimum number of such cuboids will be needed to form a cube?
- Find the smallest prime number dividing the sum $3^{11} + 5^{13}$.

6.13 Cube roots

We know that, we require 8 unit cubes to form a cube of side 2 units ($2^3 = 8$)

Similarly, we need 27 unit cubes to form a cube of side 3 units ($3^3 = 27$)

Suppose, a cube is formed with 64 unit cubes. Then what could be the side of the cube?

Let us assume, the length of the side to be 'x'

$$\therefore 64 = x^3$$

To find the side of a cube, it is necessary to find a number whose cube is 64. Therefore, finding the number whose cube is known is called finding the cube root.

It is the inverse operation of cubing.

As, $4^3 = 64$ then 4 is called cube root of 64. We write $\sqrt[3]{64} = 4$. The symbol $\sqrt[3]{\quad}$ denotes cube root.

Hence, a number 'x' is the cube root of another number y, if $y = x^3$ then $x = \sqrt[3]{y}$.

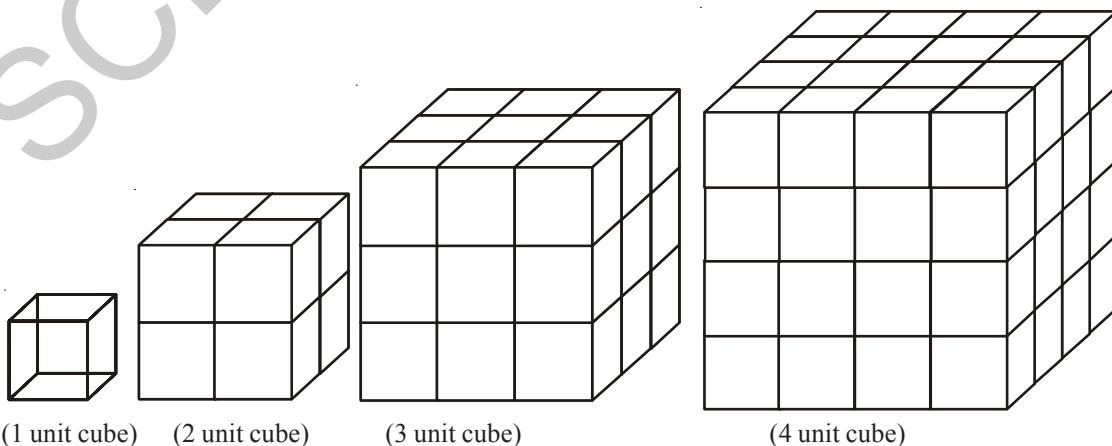

Complete the following table.

Cubes	Cube roots
$1^3 = 1$	$\sqrt[3]{1} = 1$
$2^3 = 8$	$\sqrt[3]{8} = 2$
$3^3 = 27$	$\sqrt[3]{27} = 3$
$4^3 = 64$	$\sqrt[3]{64} = 4$
$5^3 = 125$	$\sqrt[3]{125} = 5$
$6^3 = \dots\dots$	$\sqrt[3]{} = 6$
$7^3 = \dots\dots$	$\sqrt[3]{} = 7$
$8^3 = \dots\dots$	$\sqrt[3]{} = 8$
$\dots\dots = \dots\dots$	$\dots\dots = \dots\dots$
$\dots\dots = \dots\dots$	$\dots\dots = \dots\dots$

6.14 Finding cube root through Prime Factorization method

Let us find the cube root of 1728 by prime factorization method.

Step 1 : Resolve the given number 1728 into prime factors.

$$1728 = 2 \times 2 \times 2 \times 2 \times 2 \times 2 \times 3 \times 3 \times 3$$

Step 2 : Make groups of three equal factors:

$$1728 = (2 \times 2 \times 2) \times (2 \times 2 \times 2) \times (3 \times 3 \times 3)$$

Step 3: Choose one factor from each group and multiply by doing so, we get

$$\sqrt[3]{1728} = 2 \times 2 \times 3 = 12$$

Let us see some more examples

Example 15: Find the cube root of 4096 ?

Solution : Resolving 4096 into Prime Factors, we get

$$4096 = (2 \times 2 \times 2) \times (2 \times 2 \times 2) \times (2 \times 2 \times 2) \times (2 \times 2 \times 2)$$

$$\sqrt[3]{4096} = 2 \times 2 \times 2 \times 2 = 16$$

$$\therefore \sqrt[3]{4096} = 16$$

2	1728
2	864
2	432
2	216
2	108
2	54
3	27
3	9
	3
2	4096
2	2048
2	1024
2	512
2	256
2	128
2	64
2	32
2	16
2	8
2	4
	2

6.15 Estimating the cube root of a number

If we know, the given number is a cube number then to find its cube root the following method can be used.

Let us find the cube root of 9261 through estimation.

Step 1: Start making groups of three digits starting from the unit place.

i.e. 9 261
 second first
 group group

Step 2: First group i.e. 261 will give us the units digit of the cube root. As 261 ends with 1, its cube root also ends with 1. So, the units place of the cube root will be 1.

Step 3: Now, take second group i.e. 9.

We know that $2^3 < 9 < 3^3$. As the smallest number is 2, it becomes the tens place of the required cube root

$$\therefore \sqrt[3]{9261} = 21$$



Exercise - 6.5

- Find the cube root of the following numbers by prime factorization method.
 - 343
 - 729
 - 1331
 - 2744
- Find the cube root of the following numbers through estimation?
 - 512
 - 2197
 - 3375
 - 5832
- State true or false?
 - Cube of an even number is an odd number
 - A perfect cube may end with two zeros
 - If a number ends with 5, then its cube ends with 5
 - Cube of a number ending with zero has three zeros at its right
 - The cube of a single digit number is a single digit number.
 - There is no perfect cube which ends with 8
 - The cube of a two digit number may be a three digit number.
- Find the two digit number which is a square number and also a cubic number.



What we have discussed



- Estimating number of digits in square of a number.
- Square numbers written in different patterns.
- a, b, c are positive integers and if $a^2 + b^2 = c^2$ then (a, b, c) are said to be Pythagorean triplets.
- Finding the square roots by prime factorisation and division method.
- Square root is the inverse operation of squaring.
- Estimating square roots of non perfect square numbers.
- If a number is multiplied three times by itself is called cube number.
- Finding cube root by prime factorisation method.
- Estimating cube roots of a number.
- The square of integer is an integer and a square number, where as square of rational number is a perfect square, not a square number.

Eternal triangle

The formulau that give sides of a right - angled triangle have been known since the time of Diophantus and the early Greeks. They are

one side $X = m^2 - n^2$

second side $Y = 2mn$

Hypotenuse $Z = m^2 + n^2$

The numbers m & n are integers which may be arbitrarily selected.

Example

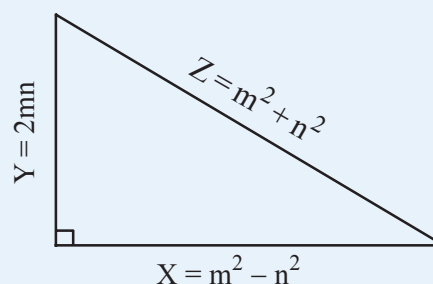

m	n	$X = m^2 - n^2$	$Y = 2mn$	$Z = m^2 + n^2$
2	1	3	4	5
3	2	5	12	13
5	2	21	20	29
4	3	7	24	25
4	1	15	8	17



7.0 Introduction

Jagadeesh watching T.V. A visual appeared on the T.V. screen showing the details of medals won by different countries in Olympics 2012.

Olympics 2012 - Medals Tally

Rank	Country	Gold	Silver	Bronze	Total
1	United States of America	46	29	29	104
2	China	38	27	23	88
3	Britain	29	17	19	65
4	Russia	24	26	32	82
5	Korea	13	8	7	28



The above table provides data about the top five countries that got the highest number of medals in the olympics 2012 as well as the number of medals they won.

Information, available in the numerical form or verbal form or graphical form that helps in taking decisions or drawing conclusions is called **Data**.

- Which country has got the highest number of medals ?
- Which country has got the highest number of bronze medals ?
- Write three more questions based on data provided in the table .



Try This

Give any three examples of data which are in situations or in numbers.

7.1 Basic measures of central tendency

Usually we collect data and draw certain conclusions based on the nature of data. Understanding its nature, we do certain computations like mean, median and mode which are referred as measures of central tendency. Let us recall.

7.1.1 Arithmetic Mean

It is the most commonly used measure of central tendency. For a set of numbers, the mean is simply the average, i.e., sum of all observations divided by the number of observations.

Arithmetic mean of $x_1, x_2, x_3, x_4, \dots, x_n$ is

$$\text{Arithmetic mean} = \frac{x_1 + x_2 + x_3 + \dots + x_n}{N}$$

$$\bar{x} = \frac{\sum x_i}{N} \quad (\text{short representation})$$

$\sum x_i$ represents the sum of all x_i where i takes the values from 1 to n . And N is the total number of observations.

Example 1: Ashok got the following marks in different subjects in a unit test. 20, 11, 21, 25, 23 and 14. What is arithmetic mean of his marks?

Solution: Observations = 20, 11, 21, 25, 23 and 14

$$\begin{aligned} \text{Arithmetic mean } \bar{x} &= \frac{\sum x_i}{N} \\ &= \frac{20 + 11 + 21 + 25 + 23 + 14}{6} = \frac{114}{6} \\ \bar{x} &= 19 \end{aligned}$$

Example 2: Arithmetic mean of 7 observations was found to be 32. If one more observation 48 was to be added to the data what would be the new mean of the data?

Solution:

$$\begin{aligned} \text{Mean of 7 observations } \bar{x} &= 32 \\ \text{Sum of 7 observations is } \sum x_i &= 32 \times 7 = 224 \\ \text{Added observation} &= 48 \\ \text{Sum of 8 observations } \sum x_i &= 224 + 48 = 272 \\ \therefore \text{Mean of 8 observations } \bar{x} &= \frac{\sum x_i}{N} = \frac{272}{8} = 34 \end{aligned}$$

Example 3: Mean age of 25 members of a club was 38 years. If 5 members with mean age of 42 years have left the club, what is the present mean age of the club members?

Solution: Mean age of 25 members of the club = 38 years

$$\begin{aligned}
\text{Total age of 25 members} &= 38 \times 25 = 950 \text{ years} \\
\text{Mean age of 5 members} &= 42 \text{ years} \\
\text{Total age of 5 members} &= 42 \times 5 = 210 \text{ years} \\
\text{Total age of remaining 20 members} &= 950 - 210 = 740 \text{ years} \\
\therefore \text{ Present mean age of club members } \bar{x} &= \frac{\sum x_i}{N} = \frac{740}{20} = 37 \text{ years}
\end{aligned}$$

Example 4: Arithmetic mean of 9 observations was calculated as 45. In doing so an observation was wrongly taken as 42 for 24. What would be the correct mean?

Solution:

$$\begin{aligned}
\text{Mean of 9 observations} &= 45 \\
\text{Sum of 9 observations} &= 45 \times 9 = 405 \\
\text{When computing mean 42 was taken instead of 24} & \\
\therefore \text{ Correct sum of 9 observations} &= 405 - 42 + 24 = 387 \\
\text{Actual mean of 9 observations} &= \frac{\sum x_i}{N} = \frac{387}{9} = 43
\end{aligned}$$

We observe,

- From the above examples we can see that Arithmetic Mean is a representative value of the entire data.
- Arithmetic mean depends on both number of observations and value of each observation in a data.
- It is unique value of the data.
- When all the observations of the data are increased or decreased by a certain number, the mean also increases or decreases by the same number.
- When all the observations of the data are multiplied or divided by a certain number, the mean also multiplied or divided by the same number.

7.1.2 Arithmetic Mean by Deviation Method

There are five observations in a data, 7, 10, 15, 21, 27. When the teacher asked to estimate the Arithmetic Mean of the data without actual calculation, some students are estimated as follows:

Kamal estimated that it lies exactly between minimum and maximum values, i.e. 17,
 Neelima estimated that it is the middle value of the ordered (ascending or descending) data; 15,
 Lekhya added all the observations and divided by their number, i.e. 16.

We call each of these estimations as 'estimated mean' or 'assumed mean' is represented with 'A'.
 Let us verify which of the estimations coincides with the actual mean of the above three students.

Case 1: Consider Kamal's estimated arithmetic mean $A = 17$

$$\text{Their actual arithmetic mean is } \bar{x} = \frac{\sum x_i}{N} = \frac{7+10+15+21+27}{5} = \frac{80}{5} = 16$$

If each observation is written in terms of deviation from assumed mean A , we have

Score	A	in Terms of Deviations
7	17	$7 = 17 - 10$
10	17	$10 = 17 - 7$
15	17	$15 = 17 - 2$
21	17	$21 = 17 + 4$
27	17	$27 = 17 + 10$

$$\bar{x} = \frac{(17-10)+(17-7)+(17-2)+(17+4)+(17+10)}{5}$$

$$= \frac{5 \times 17}{5} + \frac{-10-7-2+4+10}{5}$$

$$= 17 + \frac{-5}{5} = 17 - 1 = 16$$

\therefore Arithmetic mean = Estimated mean + Average of deviations

Case 2: Consider Neelima's estimated arithmetic mean $A = 15$

$$\text{Their arithmetic mean is } \bar{x} = \frac{\sum x_i}{N} = \frac{7+10+15+21+27}{5}$$

$$\Rightarrow \bar{x} \text{ in terms of deviations} = \frac{(15-8)+(15-5)+(15-0)+(15+6)+(15+12)}{5}$$

$$= \frac{(5 \times 15)}{5} + \frac{(-8-5-0+6+12)}{5}$$

$$= 15 + \frac{5}{5} = 15 + 1 = 16$$

Case 3: Consider Lekhya's estimated arithmetic mean $A = 16$

$$\text{Their arithmetic mean is } \bar{x} = \frac{\sum x_i}{N} = \frac{7+10+15+21+27}{5}$$

$$\Rightarrow \bar{x} \text{ in terms of deviations} = \frac{(16-9)+(16-6)+(16-1)+(16+5)+(16+11)}{5}$$

$$= \frac{(5 \times 16)}{5} + \frac{(-9-6-1+5+11)}{5}$$

$$= 16 + \frac{0}{5} = 16$$



Try These

Prepare a table of estimated mean, deviations of the above cases. Observe the average of deviations with the difference of estimated mean and actual mean. What do you infer?

[**Hint:** Compare with average deviations]

It is clear that the estimated mean becomes the actual arithmetic mean if the sum (or average) of deviations of all observations from the estimated mean is 'zero'.

We may use this verification process as a mean to find the Arithmetic Mean of the data.

From the above cases, it is evident that the arithmetic mean may be found through the estimated mean and deviation of all observations from it.

Arithmetic mean = Estimated mean + Average of deviation

$$= \text{Estimated mean} + \frac{\text{Sum of deviations}}{\text{Number of observations}}$$

$$\bar{x} = A + \frac{\sum(x_i - A)}{N}$$

The difference between any score of data and assumed mean is called deviations.

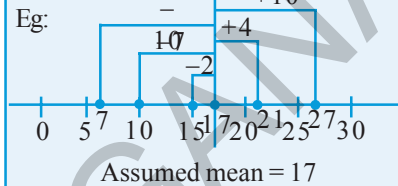

Example 5: Find the arithmetic mean of 10 observations 14, 36, 25, 28, 35, 32, 56, 42, 50, 62 by assuming mean as 40. Also find mean by regular formula. Do you find any difference.

Solution: Observations of the data = 14, 25, 28, 32, 35, 36, 42, 50, 56, 62

Let the assumed mean $A = 40$

$$\therefore \text{Arithmetic mean} = A + \frac{\sum(x_i - A)}{N}$$

$$\bar{x} = 40 + \frac{(14 - 40) + (25 - 40) + (28 - 40) + (32 - 40) + (35 - 40) + (36 - 40) + (42 - 40) + (50 - 40) + (56 - 40) + (62 - 40)}{10}$$

$$= 40 + \frac{(-26) + (-15) + (-12) + (-8) + (-5) + (-4) + (2) + (10) + (16) + (22)}{10}$$

$$= 40 + \frac{(-70 + 50)}{10}$$

$$= 40 - \frac{20}{10}$$

$$= 40 - 2 = 38$$

By usual formula $\bar{x} = \frac{\sum x_i}{N} = \frac{14 + 25 + 28 + 32 + 35 + 36 + 42 + 50 + 56 + 62}{10}$

$$= \frac{380}{10} = 38$$

In both the methods we got the same mean.

This way of computing arithmetic mean by deviation method is conveniently used for data with large numbers and decimal numbers.

Consider the following example.

Example 6: Market value (in rupees) of a share through a week is changing as 3672, 3657, 3673, 3665, 3668. Find the arithmetic mean of the market value of the share.

Solution: Observations of the data = 3657, 3665, 3668, 3672, 3673

Estimated mean = 3668

$$\begin{aligned}\text{Arithmetic mean } \bar{x} &= A + \frac{\sum(x_i - A)}{N} \\ &= 3668 + \frac{[(3657 - 3668) + (3665 - 3668) + (3668 - 3668) + (3672 - 3668) + (3673 - 3668)]}{5} \\ &= 3668 + \frac{(-11 - 3 - 0 + 4 + 5)}{5} = 3668 + \frac{(-5)}{5} = 3668 - 1 = ₹ 3667.\end{aligned}$$



Try These

1. Estimate the arithmetic mean of the following data
 - (i) 17, 25, 28, 35, 40
 - (ii) 5, 6, 7, 8, 8, 10, 10, 10, 12, 12, 13, 19, 19, 19, 20

Verify your answers by actual calculations.



Project work

1. Collect marks of 10 of your classmates in different subjects in the recent examinations. Estimate the arithmetic mean of marks in each subject and verify them by actual calculations. How many of your estimations represent exact mean?
2. Measure the heights of students of your class and estimate the mean height. Verify their mean from records of your physical education teacher. Do you notice any difference?

7.1.3 Median

Median is another frequently used measure of central tendency. The median is simply the middle term of the distribution when it is arranged in either ascending or descending order, i.e. there are as many observations above it as below it.

If n number of observations in the data arranged in ascending or descending order

When n is odd, $\left(\frac{n+1}{2}\right)^{\text{th}}$ observation is the median.

When n is even, arithmetic mean of two middle observations $\left(\frac{n}{2}\right)^{\text{th}}$ and $\left(\frac{n}{2}+1\right)^{\text{th}}$ is the median of the data.

Example 7: Find the median of 9 observations 14, 36, 25, 28, 35, 32, 56, 42, 50.

Solution: Ascending order of the data = 14, 25, 28, 32, 35, 36, 42, 50, 56

No of observations $n = 9$ (odd number)

$$\begin{aligned}\text{Median of the data} &= \left(\frac{n+1}{2}\right)^{\text{th}} \text{ observation} \\ &= 5^{\text{th}} \text{ observation} = 35\end{aligned}$$

$$\therefore \text{Median} = 35$$

Example 8: If another observation 61 is also included to the above data what would be the median?

Solution: Ascending order of the data = 14, 25, 28, 32, 35, 36, 42, 50, 56, 61

No of observations $n = 10$ (even number)

Then there would be two numbers at the middle of the data.

$$\begin{aligned}\text{Median of the data} &= \text{arithmetic mean of } \left(\frac{n}{2}\right)^{\text{th}} \text{ and } \left(\frac{n}{2}+1\right)^{\text{th}} \text{ observations} \\ &= \text{arithmetic mean of } 5^{\text{th}} \text{ and } 6^{\text{th}} \text{ observations} \\ &= \frac{35+36}{2} = 35.5\end{aligned}$$



Do This

Here are the heights of some of Indian cricketers. Find the median height of the team.

S.No.	Players Name	Heights
1.	VVS Laxman	5'11"
2.	Parthiv Patel	5'3"
3.	Harbhajan Singh	6'0"
4.	Sachin Tendulkar	5'5"
5.	Gautam Gambhir	5'7"
6.	Yuvraj Singh	6'1"
7.	Robin Uthappa	5'9"
8.	Virender Sehwag	5'8"
9.	Zaheer Khan	6'0"
10.	MS Dhoni	5'11"

5' 10" means 5 feet 10 inches

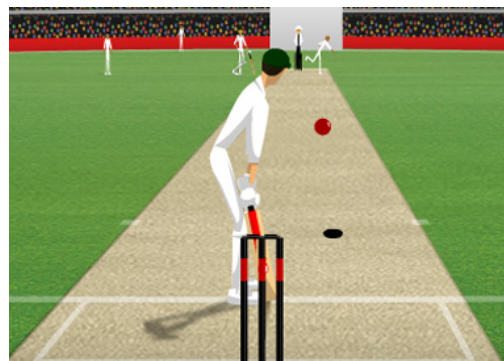

Note:

- Mode is the most frequent observation of the given data.
- It depends neither on number of observations nor values of all observations.
- It is used to analyse both numerical and verbal data.
- There may be 2 or 3 or many modes for the same data.



Exercise - 7.1

1. Find the arithmetic mean of the sales per day in a fair price shop in a week.
₹10000, ₹.10250, ₹.10790, ₹.9865, ₹.15350, ₹.10110
2. Find the mean of the data; 10.25, 9, 4.75, 8, 2.65, 12, 2.35
3. Mean of eight observations is 25. If one observation 11 is excluded, find the mean of the remaining.
4. Arithmetic mean of nine observations is calculated as 38. But in doing so, mistakenly the observation 27 is taken instead of 72. Find the actual mean of the data.
5. Five years ago mean age of a family was 25 years. What is the present mean age of the family?
6. Two years ago the mean age of 40 people was 11 years. Now a person left the group and the mean age has changed to 12 years. Find the age of the person who left the group.
7. Find the sum of deviations of all observations of the data 5, 8, 10, 15, 22 from their mean.
8. If sum of the 20 deviations from the mean is 100, then find the mean deviation.
9. Marks of 12 students in a unit test are given as 4, 21, 13, 17, 5, 9, 10, 20, 19, 12, 20, 14. Assume a mean and calculate the arithmetic mean of the data. Assume another number as mean and calculate the arithmetic mean again. Do you get the same result? Comment.
10. Arithmetic mean of marks (out of 25) scored by 10 students was 15. One of the student, named Karishma enquired the other 9 students and find the deviations from her marks are noted as $-8, -6, -3, -1, 0, 2, 3, 4, 6$. Find Karishma's marks.
11. The sum of deviations of ' n ' observations from 25 is 25 and sum of deviations of the same ' n ' observations from 35 is -25 . Find the mean of the observations.
12. Find the median of the data; 3.3, 3.5, 3.1, 3.7, 3.2, 3.8
13. The median of the following observations, arranged in ascending order is 15.
10, 12, 14, $x - 3$, x , $x + 2$, 25. Then find x .
14. Find the mode of 10, 12, 11, 10, 15, 20, 19, 21, 11, 9, 10.

15. Mode of certain scores is x . If each score is decreased by 3, then find the mode of the new series.
16. Find the mode of all digits used in writing the natural numbers from 1 to 100.
17. Observations of a raw data are 5, 28, 15, 10, 15, 8, 24. Add four more numbers so that mean and median of the data remain the same, but mode increases by 1.
18. If the mean of a set of observations $x_1, x_2, \dots, \dots, x_{10}$ is 20. Find the mean of $x_1 + 4, x_2 + 8, x_3 + 12, \dots, \dots, x_{10} + 40$.
19. Six numbers from a list of nine integers are 7, 8, 3, 5, 9 and 5. Find the largest possible value of the median of all nine numbers in this list.
20. The median of a set of 9 distinct observations is 20. If each of the largest 4 observations of the set is increased by 2, find the median of the resulting set.

7.2 Organisation of Grouped Data

We have learnt to organize smaller data by using tally marks in previous class. But what happens if the data is large? We organize the data by dividing it into convenient groups. It is called grouped data. Let us observe the following example.

A construction company planned to construct various types of houses for the employees based on their income levels. So they collected the data about monthly net income of the 100 employees, who wish to have a house. They are (in rupees) 15000, 15750, 16000, 16000, 16050, 16400, 16600, 16800, 17000, 17250, 17250..... 75000.

This is a large data of 100 observations, ranging from ₹ 15000 to ₹ 75000. Even if we make frequency table for each observation the table becomes large.

Instead the data can be classified into small income groups like 10001 – 20000, 20001 – 30000, ..., 70001 – 80000.

These small groups are called ‘class intervals’. The intervals 10001 – 20000 has all the observations between 10001 and 20000 including both 10001 and 20000. This form of class interval is called ‘inclusive form’, where 10001 is the ‘lower limit’, 20000 is the ‘upper limit’.

7.2.1 Interpretation of Grouped frequency distribution

Example 11: Marks of 30 students in mathematics test are given in the adjacent grouped frequency distribution.

- (i) Into how many groups the data is classified?

Sl. No.	Marks	No. of Students
1	0 – 5	5
2	5 – 10	7
3	10 – 15	10
4	15 – 20	6
5	20 – 25	2

- (ii) How many students are there in the third group?
- (iii) If a student gets 10 marks, should he be included in which class?
- (iv) What are the marks of 6 students who are in 4th class interval?
- (v) What are the individual marks of 2 students in the 5th class interval?

Answers

- (i) The data is classified into 5 groups or 5 classes.
- (ii) There are 10 students in the 3rd class interval.
- (iii) Here 10 is the upper limit of 2nd class and lower limit of 3rd class. In such case upper limit is not included in the class. So 10 is included in the 3rd class interval.
- (iv) Marks of 6 students in 4th class interval varies from 15 and below 20.
- (v) Individual marks of students can't be identified from this frequency distribution, they may be from 20 and below 25.



Do This

Ages of 90 people in an apartment are given in the adjacent grouped frequency distribution

- (i) How many Class Intervals are there in the table?
- (ii) How many people are there in the Class Interval 21-30?
- (iii) Which age group people are more in the apartment?
- (iv) Can we say that both people the last age group are of 61, 70 or any other age?

Ages	No of People
1 – 10	15
11 – 20	14
21 – 30	17
31 – 40	20
41 – 50	18
51 – 60	4
61 – 70	2

7.2.2 Limits and Boundaries

Suppose we have to organize a data of marks in a test. We make class intervals like 1-10, 11-20 ,..... If a student gets 10.5 marks, where does it fall? In class 1-10 or 11-20 ? In this situation we make use of real limits or boundaries.

Consider the class intervals shown in the table.

- Average of Upper Limit (UL) of first class and Lower Limit (LL) of second class becomes the Upper Boundary (UB) of the first class and Lower Boundary (LB) of the second class.

i.e., Average of 10, 11; $\frac{10+11}{2} = 10.5$ is the boundary.

- Now all the observations below 10.5 fall into group 1-10 and the observations from 10.5 to below 20.5 will fall into next class i.e 11-20 having boundaries 10.5 to 20.5. Thus 10.5 falls into class interval of 11-20.
- Imagine the UL of the previous class interval (usually zero) and calculate the LB of the first class interval. Average of 0, 1 is $\frac{0+1}{2} = 0.5$ is the LB. Similarly imagine the LL of the class after the last class interval and calculate the UB of the last class interval. Average of 40, 41 is $\frac{40+41}{2} = 40.5$ is the UB. These boundaries are also called “true class limits”.

Class Intervals	
Limits	Boundaries
1 – 10	0.5 - 10.5
11 – 20	10.5 – 20.5
21 – 30	20.5 – 30.5
31 – 40	30.5 – 40.5

Observe limits and boundaries for the following class intervals.

Class interval Inclusive classes	Limits		Boundaries	
	Lower limit	Upper limit	Lower boundary	Upper boundary
1-10	1	10	0.5	10.5
11-20	11	20	10.5	20.5
21-30	21	30	20.5	30.5

Class interval Exclusive classes	Limits		Boundaries	
	Lower limit	Upper limit	Lower boundary	Upper boundary
0-10	0	10	0	10
10-20	10	20	10	20
20-30	20	30	20	30

In the above illustration, we can observe that in case of discrete series (Inclusive class intervals) limit and boundaries are different. But in case of continuous series (exclusive class intervals) limits and boundaries are the same.

Difference between upper and lower boundaries of a class is called ‘**length of the class**’, represented by ‘C’.



Do These

1. Long jump made by 30 students of a class are tabulated as

Distance (cm)	101 – 200	201 – 300	301 – 400	401 – 500	501 – 600
No of students	4	7	15	3	1

- I. Are the given class intervals inclusive or exclusive?
 - II. How many students are in second class interval?
 - III. How many students jumped a distance of 3.01m or more ?
 - IV. To which class interval does the student who jumped a distance of 4.005 m belongs?
2. Calculate the boundaries of the class intervals in the above table.
 3. What is the length of each class interval in the above table?

7.2.3 Construction of grouped frequency Distribution

Consider the marks of 50 students in Mathematics secured in Summative assessment I as 31, 14, 0, 12, 20, 23, 26, 36, 33, 41, 37, 25, 22, 14, 3, 25, 27, 34, 38, 43, 32, 22, 28, 18, 7, 21, 20, 35, 36, 45, 9, 19, 29, 25, 33, 47, 35, 38, 25, 34, 38, 24, 39, 1, 10, 24, 27, 25, 18, 8.

After observing the data, you might be thinking, into how many intervals the data could be classified? How frequency distribution table could be constructed?

The following steps help in construction of grouped frequency distribution.

Step1: Find the range of the data.

$$\begin{aligned} \text{Range} &= \text{Maximum value} - \text{Minimum value} \\ &= 47 - 0 = 47 \end{aligned}$$

Step2: Decide the number of class intervals. (Generally number of class intervals are 5 to 8)

If no of class intervals = 6

$$\Rightarrow \text{Length of the class interval} = \frac{47}{6} \approx 8$$

(approximately)

Class Intervals (Marks)	Tally Marks	Frequency (No. of students)
0 – 7		4
08 – 15		6
16 – 23		9
24 – 31		13
32 – 39		14
40 – 47		4

Step 3: Write inclusive class intervals starting from minimum value of observations.
i.e 0-7, 8-15 and so on...

Step 4: Using the tally marks distribute the observations of the data into respective class intervals.

Step 5: Count the tally marks and write the frequencies in the table.

Now construct grouped frequency distribution table for exclusive classes.



Think, Discuss and Write

1. Make a frequency distribution of the following series. 1, 2, 2, 3, 3, 3, 3, 3, 4, 4, 4, 4, 4, 4, 4, 5, 5, 5, 5, 5, 5, 5, 6, 6, 6, 6, 7, 7.
2. Construct a frequency distribution for the following series of numbers.
2, 3, 4, 6, 7, 8, 9, 9, 11, 12, 12, 13, 13, 13, 14, 14, 14, 15, 16, 17, 18, 18, 19, 20, 20, 21, 22, 24, 24, 25. (Hint: Use inclusive classes)
3. What are the differences between the above two frequency distribution tables?
4. From which of the frequency distributions we can write the raw data again?

7.2.4 Characteristics of Grouped Frequency Distribution

1. It divides the data into convenient and small groups called 'class intervals'.
2. In a class interval 5-10, 5 is called lower limit and 10 is called upper limit.
3. Class intervals like 1-10, 11-20, 21-30 are called inclusive class intervals, because both lower and upper limits of a particular class belong to that particular class interval.
4. Class intervals like 0-10, 10-20, 20-30 ... are called exclusive class intervals, because only lower limit of a particular class belongs to that class, but not its upper limit.
5. Average of upper limit of a class and lower limit of the next class is called upper bound of the first class and lower bound of the next class.
6. In exclusive class intervals, both limits and boundaries are equal but in case of inclusive class intervals limits and boundaries are not equal.
7. Difference between upper and lower boundaries of a class is called 'length of the class'.
8. Individual values of all observations can't be identified from this table, but value of each observation of a particular class is assumed to be the average of upper and lower boundaries of that class. This value is called 'class mark' or 'mid value' (x).

Example 12: The following marks achieved by 30 candidates in mathematics of SSC examination held in the year 2010.

45, 56, 75, 68, 35, 69, 98, 78, 89, 90, 70, 56, 59, 35, 46, 47, 13, 29, 32, 39, 93, 84, 76, 79, 40, 54, 68, 69, 60, 59. Construct the frequency distribution table with the class intervals ; failed (0 – 34), third class (35 – 49), second class (50 – 60), first class (60 – 74) and distinction (75 – 100).

Solution: Class intervals are already given.

Step 3: Write class intervals as given.

Step 4: These are inclusive class intervals. Recall that upper limits also belong to the class. Using the tally marks, distribute the observations of the data into different class intervals.

Class Intervals (Marks)	Tally Marks	Frequency (No of students)
0 – 34		3
35 – 49		7
50 – 59		5
60 – 74		6
75 – 100		9

Step 5: Count the tally marks and write the frequencies in the table.

(**Note:** The lengths of class intervals are not same in this case)

Example 13: A grouped frequency distribution table is given below with class mark (mid values of class intervals) and frequencies. Find the class intervals.

Class marks	7	15	23	31	39	47
Frequency	5	11	19	21	12	6

Solution: We know that class marks are the mid values of class intervals. That implies class boundaries lie between every two successive class marks.

Step 1: Find the difference between two successive class marks; $h = 15 - 7 = 8$.

(Find whether difference between every two successive classes is same)

Step 2: Calculate lower and upper boundaries of every class with class mark 'x', as $x - h/2$ and $x + h/2$

For example, the upper and lower boundaries of the first class are $7 - \frac{8}{2} = 3$

and $7 + \frac{8}{2} = 11$

Class Marks	Class intervals	Frequency
7	$(7 - 4) - (7 + 4) = 03 - 11$	5
15	$(15 - 4) - (15 + 4) = 11 - 19$	11
23	$(23 - 4) - (23 + 4) = 19 - 27$	19
31	$(31 - 4) - (31 + 4) = 27 - 35$	21
39	$(39 - 4) - (39 + 4) = 35 - 43$	12
47	$(47 - 4) - (47 + 4) = 43 - 51$	6

7.3 Cumulative Frequency

In a competitive examination 1000 candidates appeared for a written test. Their marks are announced in the form of grouped frequency distribution as shown in the adjacent table. Two candidates are looking at the table and discussing like ...

Sarath: How many candidates have appeared for the test?

Sankar: It seems 1000 candidates appeared for the test.

Sarath: See, 360 candidates achieved 50-60 marks.

Sankar: If 60 is the cut off mark, how many candidates are eligible to get call letter?

Class Interval (Marks)	No of Candidates
0 - 10	25
10 - 20	45
20 - 30	60
30 - 40	120
40 - 50	300
50 - 60	360
60 - 70	50
70 - 80	25
80 - 90	10
90 - 100	5

Sarath: Do you mean how many got 60 and above marks in altogether?

Sankar: It is $50 + 25 + 10 + 5$, that is 90 candidates will be eligible.

Sarath: But there are only 105 jobs. How many candidates are eligible, if cut off mark as 50.

Sankar: In that case, $360 + 50 + 25 + 10 + 5$, that is totally 450 candidates are eligible to get call letter for interview.

Similarly we can make some more conclusions.

Number of candidates, who got equal or more than 90 (Lower boundary) = 5

Number of candidates, who got equal or more than LB of ninth CI = $10 + 5 = 15$

Number of candidates, who got equal or more than LB of eighth CI = $25 + 15 = 40$

Number of candidates, who got equal or more than LB of seventh CI = $50 + 40 = 90$

We are getting these values by taking progressive total of frequencies from either the first or last class to the particular class. These are called cumulative frequencies. The progressive sum of frequencies from the last class to the lower boundary of particular class is called 'Greater than Cumulative Frequency' (G.C.F.).

Watch out how we can write these greater than cumulative frequencies in the table.

1. Frequency in last class interval itself is greater than cumulative frequency of that class.
2. Add the frequency of the ninth class interval to the greater than cumulative frequency of the tenth class interval to give the greater than cumulative frequency of the ninth class interval
3. Successively follow the same procedure to get the remaining greater than cumulative frequencies.

Class Interval (Marks)	LB	Frequency (No of Candidates)	Greater than cumulative frequency
0 – 10	0	25	$25+975 = 1000$
10 – 20	10	45	$45+930 = 975$
20 – 30	20	60	$60+870 = 930$
30 – 40	30	120	$120+750 = 870$
40 – 50	40	300	$300+450 = 750$
50 – 60	50	360	$360+ 90 = 450$
60 – 70	60	50	$50 + 40 = 90$
70 – 80	70	25	$25 + 15 = 40$
80 – 90	80	10	$10 + 5 = 15$
90 – 100	90	5	5

The distribution that represent lower boundaries of the classes and their respective Greater than cumulative frequencies is called Greater than Cumulative Frequency Distribution .

Similarly in some cases we need to calculate less than cumulative frequencies.

For example if a teacher wants to give some extra support for those students, who got less marks than a particular level, we need to calculate the less than cumulative frequencies.

Thus the progressive total of frequencies from first class to the upper boundary of a particular class is called Less than Cumulative Frequency (L.C.F.).

Class Interval (Marks)	UB	No. of Candidates frequency	Less than cumulative frequency
0 – 5	5	7	7
5 – 10	10	10	$10+7 = 17$
10 – 15	15	15	$15+17 = 32$
15 – 20	20	8	$8+32 = 40$
20 – 25	25	3	$3+40 = 43$

Consider the grouped frequency distribution expressing the marks of 43 students in a unit test.

1. Frequency in first class interval is directly written into less than cumulative frequency.
2. Add the frequency of the second class interval to the less than cumulative frequency of the first class interval to give the less than cumulative frequency of the second class interval.

3. Successively follow the same procedure to get remaining less than cumulative frequencies.

The distribution that represents upper boundaries of the classes and their respective less than cumulative frequencies is called Less than Cumulative Frequency Distribution.



Try These

- Less than cumulative frequency is related to _____
- Greater than cumulative frequency is related to _____
- Write the Less than and Greater than cumulative frequencies for the following data

Class Interval	1 - 10	11 - 20	21 - 30	31 - 40	41 - 50
Frequency	4	7	12	5	2

- What is total frequency and less than cumulative frequency of the last class in the above problem? What do you infer?

Example 14: Given below are the marks of students in a less than cumulative frequency distribution table. Write the frequencies of the respective classes. Also write the Greater than cumulative frequencies. How many students' marks are given in the table?

Class Interval (Marks)	1 - 10	11 - 20	21 - 30	31 - 40	41 - 50
L.C.F. (No of students)	12	27	54	67	75

Solution:

Class Interval (Marks)	L.C.F.	Frequency (No of students)	G.C.F.
1 - 10	12	12	$12 + 63 = 75$
11 - 20	27	$27 - 12 = 15$	$15 + 48 = 63$
21 - 30	54	$54 - 27 = 27$	$27 + 21 = 48$
31 - 40	67	$67 - 54 = 13$	$13 + 8 = 21$
41 - 50	75	$75 - 67 = 8$	8

Total number of students mentioned in the table is nothing but total of frequencies or less than cumulative frequency of the last class or greater than cumulative frequency of the first class interval, i.e. 75.



Exercise - 7.2

1. Given below are the ages of 45 people in a colony.

33 8 7 25 31 26 5 50 25 48 56
33 28 22 15 62 59 16 14 19 24 35
26 9 12 46 15 42 63 32 5 22 11
42 23 52 48 62 10 24 43 51 37 48
36

Construct grouped frequency distribution for the given data with 6 class intervals.

2. Number of students in 30 class rooms in a school are given below. Construct a frequency distribution table for the data with an exclusive class interval of 4 (students).

25 30 24 18 21 24 32 34 22 20 22
32 40 28 30 22 26 31 34 15 38 28
20 16 15 20 24 30 25 18

3. Class intervals in a grouped frequency distribution are given as 4 – 11, 12 – 19, 20 – 27, 28 – 35, 36 – 43. (i) Write the next two class intervals. (ii) Write the class boundaries of all classes.

4. In the following grouped frequency distribution table class marks are given.

Class Marks	10	22	34	46	58	70
Frequency	6	14	20	21	9	5

- (i) Construct class intervals of the data. (Exclusive class intervals)
(ii) Construct less than cumulative frequencies and
(iii) Construct greater than cumulative frequencies.
5. The marks obtained by 35 students in a test in statistics (out of 50) are as below.

35 1 15 35 45 23 31 40 21 13 15
20 47 48 42 34 43 45 33 37 11 13
27 18 12 37 39 38 16 13 18 5 41
47 43

Construct a frequency distribution table with equal class intervals, one of them being 10-20 (20 is not included).

6. Construct the class boundaries for the following frequency distribution table. Also construct less than cumulative and greater than cumulative frequency tables.

Ages	1 - 3	4 - 6	7 - 9	10 - 12	13 - 15
No. of children	10	12	15	13	9

7. Cumulative frequency table is given below. Which type of cumulative frequency is given. Try to build the frequencies of respective class intervals.

Runs	0 - 10	10 - 20	20 - 30	30 - 40	40 - 50
No. of cricketers	3	8	19	25	30

8. Number of readers in a library are given below. Write the frequency of respective classes. Also write the less than cumulative frequency table.

Number of books	1-10	11-20	21-30	31-40	41-50
Greater than Cumulative frequency	42	36	23	14	6

7.4 Graphical Representation of Data

Frequency distribution is an organised data with observations or class intervals with frequencies. We have already studied how to represent of discrete series in the form of pictographs, bar graphs, double bar graph and pie charts.

Let us recall bar graph first.

7.4.1 Bar Graph

A display of information using vertical or horizontal bars of uniform width and different lengths being proportional to the respective values is called a bar graph.

Let us see what a bar graph can represent. Study the following vertical bar graph.

- What does this bar graph represent?
- How many students secured A, B or C grades?

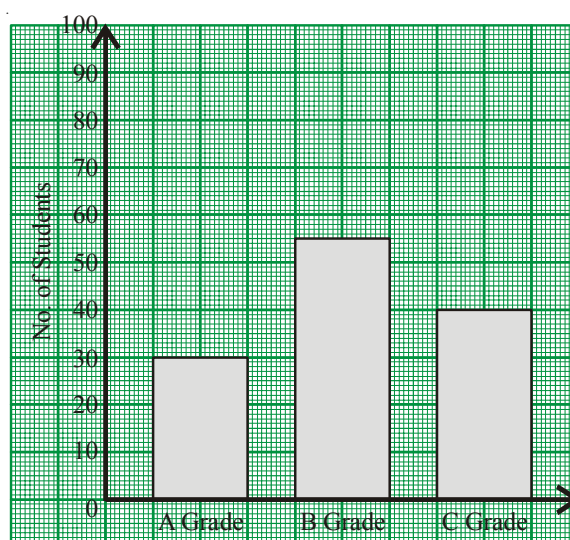

Acheivement in exam

(iii) Which grade is secured by more number of the students?

(iv) How many students are there in the class?

It is easy to answer the questions from the graph

Similarly in some graphs bars may be drawn horizontally. For example observe the second bar graph. It gives the data about number of vehicles in a village Sangam in Nellore district.

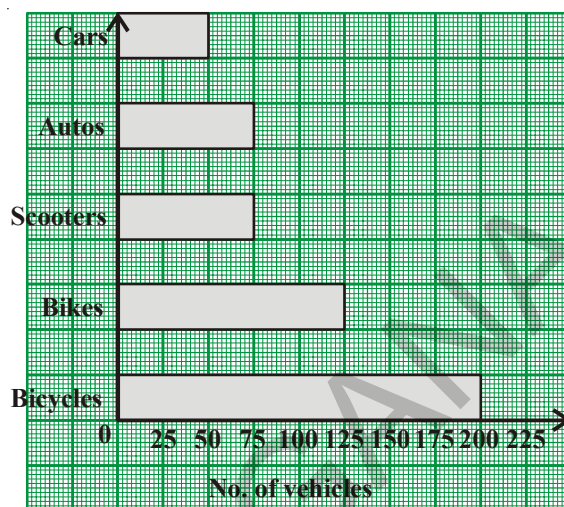

Think, Discuss and Write

- All the bars (or rectangles) in a bar graph have _____.
(a) same length (b) same width (c) same area (d) equal value
- Does the length of each bar depend on the lengths of other bars in the graphs?
- Does the variation in the value of a bar affect the values of other bars in the same graph?
- Where do we use vertical bar graphs and horizontal bar graphs.

7.5 Graphical Representation of Grouped Frequency Distribution

Let us learn the graphical representation of grouped frequency distributions of continuous series i.e. with exclusive class intervals. First one of its kind is histogram.

7.5.1 Histogram

7.5.1.1 Interpretation of Histogram

Observe the following histogram for the given grouped frequency distribution and answer the given questions.

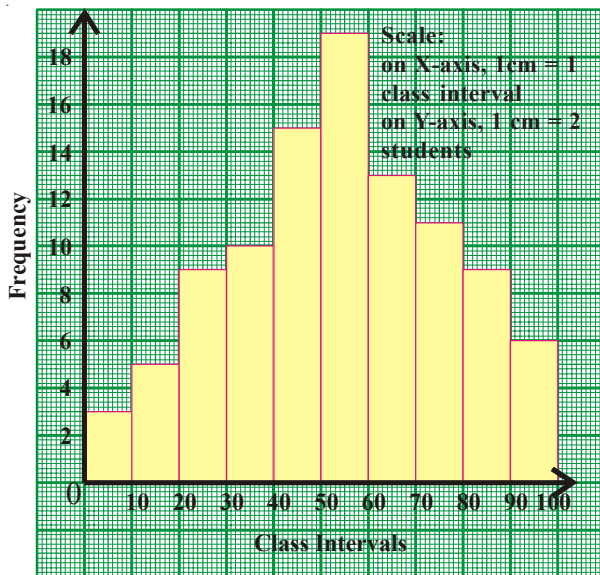

Class Interval (Marks)	Frequency (No of Students)
0 – 10	3
10 – 20	5
20 – 30	9
30 – 40	10
40 – 50	15
50 – 60	19
60 – 70	13
70 – 80	11
80 – 90	9
90 -100	6

- How many bars are there in the graph?
- In what proportion the height of the bars are drawn?
- Width of all bars is same. What may be the reason?
- Shall we interchange any two bars of the graph?

From the graph you might have understood that

- There are 10 bars representing frequencies of 10 class intervals.
- Heights of the bars are proportional to the frequencies,
- Width of bars is same because width represents the class interval. Particularly in this example length of all class intervals is same.
- As it is representing a continuous series, (with exclusive class intervals), we can't interchange any two bars.



Try These

Observe the adjacent histogram and answer the following questions-

- What information is being represented in the histogram?
- Which group contains maximum number of students?
- How many students watch TV for 5 hours or more?
- How many students are surveyed in total?

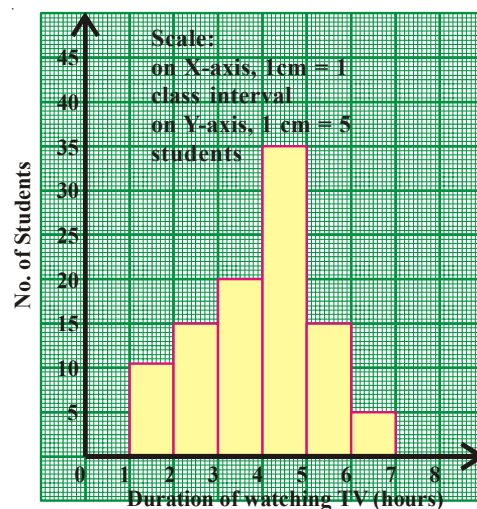

7.5.1.2 Construction of a Histogram

A TV channel wants to find which age group of people are watching their channel. They made a survey in an apartment. Represent the data in the form of a histogram.

Step 1 : If the class intervals given are inclusive (limits) convert them into the exclusive form (boundaries) since the histogram has to be drawn for a continuous series.

Class Interval (Age group)	Frequency (No of viewers)	Class Intervals
11 – 20	10	10.5 – 20.5
21 – 30	15	20.5 – 30.5
31 – 40	25	30.5 – 40.5
41 – 50	30	40.5 – 50.5
51 – 60	20	50.5 – 60.5
61 – 70	5	60.5 – 70.5
Limits		Boundaries

Step 2 : Choose a suitable scale on the X-axis and mark the class intervals on it.

Step 3 : Choose a suitable scale on the Y-axis and mark the frequencies on it. (The scales on both the axes may not be same)

Scale : X-axis 1 cm = one class interval
Y-axis 1 cm = 5 people

Step 4 : Draw rectangles with class intervals as bases and the corresponding frequencies as the corresponding heights.

Scale :
x - axis : 1 cm = 1 class interval
y - axis : 1 cm = 5 people

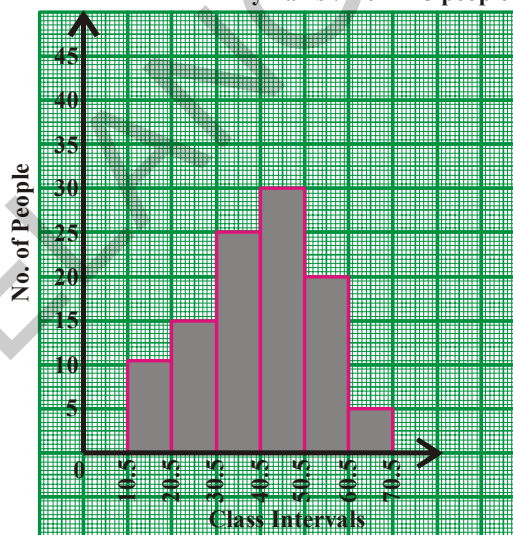

7.5.1.3 Histogram with Varying Base Widths

Consider the following frequency distribution table.

Category	Class Intervals (Marks)	Percentage of Students
Failed	0-35	28
Third Class	35-50	12
Second Class	50-60	16
First Class	60-100	44

You have noticed that for different categories of children performance the range of marks for each category is not uniform. If we observe the table, the students who secured first class is 44 % which spreads over the class length 40 (60 to 100). Where as the student who have secured second class is 16% of the students spread over the class length 10 (50 to 60) only. Therefore to represent the above distribution table into histogram we have take the widths of class intervals also into account.

In such cases frequency per unit class length (frequency density) has to be calculated and histogram has to be constructed with respective heights. Any class interval may be taken as unit class interval for calculating frequency density. For convenience least class length is taken as unit class length.

∴ Modified length of any rectangle is proportional to the corresponding frequency

$$\text{Density} = \frac{\text{Frequency of class}}{\text{Length of that class}} \times \text{Least class length}$$

Class intervals (Marks)	Percentage of students	Class length	Length of the rectangle
0 – 35	28	35	$\frac{28}{35} \times 10 = 8$
35 – 50	12	15	$\frac{12}{15} \times 10 = 8$
50 – 60	16	10	$\frac{16}{10} \times 10 = 16$
60 – 100	44	40	$\frac{44}{40} \times 10 = 11$

With the modified lengths histogram has to be constructed as in the previous example.

Step 1: Choose a suitable scale on the X-axis and mark the class intervals on it.

Step 2: Choose a suitable scale on the Y-axis and mark the frequencies on it. (The scales on both the axes may not be same)

Scale: X-axis 1 cm = 1 Min. class interval

Y-axis 1 cm = 2 %

Step 3: Draw rectangles with class intervals as bases and the corresponding frequencies as the heights.

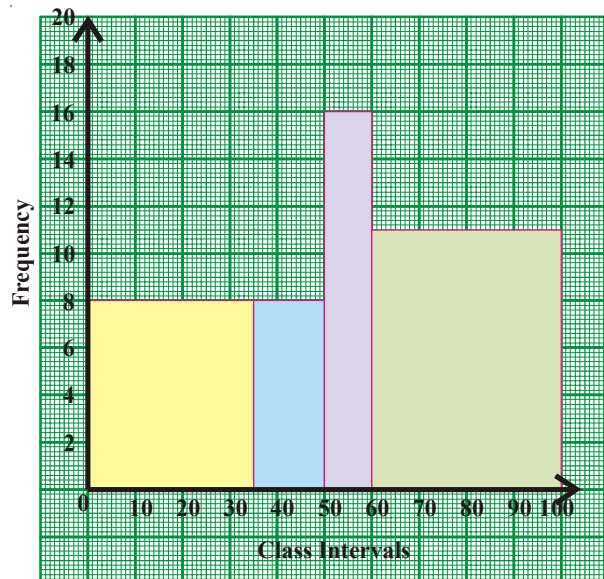

7.5.1.4 Histogram for grouped frequency distribution with class marks

Example 15: Construct a histogram from the following distribution of total marks obtained by 65 students of class VIII.

Marks (Mid points)	150	160	170	180	190	200
No. of students	8	10	25	12	7	3

Solution: As class marks (mid points) are given, class intervals are to be calculated from the class marks.

Step 1: Find the difference between two successive classes. $h = 160 - 150 = 10$.

(Find whether difference between every two successive classes is same)

Step 2: Calculate lower and upper boundaries of every class with class mark 'x', as $x - \frac{h}{2}$ and $x + \frac{h}{2}$.

Step 3: Choose a suitable scale. X-axis 1 cm = one class interval

Y-axis 1cm = 4 students

Step 4: Draw rectangles with class intervals as bases and the corresponding frequencies as the heights.

Class Marks (x)	Class Intervals	Frequency (No of students)
150	145 – 155	8
160	155 – 165	10
170	165 – 175	25
180	175 – 185	12
190	185 – 195	7
200	195 – 205	3

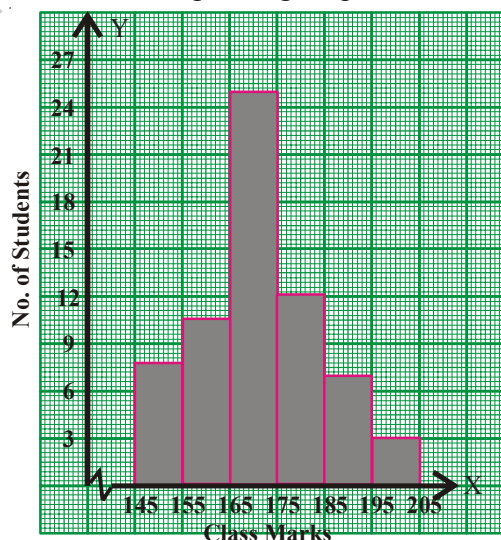

Think, Discuss and Write

1. Class boundaries are taken on the 'X' - axis. Why not class limits?
2. Which value decides the width of each rectangle in the histogram?
3. What does the sum of heights of all rectangles represent?

7.5.2 Frequency Polygon

7.5.2.1 Interpretation of Frequency Polygon

Frequency polygon is another way of representing a quantitative data and its frequencies. Let us see the advantages of this graph.

Consider the adjacent histogram representing weights of 33 people in a company. Let us join the mid-points of the upper sides of the adjacent rectangles of this histogram by means of line segments. Let us call these mid-points B, C, D, E, F and G. When joined by line segments, we obtain the figure BCDEFG. To complete the polygon, we assume that there is a class interval with frequency zero before 30.5-35.5 and one after 55.5 - 60.5, and their mid-points are A and H, respectively. ABCDEFGH is the frequency polygon.

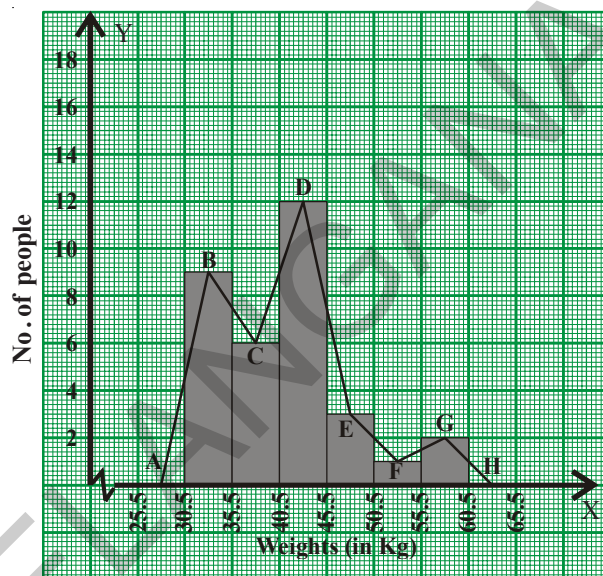

Although, there exists no class preceding the lowest class and no class succeeding the highest class, addition of the two class intervals with zero frequency enables us to make the area of the frequency polygon the same as the area of the histogram. Why is this so?



Think, Discuss and Write

1. How do we complete the polygon when there is no class preceding the first class?
2. The area of histogram of a data and its frequency polygon are same. Reason how.
3. Is it necessary to draw histogram for drawing a frequency polygon?
4. Shall we draw a frequency polygon for frequency distribution of discrete series?

7.5.2.2 Construction of a Frequency Polygon

Consider the marks, (out of 25), obtained by 45 students of a class in a test. Draw a frequency polygon corresponding to this frequency distribution table.

Class Interval (Marks)	Frequency (No. of students)	Mid Values
0-5	7	2.5
5-10	10	7.5
10-15	14	12.5
15-20	8	17.5
20-25	6	22.5
Total	45	

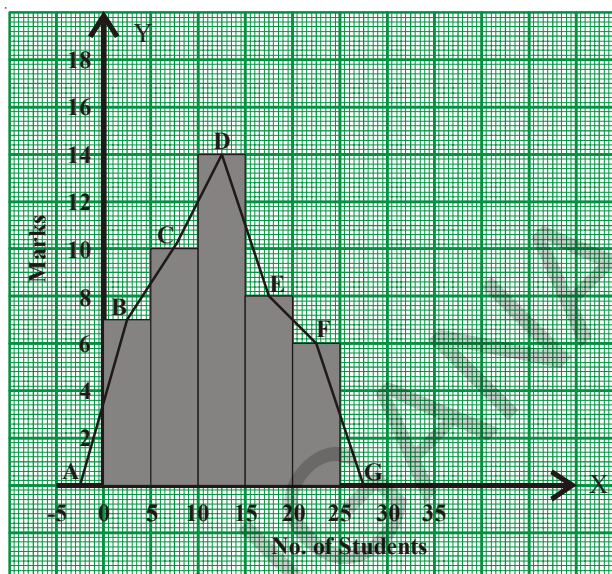

Steps of construction

- Step 1: Calculate the mid points of every class interval given in the data.
- Step 2: Draw a histogram for this data and mark the mid-points of the tops of the rectangles (here in this example B, C, D, E, F respectively).
- Step 3: Join the mid points successively.
- Step 4: Assume a class interval before the first class and another after the last class. Also calculate their mid values (A and H) and mark on the axis. (Here, the first class is 0 – 5. So, to find the class preceding 0 - 5, we extend the horizontal axis in the negative direction and find the mid-point of the imaginary class-interval $-5 - 0$)
- Step 5: Join the first end point B to A and last end point F to G which completes the frequency polygon.

Frequency polygon can also be drawn independently without drawing histogram. For this, we require the midpoints of the class interval of the data.



Do These

1. Construct the frequency polygons of the following frequency distributions.

(i) Runs scored by students of a class in a friendly cricket match.

Runs scored	10 – 20	20 – 30	30 – 40	40 – 50	50 – 60
No. of students	3	5	8	4	2

(ii) Sale of tickets for drama in an auditorium.

Rate of ticket	10	15	20	25	30
No. of tickets sold	50	30	60	30	20

7.5.2.3 Characteristics of a Frequency Polygon:

1. Frequency polygon is a graphical representation of a frequency distribution (discrete / continuous)
2. Class marks or Mid values of the successive classes are taken on X-axis and the corresponding frequencies on the Y-axis.
3. Area of frequency polygon and histogram drawn for the same data are equal.



Think, Discuss and Write

1. Histogram represents frequency over a class interval. Can it represent the frequency at a particular point value?
2. Can a frequency polygon give an idea of frequency of observations at a particular point?

7.5.2.4 Construction of a Frequency Polygon for a grouped frequency distribution (without using histogram):

In a study of diabetic patients, the following data were obtained.

Ages	10 – 20	20 – 30	30 – 40	40 – 50	50 – 60
No. of patients	5	9	16	11	3

Let us construct frequency polygon for it without using the histogram.

Step 1: Find the class marks of different classes.

Step 2: Select the scale :

X-axis 1 cm = 1 class interval

Y-axis 1 cm = 2 marks

Step 3: If 'x' denotes the class mark and f denotes the corresponding frequency of a particular class, then plot ('x', f) on the graph.

Step 4: Join the consecutive points in order by line segments.

Step 5: Imagine two more classes, one before the first class and the other after the last class each having zero frequency. Mark their mid values on the graph.

Step 6: Complete the polygon.

Class Interval (Ages)	No. of Patients	Class Mark	Points
0 – 10	0	5	(5, 0)
10 – 20	5	15	(15, 5)
20 – 30	9	25	(25, 9)
30 – 40	16	35	(35, 16)
40 – 50	11	45	(45, 11)
50 – 60	3	55	(55, 3)
60 – 70	0	65	(65, 0)

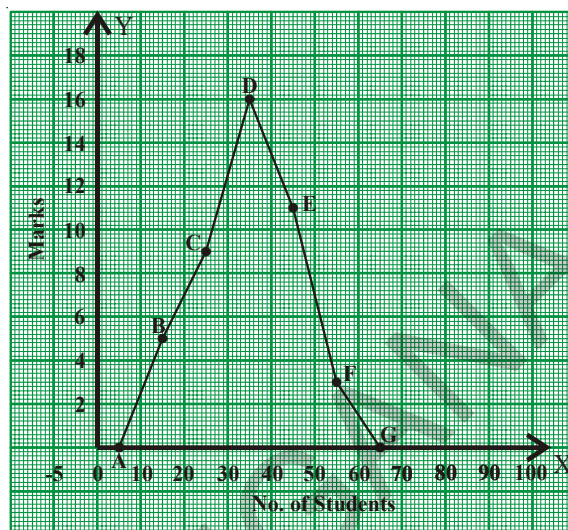

7.5.3 Frequency Curve for a grouped frequency distribution

It is another way of representation of the data by a free hand curve.

Let us construct frequency curve for the above data without using the histogram.

Step 1: Find the class marks of different classes.

Step 2: Select the scale :

X-axis 1 cm = 1 class interval

Y-axis 1 cm = 2 marks

Step 3: If 'x' denotes the class mark and f denotes the corresponding frequency of a particular class, then plot (x, f) on the graph.

Step 4: Join the consecutive points successively by a free hand curve.

Class Interval (Ages)	No. of Patients	Class Mark	Points
0 – 10	0	5	(5, 0)
10 – 20	5	15	(15, 5)
20 – 30	9	25	(25, 9)
30 – 40	16	35	(35, 16)
40 – 50	11	45	(45, 11)
50 – 60	3	55	(55, 3)
60 – 70	0	65	(65, 0)

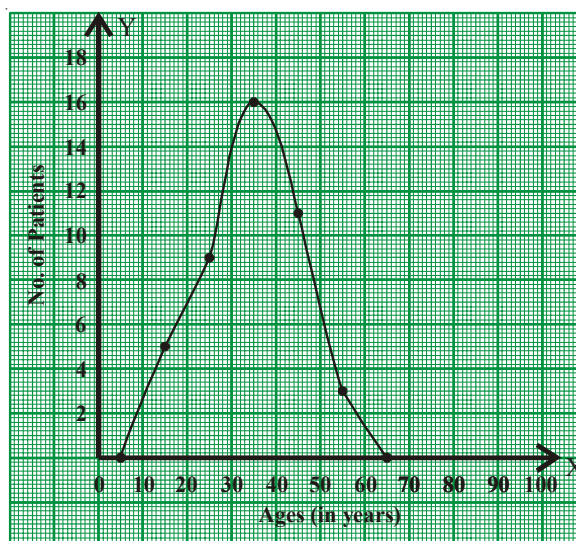

7.5.4 Graph of a Cumulative Frequency Distribution

A graph representing the cumulative frequencies of a grouped frequency distribution against the corresponding lower / upper boundaries of respective class intervals is called Cumulative Frequency Curve or Ogive Curve. These curves are useful in understanding the accumulation or outstanding number of observations at every particular level of continuous series.

7.5.4.1 Less than Cumulative frequency curve

Consider the grouped frequency distribution of number of tenders received by a department from the contractors for a civil work in a course of time.

Class (days)	0 – 4	4 - 8	8 - 12	12 – 16	16 – 20
No. of tenders	2	5	12	10	3

Step 1: If the given frequency distribution is in inclusive form, then convert it into an exclusive form.

Step 2: Construct the less than cumulative frequency table.

Step 3: Mark the upper boundaries of the class intervals along X-axis and their corresponding cumulative frequencies along Y-axis

Select the scale :

X-axis 1 cm = 1 class interval

Y-axis 1 cm = 4 tenders

Step 4: Also, plot the lower boundary of the first class (upper boundary of the class previous to first class) interval with cumulative frequency 0.

Step 5: Join these points by a free hand curve to obtain the required ogive.

Similarly we can construct 'Greater than cumulative frequency curve' by taking greater than cumulative on Y-axis and corresponding 'Lower Boundaries' on the X-axis.

Class Interval (Days)	No. of Tenders	UB	L.Cu.Fr
0 – 4	2	4	2
4 – 8	5	8	7
8 – 12	12	12	19
12 – 16	10	16	29
16 – 20	3	20	32

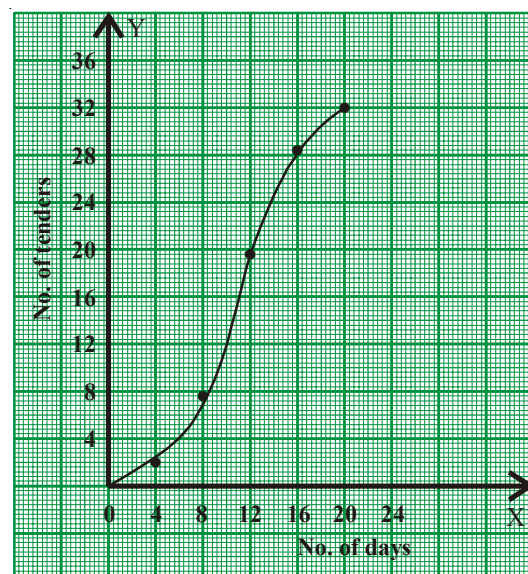



Exercise - 7.3

1. The following table gives the distribution of 45 students across the different levels of Intelligent Quotient. Draw the histogram for the data.

Class (IQ)	60-70	70-80	80-90	90-100	100-110	110-120	120-130
No. of students	2	5	6	10	9	8	5

2. Construct a histogram for the marks obtained by 600 students in the VII class annual examinations.

Marks	360	400	440	480	520	560
No. of students	100	125	140	95	80	60

3. Weekly wages of 250 workers in a factory are given in the following table. Construct the histogram and frequency polygon on the same graph for the data given.

Weekly wage	500-550	550-600	600-650	650-700	700-750	750-800
No. of workers	30	42	50	55	45	28

4. Ages of 60 teachers in primary schools of a Mandal are given in the following frequency distribution table. Construct the Frequency polygon and frequency curve for the data without using the histogram. (Use separate graph sheets)

Ages	24 – 28	28 – 32	32 – 36	36 – 40	40 – 44	44 – 48
No. of teachers	12	10	15	9	8	6

5. Construct class intervals and frequencies for the following distribution table. Also draw the ogive curves for the same.

Marks obtained	Less than 5	Less than 10	Less than 15	Less than 20	Less than 25
No. of students	2	8	18	27	35



What we have discussed

1. Arithmetic mean of the ungrouped data = $\frac{x_1 + x_2 + x_3 + \dots + x_n}{n}$ or $\bar{x} = \frac{\sum x_i}{N}$
(short representation) where $\sum x_i$ represents the sum of all x_i s where 'i' takes the values from 1 to n
2. Arithmetic mean = Estimated mean + Average of deviations
Or $\bar{x} = A + \frac{\sum(x_i - A)}{N}$
3. Mean is used in the analysis of numerical data and is represented by a unique value.
4. Median represents the middle value of the distribution arranged in either ascending or descending order.
5. The median is used to analyse the numerical data, particularly useful when there are a few observations that are unlike mean, it is not affected by extreme values.
6. Mode is used to analyse both numerical and verbal data.
7. Mode is the most frequent observation of the given data. There may be more than one mode for the given data.
8. Representation of classified distinct observations of the data with frequencies is called 'Frequency Distribution' or 'Distribution Table'.
9. Difference between upper and lower boundaries of a class is called length of the class denoted by 'C'.
10. In a class the initial value and end value of each class is called the lower limit and upper limit respectively of that class.
11. The average of upper limit of a class and lower limit of successive class is called upper boundary of that class.
12. The average of the lower limit of a class and upper limit of preceding class is called the lower boundary of the class.
13. The progressive total of frequencies from the last class of the table to the lower boundary of particular class is called Greater than Cumulative Frequency (G.C.F).
14. The progressive total of frequencies from first class to the upper boundary of particular class is called Less than Cumulative Frequency (L.C.F).



15. Histogram is a graphical representation of frequency distribution of exclusive class intervals.
16. When the class intervals in a grouped frequency distribution are varying we need to construct rectangles in histogram on the basis of frequency density.

$$\text{Frequency density} = \frac{\text{Frequency of class}}{\text{Length of that class}} \times \text{Least class length in the data}$$

17. Frequency polygon is a graphical representation of a frequency distribution (discrete / continuous)
18. In frequency polygon or frequency curve, class marks or mid values of the classes are taken on X-axis and the corresponding frequencies on the Y-axis.
19. Area of frequency polygon and histogram drawn for the same data are equal.
20. A graph representing the cumulative frequencies of a grouped frequency distribution against the corresponding lower / upper boundaries of respective class intervals is called Cumulative Frequency Curve or “Ogive Curve”.

Thinking Critically

The ability of some graphs and charts to distort data depends on perception of individuals to figures. Consider these diagrams and answer each question both before and after checking.

- (a) Which is longer, the vertical or horizontal line?
- (b) Are lines l and m straight and parallel?
- (c) Which line segment is longer : \overline{AB} or \overline{BC}
- (d) How many sides does the polygon have? Is it a square?
- (e) Stare at the diagram below. Can you see four large posts rising up out of the paper? State some and see four small posts.

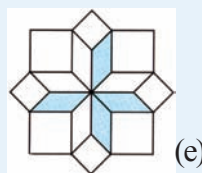
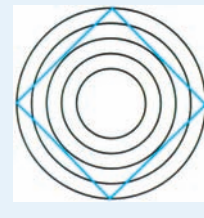
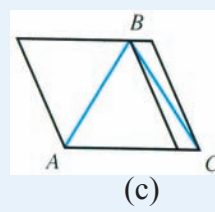
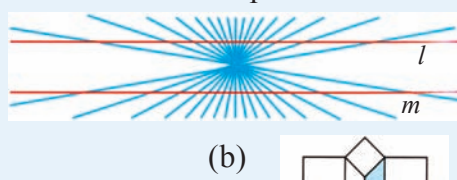
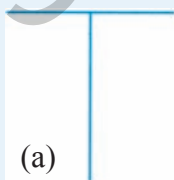



8.0 Introduction

We come across various figures of geometry in our daily life. There are many objects that have direct or indirect connection with geometry. These objects or actions have geometrical properties and applications. Look at the following pictures. Observe are the various geometrical figures and patterns involved in it. You might have found some shapes are similar in nature, some are congruent and some geometrical patterns that are evenly spread on the floor.

Can you identify such congruent shapes, similar shapes and symmetric shapes or patterns in the pictures?



The shapes of windows in the picture are congruent. The triangular elevations are similar and the tile patterns that are spread on the floor are of symmetric figures.

Let us study how these principles of geometrical shapes and patterns are influencing our daily life.

8.1 Congruency

You might have seen various objects with same size and shape which we use in our daily life. For example blades of a fan are of same shape and size.



Another example for congruency of shapes in daily life.

Go to an audio shop and find a Compact Disc (CD) there, what do you notice? The CDs are of same size and shape. If you place them one above the other, they cover each other exactly. We can say that the faces of CDs are congruent to one another. Now put the post cards one above the other. You will find that all post cards have same size and shape; they are all congruent to one another.

Name any three objects with congruent faces.

8.1.1 Congruency of shapes

Observe the following

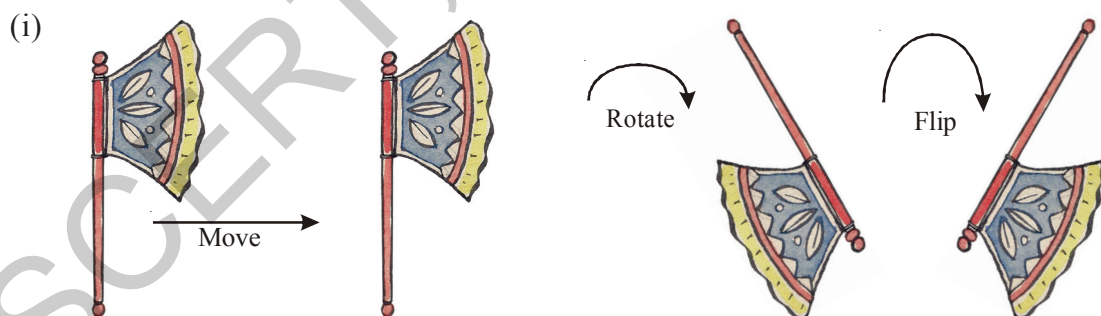

In the above pictures, do all the figures represent the same object irrespective of their position?

Here the same figure is moved, rotated and flipped to get figures. They represent the same hand fan.

If we place all figures one above the other, what do you find?

They all cover each other exactly i.e. they have same shape and size.

What do we call the figures with same shape and size ?

Figures with same shape and size are called congruent figures.

Flip : Flip is a transformation in which a plane figure is reflected across a line, creating a mirror image of the original figure.



After a figure is flipped or reflected, the distance between the line of reflection and each point on the original figure is the same as the distance between the line of reflection and the corresponding point on the mirror image.

Rotation : "Rotation" means turning around a center. The distance from the center to any point on the shape stays the same. Every point makes a circle around the center.

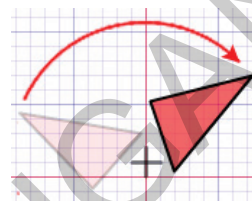

There is a central point that stays fixed and everything else moves around that point in a circle. A "Full Rotation" is 360°

Now observe the following geometrical figures.

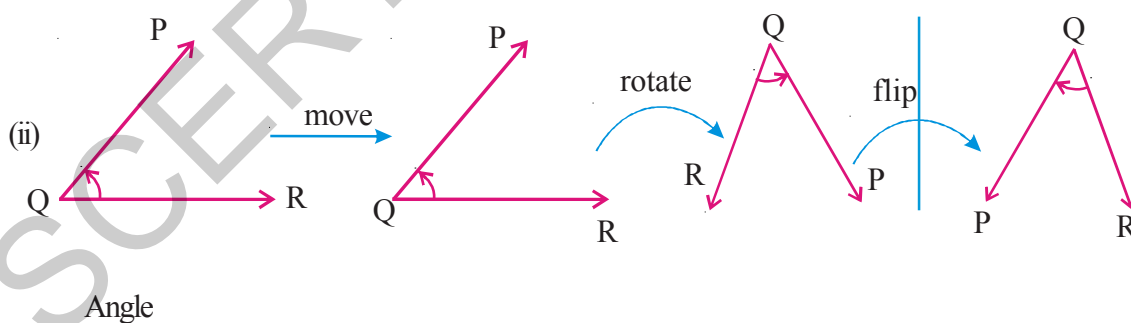
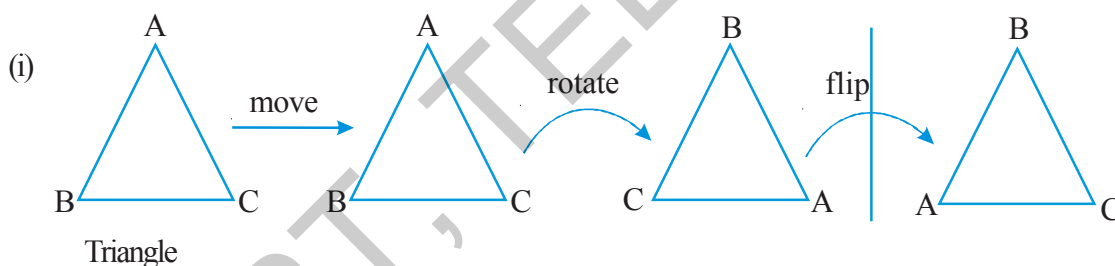

In all the cases, if the first figure in the row is moved, rotated and flipped do you find any change in size and shape? No, the figures in every row are congruent, they represent the same figure but oriented differently.

If two shapes are congruent, still they remain congruent, even they are moved or rotated. The shapes would also remain congruent if we reflect the shapes by producing their mirror images.

We use the symbol \cong to represent congruency.



Do This

Identify which of the following pairs of figures are congruent.

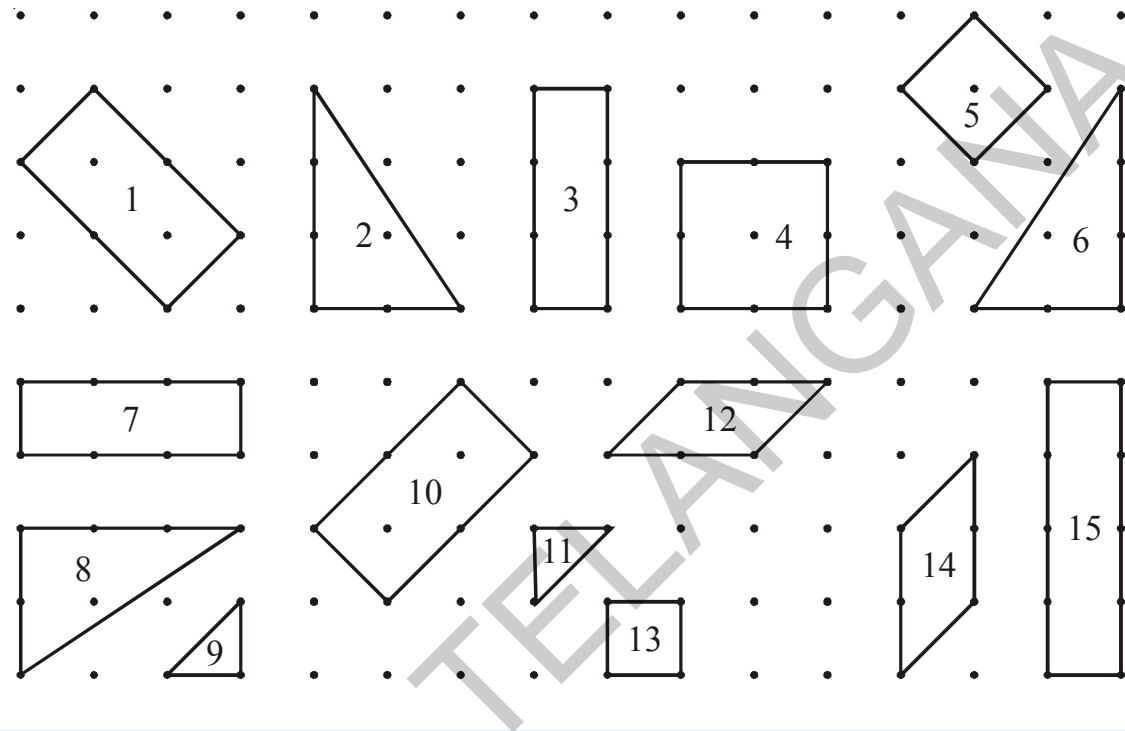

Can you say when do a pair of (a) Line segments (b) angles and (c) triangles are congruent?

(a) We know that two line segments are congruent if they have same lengths.



Length of AB = length of PQ then $AB \cong PQ$

(b) Two angles are congruent if they have same measure.

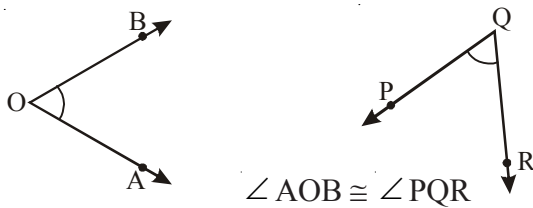

$\angle AOB \cong \angle PQR$

(c) Two triangles $\triangle ABC$ and $\triangle PQR$ are congruent if their corresponding sides and angles are equal.

i.e. $AB = PQ$ and $\angle A = \angle P$
 $BC = QR$ $\angle B = \angle Q$
 $CA = RP$ $\angle C = \angle R$

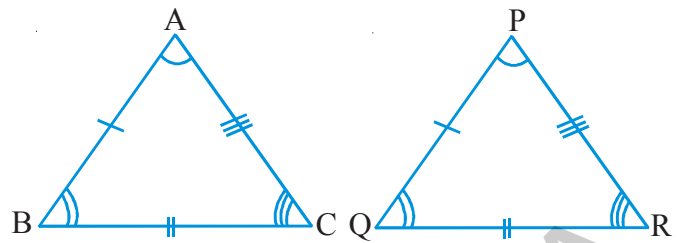

$\triangle ABC \cong \triangle PQR$.

Now, how can you say that two polygons are congruent?

Let us discuss this with an example. Let us consider ABCD and PQRS. If we place one square (i.e.) ABCD on the other i.e. PQRS, they should cover each other exactly

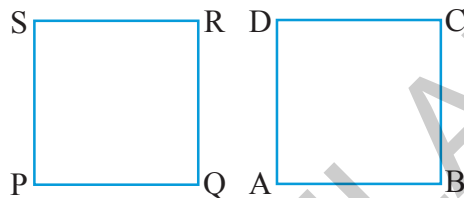

i.e. the edges must coincide with each other, only then we say that the two squares are congruent.

"If two polygons are congruent then their corresponding sides are equal and corresponding angles are equal. Thus the two geometrical shapes are said to be congruent if they coincide with each other exactly."

Do This

Look at the following pairs of figures and find whether they are congruent. Give reasons.

(i)

(ii)

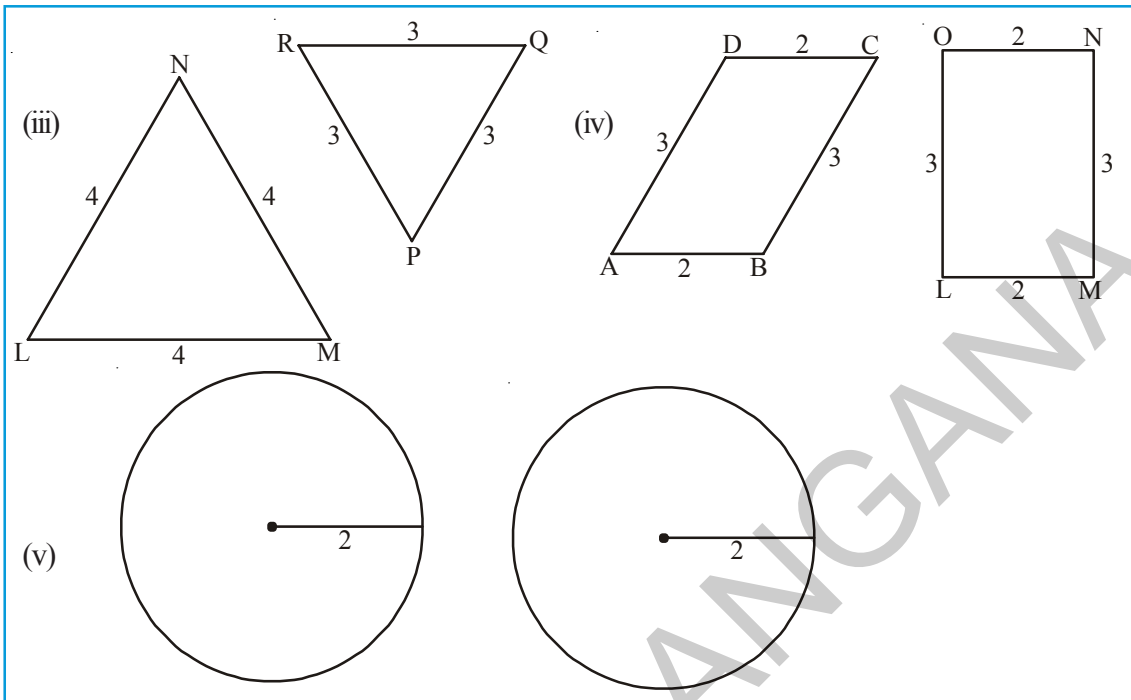





8.1.2 Similar shapes

In our books, we have pictures of many objects from our surroundings. For example pictures of elephants, tigers, elevation plan of a huge building, block diagram of a microchip etc.





Are they drawn to their original size? No, it is not possible. Some of them are drawn smaller than the real object and some of them are drawn larger.

Do This

1. Identify the out line figures which are similar to the first figure.

(a)    

(i) (ii) (iii)

(b)    

(i) (ii) (iii)

A picture of a tree is drawn on a paper. How do you say the picture drawn is similar to its original?



Tree

Picture

Here is an object is shown which is reduced in different proportions. Which of the following reductions resembles the original object?

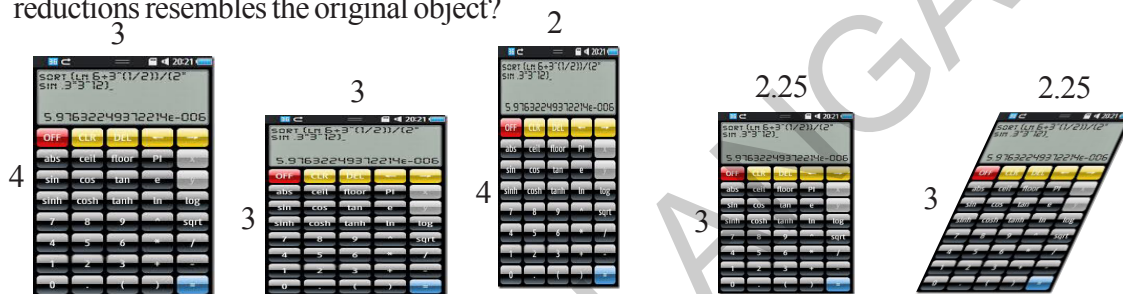

Original object

Reduction -1

Reduction -2

Reduction -3

Reduction -4

By comparing the dimensions, we say that reduction-3 resembles the original object. Why?

Let us, find the ratio of corresponding sides of original object and reduction -3, what do you notice?

$$\frac{\text{Length of the original}}{\text{length of the reduction-3}} = \frac{4}{3}$$

$$\frac{\text{breadth of the original}}{\text{breadth of the reduction-3}} = \frac{3}{2.25} = \frac{3 \times 4}{2.25 \times 4} = \frac{12}{9} = \frac{4}{3}$$

We notice that the ratios of corresponding sides are equal.

Here all the corresponding angles are right angles and are equal.

Hence we conclude that “two polygons are similar if their corresponding angles are congruent and lengths of corresponding sides are proportional”.

Find the ratio of corresponding sides for all other reductions.

8.1.3 Where do we find the application of similarity?

Engineers draw elevation plans, similar to the building to be constructed. D.T.P operators draw diagrams on the computer which can be magnified in proportion to make banners. Photographer makes photo image prints of the same by enlarging or reducing without distortion based on principle of proportion. Diagrams of science apparatus and maps in social studies that you have come across are in proportion i.e. similar to the original objects.

Checking the similarity

Observe the following pairs of similar figures. Measure their sides and find the ratio between their corresponding sides, also find the corresponding angles. What do you observe?

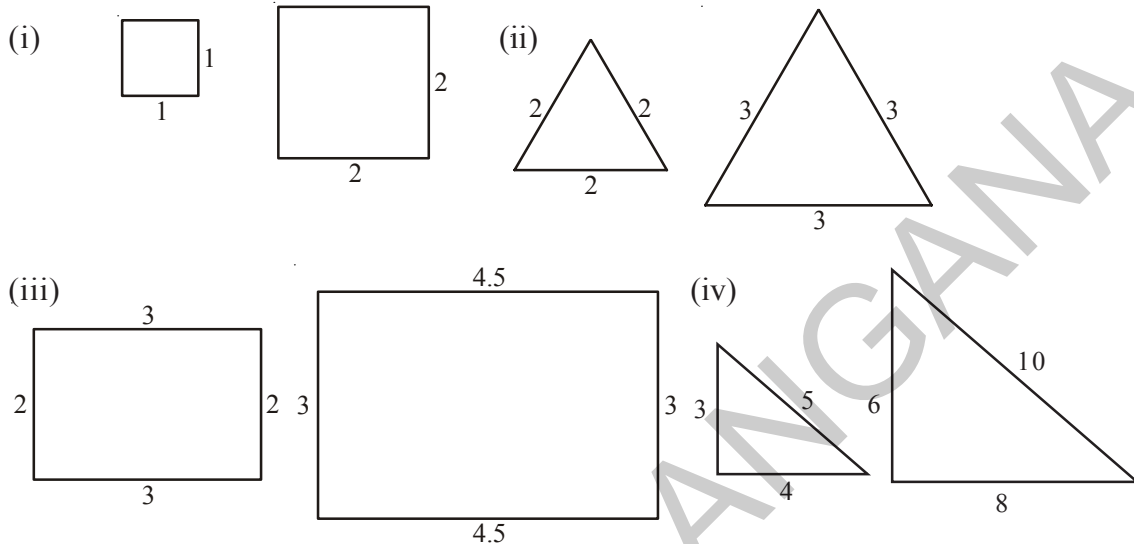

Complete the table based on the figures given above

Ratio of corresponding sides	Corresponding angles
(i) Square = $\frac{1}{2} = \frac{1}{2}$	$(90^\circ, 90^\circ, 90^\circ, 90^\circ) = (90^\circ, 90^\circ, 90^\circ, 90^\circ)$
(ii) Equilateral triangle = $\frac{2}{3} = \frac{2}{3} = \frac{2}{3}$	$(60^\circ, 60^\circ, 60^\circ) = (60^\circ, 60^\circ, 60^\circ)$
(iii) Rectangle = $\frac{2}{3} = \dots\dots\dots$	$(90^\circ, 90^\circ, 90^\circ, 90^\circ) = (90^\circ, 90^\circ, 90^\circ, 90^\circ)$
(iv) Right angled triangle = $\frac{3}{6} = \dots\dots\dots$	$(\dots\dots\dots, \dots\dots\dots, \dots\dots\dots) = (\dots\dots\dots, \dots\dots\dots, \dots\dots\dots)$

In every pair of these examples, we find the ratios of corresponding sides are equal and the pairs of corresponding angles are equal.

Consider another example.

In the adjacent figure if two triangles ABC and ADE are similar then we write it as $\triangle ABC \sim \triangle ADE$. If these two triangles are placed one over the other, you will find that the pairs of corresponding angles are equal.

- (i.e.) $\angle A \cong \angle A$
- $\angle B \cong \angle D$ (why?)
- $\angle C \cong \angle E$ (Why?)

and the ratio of corresponding sides are equal

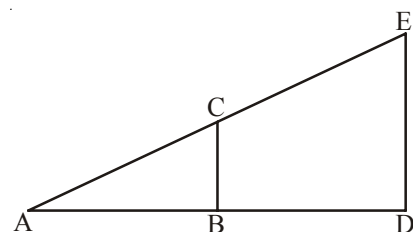

$$(i.e.) \quad \frac{AB}{AD} = \frac{BC}{DE} = \frac{AC}{AE}$$

Let us see an illustration, how the principle of similar triangles helps us to find out the heights of the objects located far away.

Illustration: A girl stretched her arm towards a pillar, holding a pencil vertically in her arm by standing at a certain distance from the pillar. She found that the pencil exactly covers the pillar as in figure. If we compare this illustration with the previous example, we can say that

$$\frac{\text{Height of the pillar}(H)}{\text{Length of the pencil}(h)} = \frac{\text{Distance of pillar from the girl}(D)}{\text{Length of her arm}(d)}$$

By measuring the length of the pencil, length of her arm and distance of the pillar, we can estimate the height of the pillar.

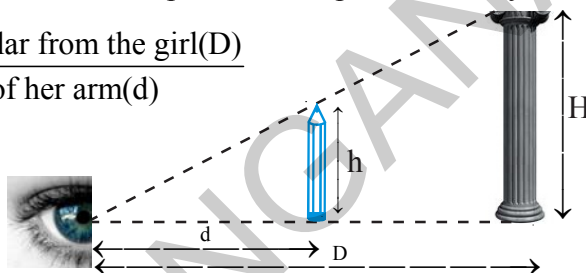

Try This

Stretch your hand, holding a scale in your hand vertically and try to cover your school building by the scale. Adjust your distance from the building. Draw the figure and estimate height of the school building.

Example 1: In the adjacent figure $\triangle ABC \sim \triangle PQR$, and $\angle C = 53^\circ$. Find the side PR and $\angle P$.

Solution: $\triangle ABC \sim \triangle PQR$

When two triangles are similar their corresponding angles are equal and corresponding sides are in proportion.

$$\frac{PR}{AC} = \frac{PQ}{AB} \Rightarrow \frac{PR}{5} = \frac{2}{4}$$

$$PR = \frac{2}{4} \times 5 = 2.5$$

$$\text{and } \angle R = \angle C = 53^\circ$$

Sum of all the three angles in a triangle is 180° .

$$i.e. \quad \angle P + \angle Q + \angle R = 180^\circ$$

$$\angle P + 90^\circ + 53^\circ = 180^\circ$$

$$\angle P = 180^\circ - 143^\circ = 37^\circ$$

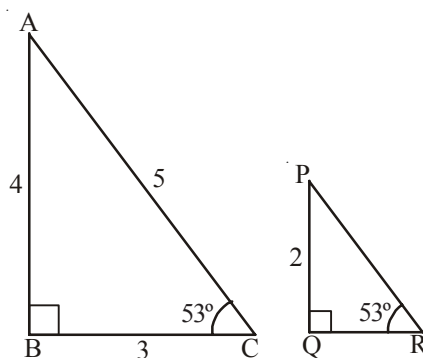

Example 2: Draw two squares of different sides. Can you say they are similar? Explain. Find the ratio of their perimeters and areas. What do you observe?

Solution: Let us draw two squares of sides 2 cm and 4 cm. As all the sides are in

$$\text{proportion } \frac{AB}{PQ} = \frac{BC}{QR} = \frac{CD}{RS} = \frac{DA}{SP} = \frac{2}{4} = \frac{1}{2}$$

And all the pairs of corresponding angles are 90°

So $\square ABCD \sim \square PQRS$

Perimeter of $\square ABCD = 4 \times 2 = 8$ cm

Perimeter of $\square PQRS = 4 \times 4 = 16$ cm

Ratio of their perimeters $= 8 : 16 = 1 : 2$

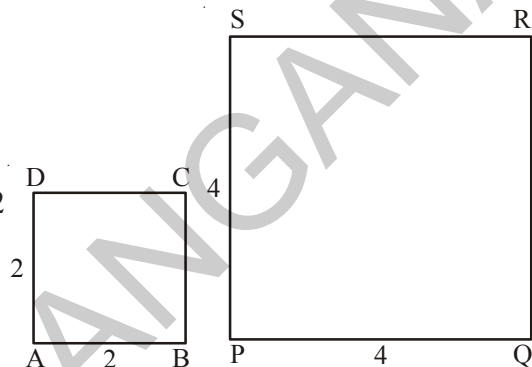

Ratio of their perimeters is same as ratio of their corresponding sides.

$$\text{Area of } \square ABCD = 2 \times 2 = 4 \text{ cm}^2$$

$$\text{Area of } \square PQRS = 4 \times 4 = 16 \text{ cm}^2$$

$$\therefore \text{Ratio of their areas} = 4 : 16 = 1 : 4 = 1^2 : 2^2$$

Ratio of the areas of squares = Ratio of squares of their corresponding sides.

Example 3: Jagadeesh tried to estimate the height of a tree by covering the height with a vertical scale holding it at a distance of 50 cm from his eyes along horizontal line as shown in the figure. If the scale measurement of the tree is 15 cm and distance of the tree from Jagadeesh is 50 m. Find the actual height of the tree.

Solution: From the figure $\triangle OAB \sim \triangle OCD$

Corresponding sides of two similar triangles are in proportion.

$$\therefore \frac{OA}{OC} = \frac{AB}{CD} = \frac{OB}{OD}$$

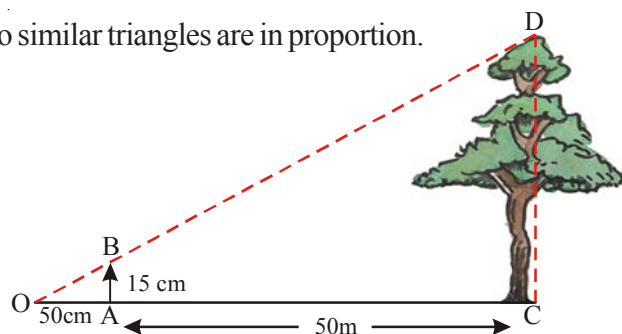

$$\therefore \frac{0.5}{50} = \frac{0.15}{CD} \Rightarrow CD = \frac{50 \times 0.15}{0.5} = 15 \text{ m}$$

\therefore Height of the tree = 15 m

8.2 Dilations

Some times we need to enlarge the figures say for example while making cutouts, and some times we reduce the figures during designing. Here in every case the figures must be similar to the original. This means we need to draw enlarged or reduced similar figures in daily life. This method of drawing enlarged or reduced similar figure is called 'Dilation'.

Observe the following dilation ABCD, it is a rectangle drawn on a graph sheet.

Every vertex A, B, C, D are joined from 'O' and produced to double the length upto A¹, B¹, C¹ and D¹ respectively. Then A¹, B¹, C¹, D¹ are joined in order to form a rectangle whose sides are twice the lengths of each side of \square ABCD.

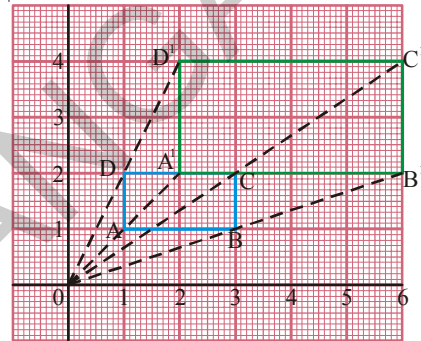

Here, O is called centre of dilation and $\frac{OA^1}{OA} = \frac{2}{1} = 2$, '2' is called scale factor.



Do This

1. Draw a triangle on a graph sheet and draw its dilation with scale factor 3. Are those two figures are similar?
2. Draw a square on a graph sheet and draw its dilations with scale factor 4 and 5.

8.2.1 Constructing a Dilation

Example 4: Construct a dilation with scale factor 2 of a triangle using only a ruler and compasses.

Solution:

Step 1: Draw a Δ PQR and choose the center of dilation C which is not on the triangle. Join every vertex of the triangle from C and produce.

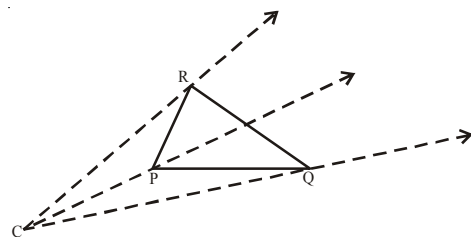

Step 2: By using compasses, mark three points P^1 , Q^1 and R^1 on the projections so that

$$CP^1 = k(CP) = 2 CP$$

$$CQ^1 = 2 CQ$$

$$CR^1 = 2 CR$$

Step 3: Join P^1Q^1 , Q^1R^1 and R^1P^1 . Notice that $\Delta P^1Q^1R^1 \sim \Delta PQR$

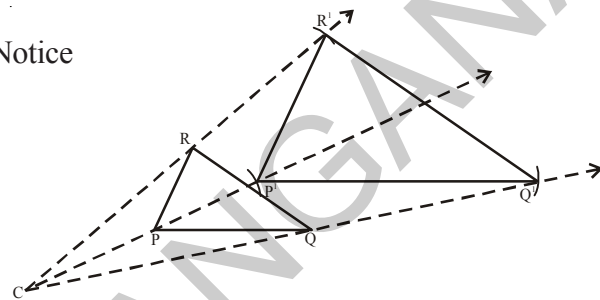
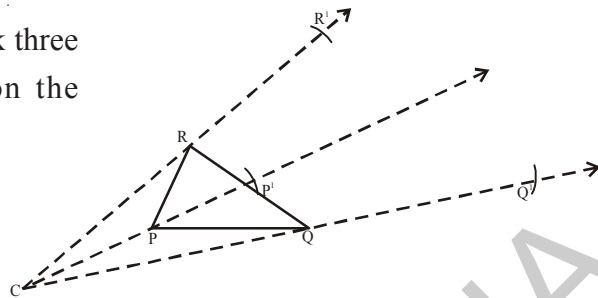

Exercise - 8.1

- Name any three pairs of congruent objects, you use daily.
- Draw two congruent figures. Are they similar? Explain
 - Take two similar shapes. If you slide, rotate or flip one of them, does the similarity remain?
- If $\Delta ABC \cong \Delta NMO$, then name pair of the congruent sides and angles.
- State whether the following statements are true. Explain with reasons.
 - Two squares of side 3 cm each and one of them rotated through 45° are congruent.
 - Any two right triangles with hypotenuse 5 cm, are congruent.
 - Any two circles of radii 4 cm each are congruent.
 - Two equilateral triangles of side 4 cm each but labeled as ΔABC and ΔLHN then, they are not congruent.
 - Mirror image of a polygon is congruent to the original.
- Draw a polygon on a square dot sheet. Also draw it's congruent figures in different directions and mirror image of it.
- Using a square dot sheet or a graph sheet draw a rectangle and construct a similar figure. Find the perimeter and areas of both and compare their ratios with the ratio of their corresponding sides.

7. 7 pillars are used to hold a slant iron gudder as shown in the figure. If the distance between adjoining two pillars is 1 m and height of the last pillar MN is 10.5m. Find the heights of rest of the pillars.

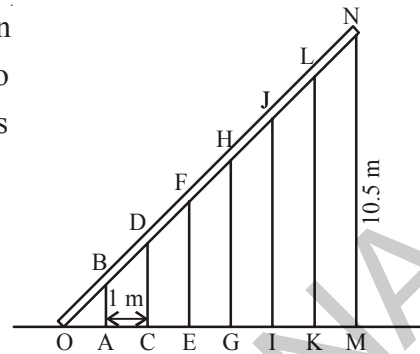

8. Standing at 5 m apart from a vertical pole of height 3 m, Sudha observed a building behind the pillar and found that tip of the pillar is in line with the top of the building. If the distance between pillar and building is 10m, estimate the height of the building. [Here height of Sudha is neglected]
9. Draw a quadrilateral of any measurements. Construct a dilation of scale factor 3. Measure their corresponding sides and verify whether they are similar.

8.3 Symmetry

Look at the following figures. If we fold them exactly to their halves, one half of each figure exactly coincides with other half.



What do we call such figures? What do we call the line along which we fold the figures so that one half coincides with the other? Do you recollect from earlier classes?

They are called symmetric figures and the line which cuts them exactly into two halves is called line of symmetry.



Do These

Draw all possible lines of symmetry for the following figures.

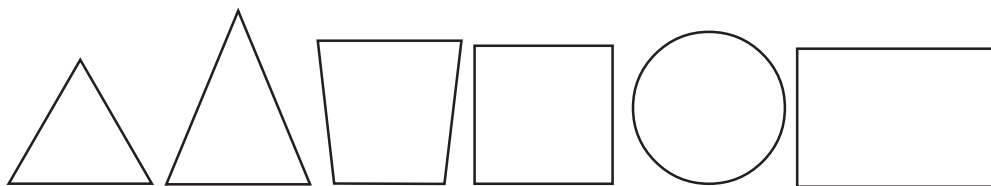

Observe the following symmetric designs which we see around us.



All these designs are products of different kinds of symmetry.

Here, the dog has her face made perfectly symmetrical with a bit of photo magic. Do you observe a vertical line at the center?

It is called 'line of symmetry' or 'mirror line'.

We call this symmetry as 'Reflection symmetry' or 'Mirror symmetry'.



Consider another example, reflection of a hill in a lake. It is also reflection symmetry and line of symmetry is a horizontal line that separates the hill and its image. This may not be perfectly symmetric because lower part is blurred by the lake surface.



8.3.1 Rotational symmetry

Observe the lines of symmetry in the following.

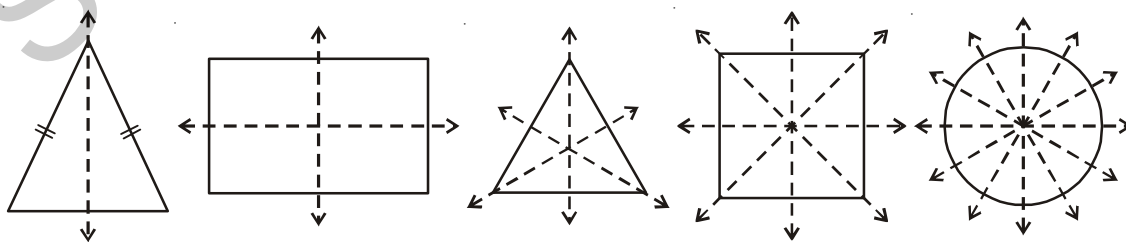

Different geometrical figures have different number of lines of symmetry.

Rotate each figure given above, about its centre and find out how many times it resembles its initial position during its one complete rotation.

For example, rectangle has two lines or axes of symmetry. When a rectangle is rotated about its center its shape resembles the initial position two times. We call this number as ‘order of rotation’.

Tabulate your findings in the following table.

Geometrical figure	No. of axes of symmetry	No. of times it resumes its initial position	Order of rotation
Isosceles triangle
Rectangle	2	2	2
Equilateral triangle
Square
Circle



Think, Discuss and Write

1. What is the relation between order of rotation and number of lines of symmetry of a geometrical figure?
2. How many lines of symmetry does a regular polygon have? Is there any relation between number of sides and order of rotation of a regular polygon?

8.3.2 Point symmetry

Observe the adjacent figure. Does it have line of symmetry? It does not have line symmetry, but it has another type of symmetry. The figure looks the same either you see it from upside or from down side. i.e., from any two opposite directions. This is called point symmetry. If you look at the figure you may observe that every part of it has a matching point. If you draw a line through its centre, it cuts the diagram on either sides of the center at equal distance. Draw some more lines through center and verify. Now this figure is said to have ‘point symmetry’.



We also observe that some letters of English alphabet too have point symmetry .





Try These

1. Identify which of the following have point symmetry.

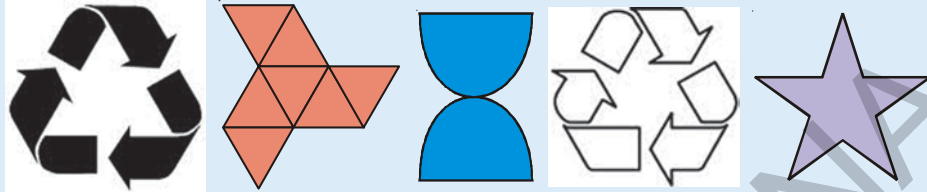

2. Which of the above figures have line of symmetry?
3. What can you say about the relation between line symmetry and point symmetry?

8.3.3 Applications of symmetry

- Majority of the objects what we use have atleast one type of symmetry.
- Most of the Machine made products are symmetric. This speeds up the production.

Observe these patterns

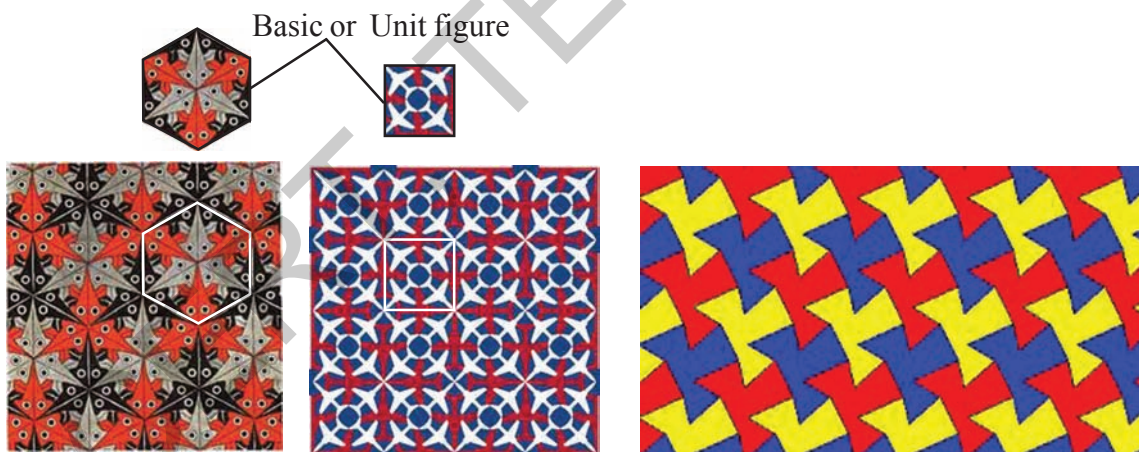

Where do you find these? We find these patterns in floor designs and fabric painting etc.

How these patterns are formed?

Usually these patterns are formed by arranging congruent figures or mirror images side by side in all the directions to spread upon the area without any overlaps or gaps. This is called tessellation. This enhances the beauty of the diagrams.

Are they symmetric as a whole?

Does the basic figure which is used to form the tessellation is symmetric?

You can observe that only some patterns have symmetry as a whole as in fig(b) and others does n't have any symmetry as a whole as in fig(a), though the basic figures/unit figures are symmetric. Observe the following tessellations again. What are the basic shapes used in these tessellations?

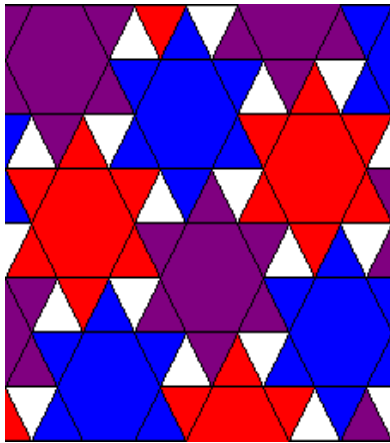

Fig. (a)

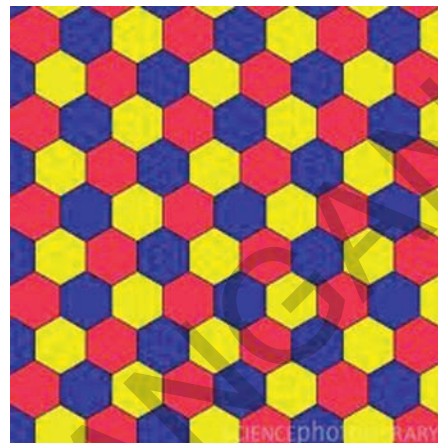

Fig. (b)

You may notice that the basic shapes used to draw tessellation are pentagon, rectangle, squares and equilateral triangle. Most tessellations can be formed with these shapes.



Exercise - 8.2

1. Cut the bold type English alphabets (capital) and paste in your note book. Draw possible number of lines of symmetry for each of the letter.
 - (i) How many letters have no line of symmetry?
 - (ii) How many letters have one line of symmetry?
 - (iii) How many letters have two lines of symmetry?
 - (iv) How many letters have more than two lines of symmetry?
 - (v) Which of them have rotational symmetry?
 - (vi) Which of them have point symmetry?
2. Draw lines of symmetry for the following figures. Identify which of them have point symmetry. Is there any relation between line symmetry and point symmetry?

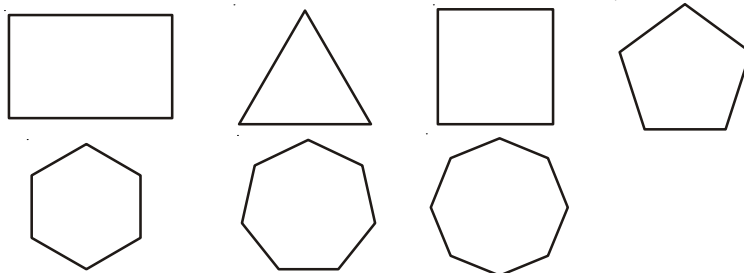

3. Name some natural objects whose faces have atleast one line of symmetry.
4. Draw three tessellations and name the basic shapes used in your tessellation.



What we have discussed

- Figures are said to be congruent if they have same shape and size.
- Figures are said to be similar if they have same shapes but with different size.
- If we flip, slide or rotate the congruent/similar shapes their congruence/similarity remains the same.
- Some figures may have more than one line of symmetry.
- Symmetry is of three types namely line symmetry, rotational symmetry and point symmetry.
- With rotational symmetry, if the figure is rotated around a central point, it appears the same as original two or more times. The number of times it appears as the same, is called it's order of symmetry.
- The method of drawing enlarged or reduced similar figures is called Dilation.
- The patterns formed by repeating figures to fill a plane without gaps or overlaps are called tessellations.





9.0 Introduction

Devarsh wants to purchase a plot to construct a house for himself. Some of the shapes of the plots visited by him are shown below.

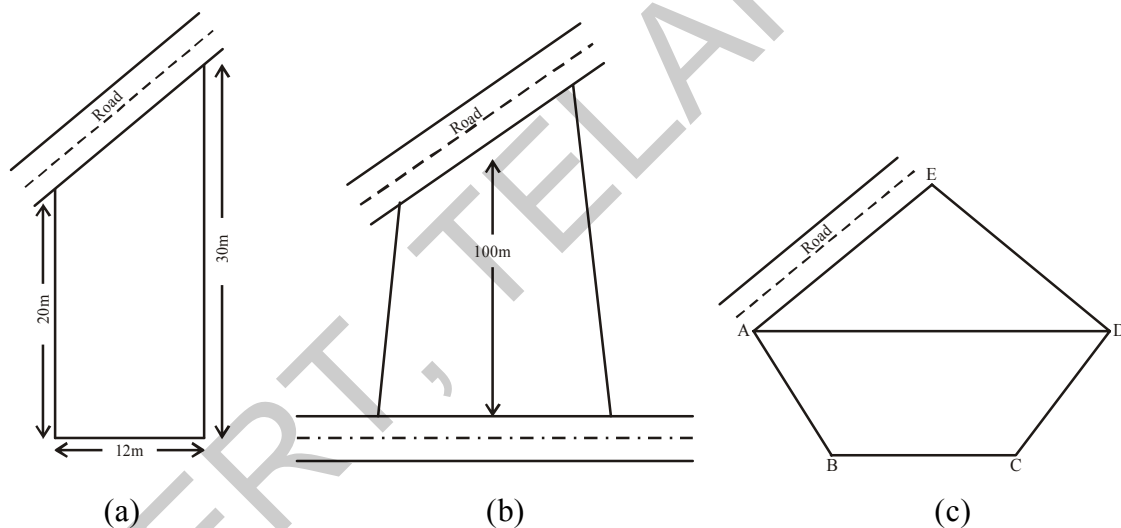

Plot (a) is in the shape of a trapezium, Plot (b) is in the shape of a quadrilateral and plot (c) is in the shape of a pentagon. He wants to calculate the area of such figures to construct his house in the field.

We have learnt how to find the area of a rectangle, square, parallelogram, triangle and rhombus. In this chapter we will learn how to find the area of a trapezium, quadrilateral, circle and a sector. First let us review what we have learnt about the area of a rectangle, square, parallelogram and rhombus.



Do This

1. Find the area of the following figures.

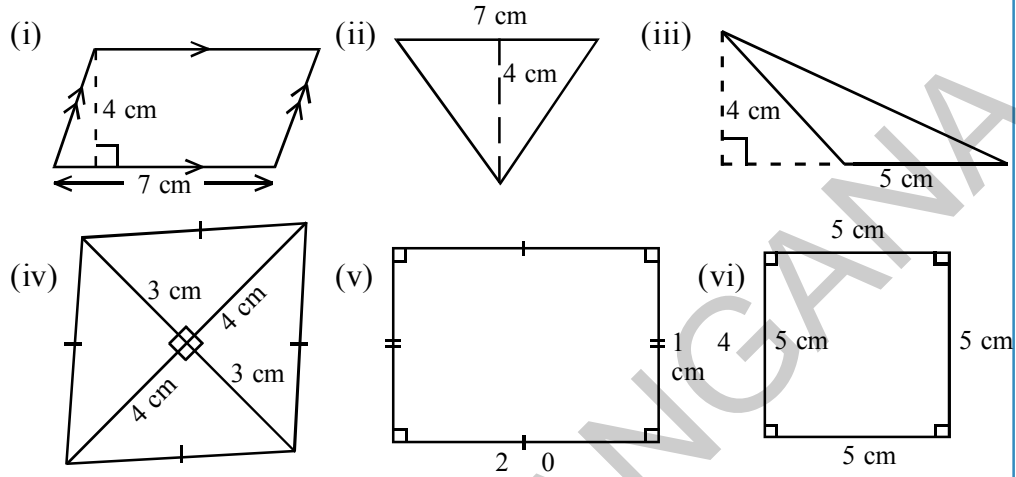

2. The measurements of some plane figures are given in the table below. However, they are incomplete. Find the missing information

Figure	Measurements	Formula for area	Area of the given figure
	Side of the square is 15 cm	$A = \text{side} \times \text{side}$
	Length = 20 cm Breadth =	$A = l \times b$	280cm^2
	Base = 5 cm Height =	$A = \dots\dots\dots$	60cm^2
	Height = 7.6cm Base =	$A = b \times h$	38cm^2
	$d_1 = 4\text{ cm}$ $d_2 = 3\text{ cm}$

9.1 Area of a Trapezium

Kumar owns a plot near the main road as in the figure below. Unlike some other rectangular plots in his neighbourhood, the plot has only a pair of parallel sides. So, it is nearly a trapezium in shape. Can you find out its area?

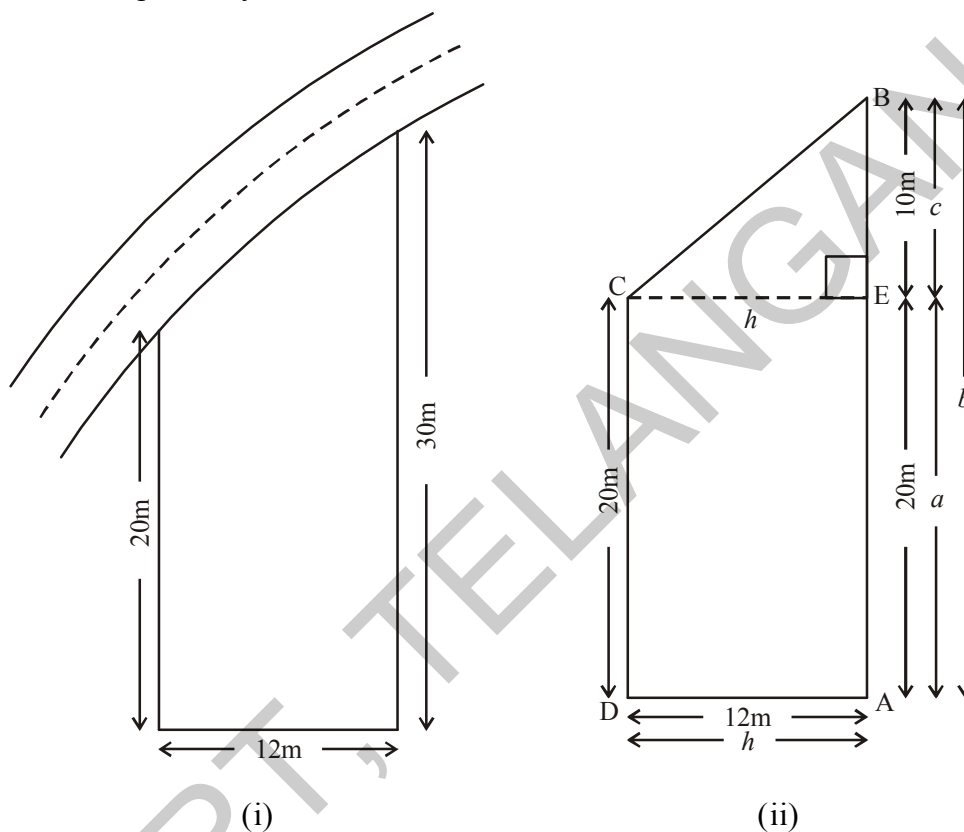

Let us name the vertices of this plot as shown in figure (i). By drawing $CE \perp AB$, we can divide it into two parts, one of rectangular shape and the other of triangular shape (which is right angled), as shown in figure (ii).

$$\text{Area of } \triangle ECB = \frac{1}{2} \times h \times c = \frac{1}{2} \times 12 \times 10 = 60 \text{ m}^2$$

$$\text{Area of rectangle ADCE} = AE \times AD = 20 \times 12 = 240 \text{ m}^2$$

$$\begin{aligned} \text{Area of trapezium ABCD} &= \text{Area of } \triangle ECB + \text{Area of rectangle ADCE} \\ &= 60 + 240 = 300 \text{ m}^2 \end{aligned}$$

Thus we can find the area of the trapezium ABCD by combining the two areas i.e. rectangle ADCE and triangle ECB.

$$\therefore \text{Area of ABCD} = \text{Area of ADCE} + \text{Area of } \triangle ECB$$

$$= (h \times a) + \frac{1}{2}(h \times c)$$

$$= h\left(a + \frac{1}{2}c\right)$$

$$= h\left(\frac{2a+c}{2}\right)$$

$$= h\left(\frac{2a+c}{2}\right) = \frac{h}{2}(a+a+c)$$

$$= \frac{1}{2}h(a+b) \quad (\because c+a=b)$$

$$= \frac{1}{2} \times (\text{perpendicular distance between two parallel sides}) \times (\text{sum of lengths of parallel sides})$$

$$\overline{AD} = \overline{EC} = h$$

$$\overline{AE} = a, \overline{AB} = b = a + c$$

By substituting the values of h, b and a in the above expression

$$\text{Area of trapezium ABCD} = \frac{1}{2}h(a+b)$$

$$= \frac{1}{2} \times 12 \times (30+20) = 300 \text{ m}^2$$

$$\text{Here } h = 12$$

$$a = 20$$

$$b = 30$$

Example 1: Here is a figure of a playground. Find the area of the playground.

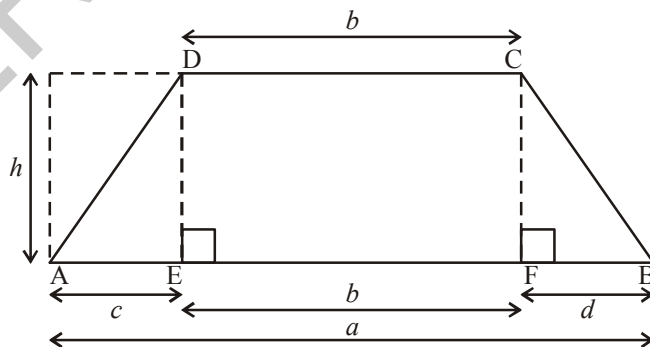

Solution: Here we can not divide the figure into one rectangle and one triangle. Instead, we may divide it into a rectangle and two triangles conveniently. Draw $DE \perp AB$ and $CF \perp AB$. So that trapezium ABCD is divided into three parts. One is rectangle DEFC and the other two are triangles; $\triangle ADE$ and $\triangle CFB$.

Area of trapezium ABCD = Area of triangle ADE + Area of Rectangle DEFC + Area of triangle CFB

$$\begin{aligned}
 &= \left(\frac{1}{2} \times h \times c\right) + (b \times h) + \left(\frac{1}{2} \times h \times d\right) \\
 &= h \left[\frac{1}{2}c + b + \frac{1}{2}d \right] \\
 &= h \left[\frac{c + 2b + d}{2} \right] \\
 &= h \left[\frac{c + b + d + b}{2} \right] \\
 &= h \left[\frac{a + b}{2} \right] \quad (\because c + b + d = a)
 \end{aligned}$$

So, we can write the formula for the area of a trapezium

$$\begin{aligned}
 &= \text{height} \times \left[\frac{\text{sum of parallel sides}}{2} \right] \\
 &= \frac{1}{2} \times \text{perpendicular distance between two parallel sides} \times (\text{sum of parallel sides})
 \end{aligned}$$



Activity

1. Draw a trapezium WXYZ on a piece of graph paper as shown in the figure and cut it out as shown in Fig. (i)

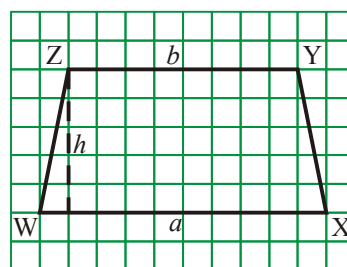

Fig. (i)

2. Find the Mid point of XY by folding its side XY and name it 'A' as shown in Fig.(ii)

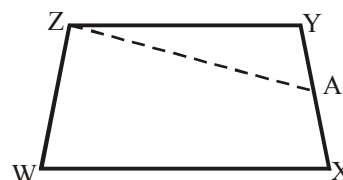
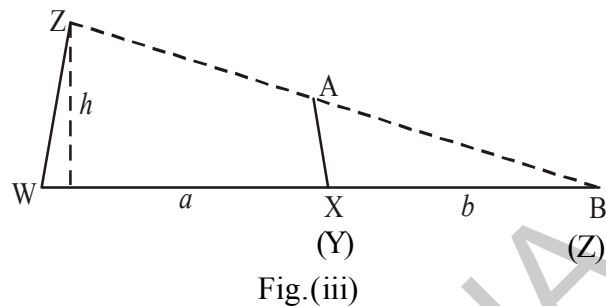

Fig. (ii)

3. Draw line segment AZ.

4. Cut trapezium WXAZ into two pieces by cutting along ZA. Place $\triangle ZYA$ as shown in the fig. (iii) where AY placed on AX in such a way that 'Y' coincides with 'X'. We get $\triangle WZB$.



What is the length of the base of the larger triangle? Write an expression for the area of this triangle fig. (iii)

5. The area of this triangle WZB and the area of the trapezium WXAZ are the same (How?)

Area of trapezium WXAZ = Area of triangle WZB

$$= \frac{1}{2} \times \text{height} \times \text{base} = \frac{1}{2} \times h \times (a + b)$$

Note: Check the area by counting the unit squares of graph.



Do This

1. Find the area of the following trapezium.

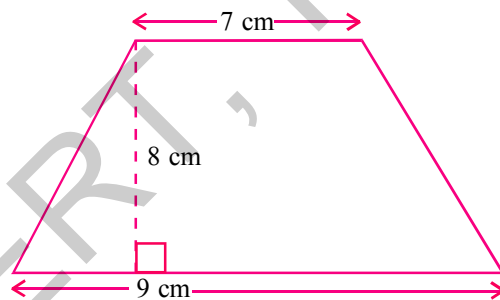

Fig. (i)

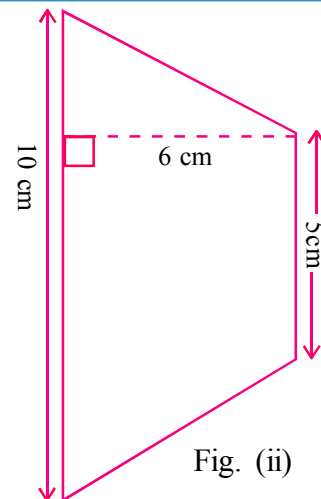
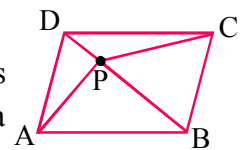

Fig. (ii)

2. Area of a trapezium is 16cm^2 . Length of one parallel side is 5 cm and distance between two parallel sides is 4 cm. Find the length of the other parallel side. Try to draw this trapezium on a graph paper and check the area.
3. ABCD is a parallelogram whose area is 100 sq. cm. P is any point inside the parallelogram (see fig.) find the area of $\text{ar}\triangle APB + \text{ar}\triangle CPD$.



Solved examples

Example 2: The parallel sides of trapezium are 9cm and 7cm long and the distance between them is 6cm. Find the area of the trapezium.

Solution: The sum of the lengths of parallel sides = $9 + 7 = 16\text{cm}$
Perpendicular Distance between them = 6cm

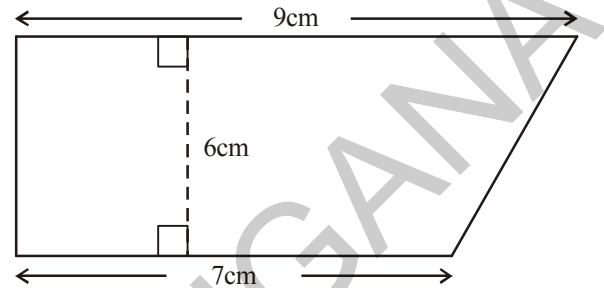

Area of the trapezium = $\frac{1}{2}$ (sum of the lengths of parallel sides) \times (distance between them)

$$= \left(\frac{1}{2} \times 16 \times 6\right) \text{cm}^2$$

$$= 48\text{cm}^2$$

Example 3: Area of a trapezium is 480cm^2 . Length of one of the parallel sides is 24cm and the distance between the parallel sides is 8cm. Find the length of the other parallel side.

Solution : One of the parallel sides = 24cm

Let the length of the other parallel sides be 'x' cm

Also, area of the trapezium = 480cm^2

Distance between the parallel sides = 8 cm

$$\therefore \text{Area of a trapezium} = \frac{1}{2} \times (a + b) \times h$$

$$\therefore 480 = \frac{1}{2} \times (24 + x) \times 8$$

$$\Rightarrow 480 = 96 + 4x$$

$$\Rightarrow 480 - 96 = 4x$$

$$\Rightarrow 4x = 384$$

$$\Rightarrow x = \frac{384}{4} = 96$$

\therefore The length of the other parallel side = 96 cm

Example 4: The ratio of the lengths of the parallel sides of a trapezium is 4:1. The distance between them is 10cm. If the area of the trapezium is 500 cm^2 . Find the lengths of the parallel sides.

Solution: Area of the trapezium = 500 cm^2

Distance between the parallel sides of the trapezium = 10 cm

Ratio of the lengths of the parallel sides of the trapezium = 4 : 1

Let the lengths of the parallel sides of the trapezium be $4x$ and x .

$$\text{Area of the trapezium} = \frac{1}{2}(a + b) \times h$$

$$\Rightarrow 500 = \frac{1}{2}(x + 4x) \times 10$$

$$\Rightarrow 500 = (x + 4x) 5$$

$$\Rightarrow 500 = 25x$$

$$\Rightarrow x = \frac{500}{25} = 20$$

\therefore One parallel side = 20cm

\therefore The other parallel side = $4x = 4 \times 20 = 80 \text{ cm}$ (\because parallel sides are in 4:1)

Example 5: In the given figure, ABED is a parallelogram in which $AB = DE = 10 \text{ cm}$ and the area of $\triangle BEC$ is 72 cm^2 . If $CE = 16 \text{ cm}$, find the area of the trapezium ABCD.

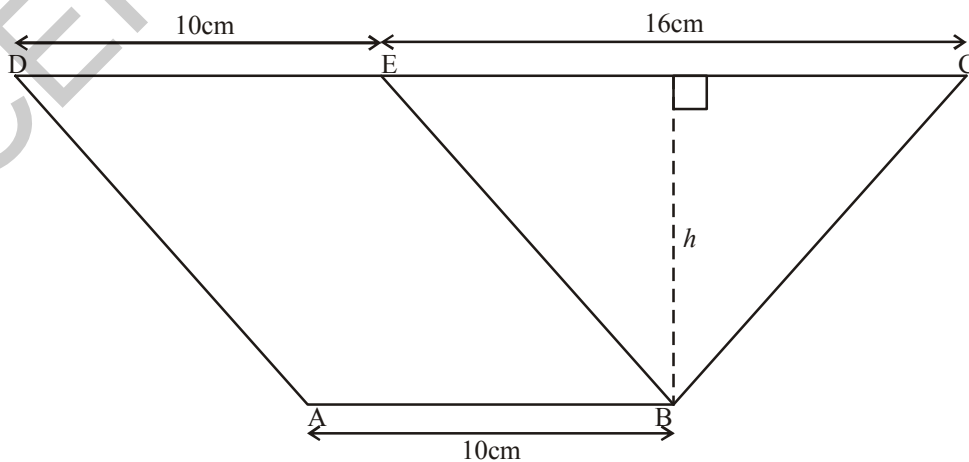

Solution: Area of $\triangle BEC = \frac{1}{2} \times \text{Base} \times \text{altitude}$

$$72 = \frac{1}{2} \times 16 \times h$$

$$h = \frac{72 \times 2}{16} = 9 \text{ cm}$$

In trapezium ABCD

$$AB = 10 \text{ cm}$$

$$DC = DE + EC (\because DE = AB)$$

$$= 10 + 16 = 26 \text{ cm}$$

\therefore Area of the trapezium ABCD

$$= \frac{1}{2} \times (a + b) \times h$$

$$= \frac{1}{2} (AB + DC) h$$

$$= \frac{1}{2} (10 + 26) \times 9$$

$$= 18 \times 9$$

$$= 162 \text{ cm}^2$$

Example 6: Mohan wants to buy a field on a river-side. A plot of field as shown in the adjacent figure is available for sale. The length of the river side is double the length of the road side and are parallel.

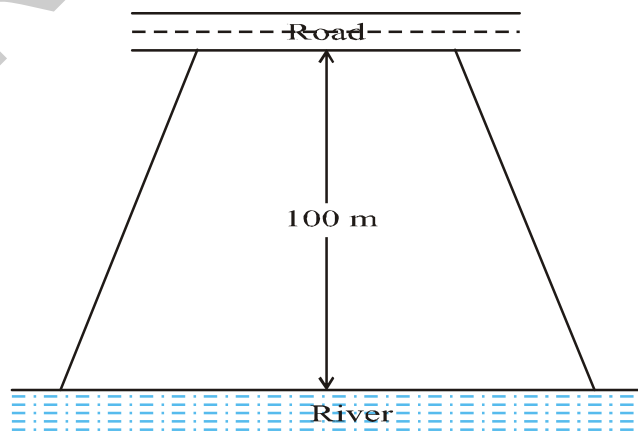

The area of this field is $10,500\text{m}^2$ and the distance between the river and road is 100 m. Find the length of the side of the plot along the river.

Solution: Let the length of the side of the field along the road be x m.

Then, length of its side along the river = $2x$ m.

Distance between them = 100 m.

$$\text{Area of the field} = \frac{1}{2}(a + b) \times h$$

$$\Rightarrow 10,500 = \frac{1}{2}(x + 2x) \times 100$$

$$\Rightarrow 10,500 = 3x \times 50$$

$$\Rightarrow x = \frac{10,500}{3 \times 50} = 70$$

$$\begin{aligned} \therefore \text{Length of the plot on river side} &= 2x = 2 \times 70 \\ &= 140 \text{ m} \end{aligned}$$

9.2 Area of a Quadrilateral

A quadrilateral can be split into two triangles by drawing one of its diagonals. This 'Triangulation' helps us to find the area of a quadrilateral.

Mahesh split the quadrilateral ABCD into two triangles by drawing the diagonal AC.

We know that the area of a triangle can be found using two measurements, base of the triangle and vertical height of the triangle

Mahesh has drawn two perpendicular lines to AC from B and D; named their lengths as h_1 and h_2 respectively.

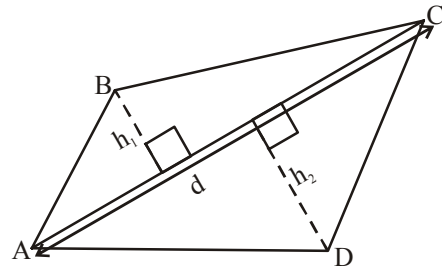

$$\text{Area of the quadrilateral ABCD} = (\text{area of } \triangle ABC) + (\text{area of } \triangle ADC)$$

$$= \left(\frac{1}{2} \times AC \times h_1 \right) + \left(\frac{1}{2} AC \times h_2 \right)$$

$$= \frac{1}{2} AC(h_1 + h_2)$$

$$\text{Area of quadrilateral ABCD} = \frac{1}{2} d(h_1 + h_2)$$

Where 'd' denotes the length of the diagonal AC.



Try These

We know that parallelogram is also a quadrilateral. Let us split such a quadrilateral into two triangles. Find their areas and subsequently that of the parallelogram. Does this process in tune with the formula that you already know?

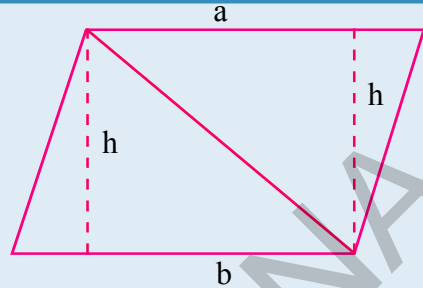

Area of a quadrilateral = $\frac{1}{2} \times \text{Length of a diagonal} \times \text{Sum of the lengths of the perpendiculars drawn from the remaining two vertices on the diagonal.}$

Example 7: Find the area of quadrilateral ABCD

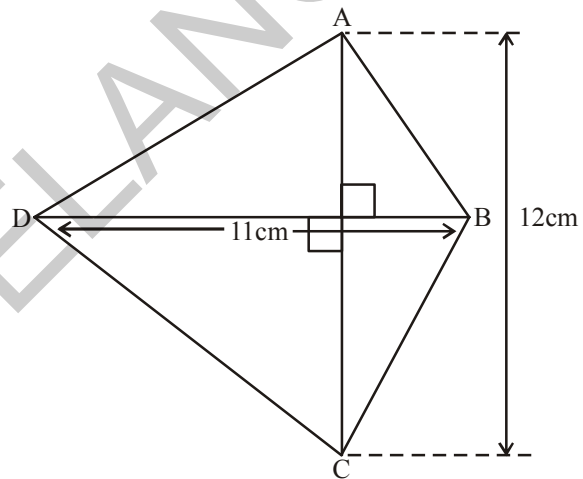

Fig. (i)

Solution: Area of quadrilateral

$$ABCD = \frac{1}{2} d(h_1 + h_2)$$

Sum of the lengths of perpendiculars from the remaining two vertices on the diagonal AC = $(h_1 + h_2)$

$$h_1 + h_2 = 12 \text{ cm.}$$

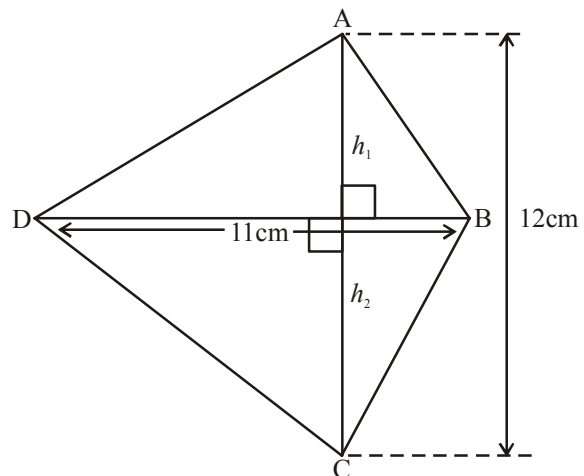

Fig. (ii)

Length of the diagonal (BD) = 11 cm.

$$\therefore \text{Area of quadrilateral} = \frac{1}{2} d(h_1 + h_2) = \frac{1}{2} \times 12 \times 11 = 6 \times 11 = 66 \text{ cm}^2.$$

9.3 Area of Rhombus

We use triangulation method of splitting into triangles to find a formula for the area of rhombus.

In the figure ABCD is a rhombus. We know that the diagonals of a rhombus are perpendicular bisectors of each other.

$$\therefore OA = OC, \quad OB = OD$$

$$\text{And } \angle BOA = \angle COB = \angle DOC = \angle AOD = 90^\circ$$

Area of rhombus ABCD = area of ΔABC + area of ΔADC

$$\begin{aligned} &= \frac{1}{2} \times AC \times OB + \frac{1}{2} \times AC \times OD \\ &= \frac{1}{2} \times AC (OB + OD) \\ &= \frac{1}{2} \times AC \times BD \quad (\because OB + OD = BD) \end{aligned}$$

Thus area of a rhombus = $\frac{1}{2} \times d_1 d_2$, where d_1, d_2 are its diagonals.

In other words we say, area of a rhombus is half the product of its diagonals.

Example 8: Find the area of a rhombus whose diagonals are of length 10 cm and 8.2 cm.

Solution:

$$\begin{aligned} \text{Area of the rhombus} &= \frac{1}{2} \times d_1 d_2 \text{ (where } d_1, d_2 \text{ are lengths of diagonals)} \\ &= \frac{1}{2} \times 10 \times 8.2 \\ &= 41 \text{ cm}^2 \end{aligned}$$

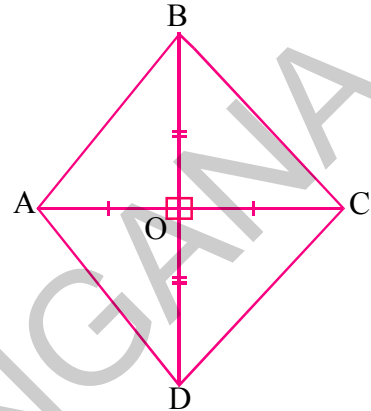

9.4 Surveying the field

A surveyor has noted the measurements of a field in his field book in metres as shown below. Find the area of that field.

	To S	
	200	
25 to T ←	160	
	110	→ 60 to R
25 to L ←	70	
	30	→ 40 to Q
	From P	

The above data gives the following information

1. The field is in the shape of a hexagon whose vertices are P, Q, R, S, T and L.
2. PS is taken as diagonal
3. Vertices Q and R on one side of the diagonal and the vertices T and L are on another side.
4. The perpendicular drawn from Q to A is 40 m. Similarly other perpendiculars drawn from R, T, and L.
5. In the field book the measurements are real and recorded from bottom to top.
6. The field is divided into 2 triangles, 2 trapeziums.

We can find the following measurements from the above figure

$$AC = PC - PA$$

$$= 110 - 30 = 80 \text{ m}$$

$$CS = PS - PC$$

$$= 200 - 110 = 90 \text{ m}$$

$$DS = PS - PD$$

$$= 200 - 160 = 40 \text{ m}$$

$$BD = PD - PB$$

$$= 160 - 70 = 90 \text{ m}$$

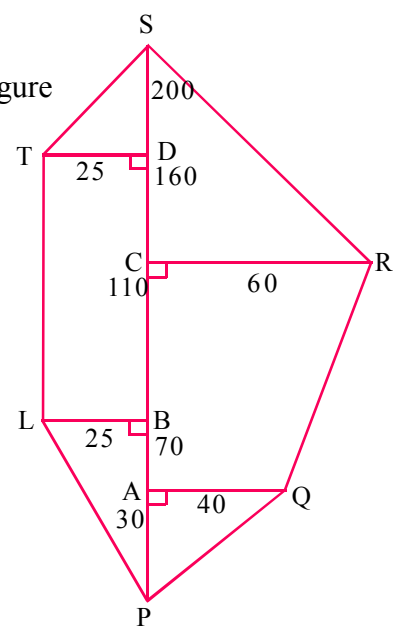

$$\begin{aligned} \text{Area of } \triangle APQ &= \frac{1}{2} \times b \times h \\ &= \frac{1}{2} \times 30 \times 40 = 600 \text{ Sq.m.} \end{aligned}$$

$$\begin{aligned} \text{Area of trapezium AQRC} &= \frac{1}{2} \times h(a + b) \\ &= \frac{1}{2} \times AC (AQ + CR) \\ &= \frac{1}{2} \times 80 \times (40 + 60) \\ &= \frac{1}{2} \times 80 \times 100 \\ &= 4000 \text{ Sq. m.} \end{aligned}$$

$$\text{Area of } \triangle CRS = \frac{1}{2} \times CR \times CS = \frac{1}{2} \times 60 \times 90 = 2700 \text{ Sq.m.}$$

$$\begin{aligned} \text{Area of trapezium PLTS} &= \frac{1}{2} \times h(a + b) \\ &= \frac{1}{2} \times LB (TL + SP) \\ &= \frac{1}{2} \times 25(90 + 200) \quad (\because TL = BD = 90) \\ &= \frac{1}{2} \times 25 \times 290 \\ &= 3625 \text{ Sq.m.} \end{aligned}$$

$$\begin{aligned} \text{Area of the field} &= 600 + 4000 + 2700 + 3625 \\ &= 10,925 \text{ Sq. m.} \end{aligned}$$



Do This

The following details are noted in metres in the field book of a surveyor. Find the area of the fields.

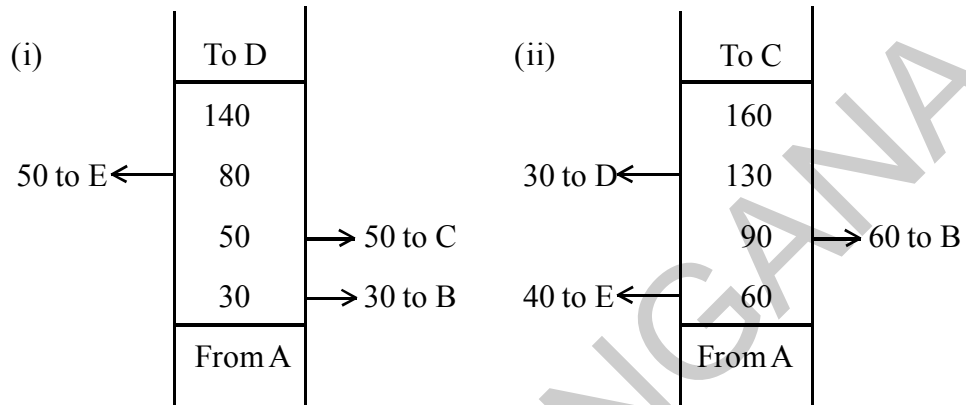

Think and Discuss

A parallelogram is divided into two congruent triangles by drawing a diagonal across it. Can we divide a trapezium into two congruent triangles?



Try These

Find the area of following quadrilaterals.

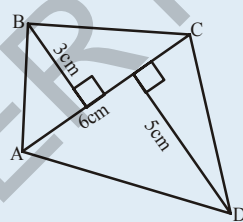

(i)

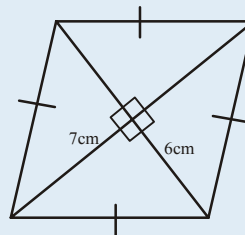

(ii)

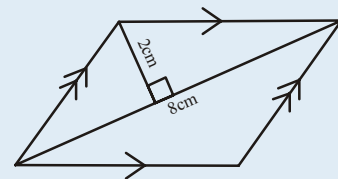

(iii)

9.5 Area of a Polygon

The area of a polygon may be obtained by dividing the polygon into a number of simple shapes (triangles, rectangles etc.) Then the areas of each of them can be calculated and added up to get the required area.

Observe the following pentagon in the given figure:

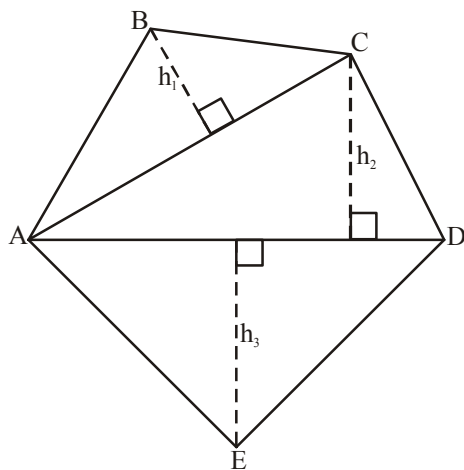

Fig. (i)

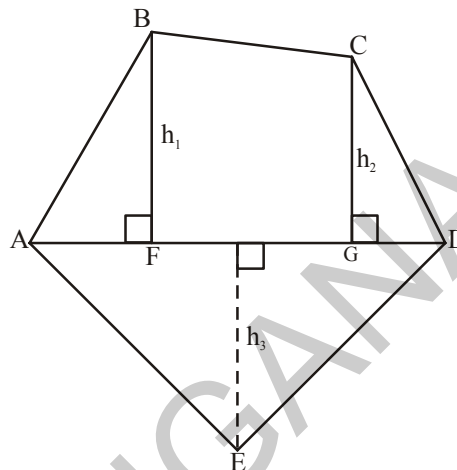

Fig. (ii)

Fig.(i) : By drawing two diagonals AC and AD the pentagon ABCDE is divided into three parts. So, area ABCDE = area of ΔABC + area of ΔACD + area of ΔAED

Fig.(ii) : By drawing one diagonal AD and two perpendiculars BF and CG on it, pentagon ABCDE is divided into four parts. So, area of ABCDE = area of right angled ΔFBA + area of trapezium BFGC + area of right angled ΔCGD + area of ΔAED .

Why is this so? (Identify the parallel sides of trapezium BFGC).



Try These

- (i) Divide the following polygon into parts (triangles and trapezium) to find out its area.

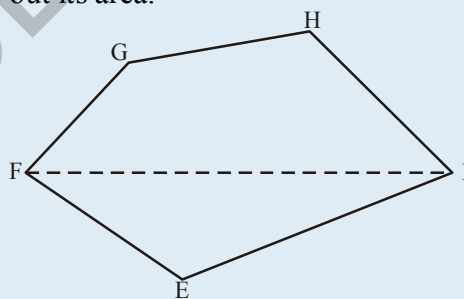

FI is a diagonal of polygon EFGHI

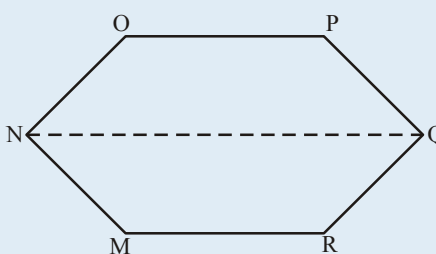

NQ is a diagonal of polygon MNOPQR

- (ii) Polygon ABCDE is divided into parts as shown in the figure. Find the area if AD = 8cm, AH = 6 cm, AF = 3cm and perpendicular BF = 2cm, CH = 3cm and EG = 2.5cm

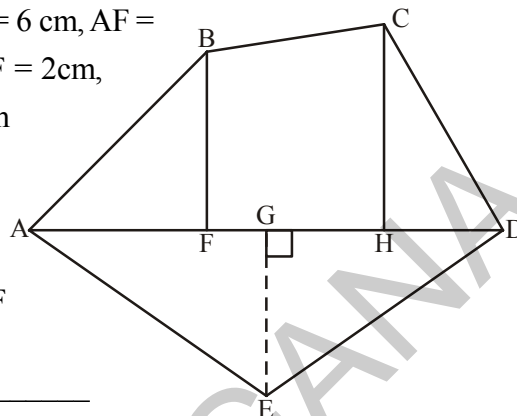

Area of polygon ABCDE = area of $\triangle AFB$ + _____

$$\begin{aligned} \text{Area of } \triangle AFB &= \frac{1}{2} \times AF \times BF \\ &= \frac{1}{2} \times 3 \times 2 = \end{aligned}$$

$$\begin{aligned} \text{Area of trapezium FBCH} &= FH \times \frac{(BF + CH)}{2} \\ &= 3 \times \frac{(2 + 3)}{2} \quad [\because FH = AH - AF] \end{aligned}$$

$$\text{Area of } \triangle CHD = \frac{1}{2} \times HD \times CH = \text{_____}$$

$$\text{Area of } \triangle ADE = \frac{1}{2} \times AD \times GE = \text{_____}$$

So, the area of polygon ABCDE =

- (iii) Find the area of polygon MNPQR if MP = 9 cm, MD = 7 cm, MC = 6 cm, MB = 4 cm, MA = 2 cm

NA, OD, QC and RB are perpendiculars to diagonal MP

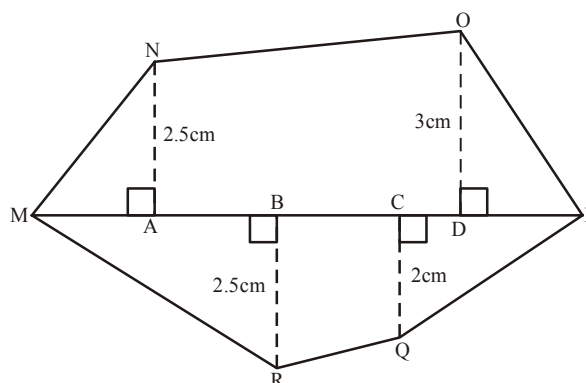

Example 9: Find the area of the field shown, along side all dimension are in metres.

Solution: Area of ABCDE = Area of ΔABH + area of trap BCFH + area of ΔCDF + Area of ΔAED

Now, area of ΔABH

$$= \frac{1}{2} \times AH \times HB$$

$$= \frac{1}{2} \times 25 \times 25$$

$$= \frac{625}{2} = 312.5 \text{ m}^2$$

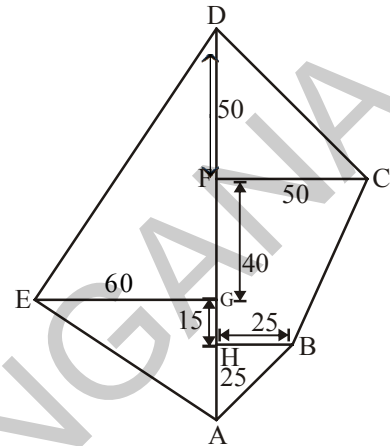

$$\text{Area of trap BCFH} = \frac{1}{2} \times (HB + FC) \times HF$$

$$= \frac{1}{2} (25 + 50) \times 55$$

$$= \frac{75 \times 55}{2} = 2062.5 \text{ m}^2$$

$$\text{Area of } \Delta CDF = \frac{1}{2} \times FC \times DF$$

$$= \frac{1}{2} \times 50 \times 50 = 1250 \text{ m}^2$$

$$\text{Area of } \Delta AED = \frac{1}{2} \times AD \times EG$$

$$= \frac{1}{2} \times 130 \times 60$$

$$= 3900 \text{ m}^2$$

Thus, area of ABCDE = 312.5 + 2062.5 + 1250 + 3900

$$= 7525 \text{ m}^2$$

Example 10: There is a hexagon MNOPQR of each side 5 cm and symmetric about NQ. Suresh and Rushika divided it into different ways. Find the area of this hexagon using both ways.

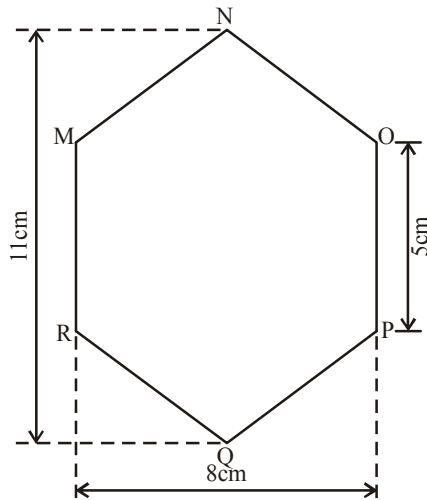
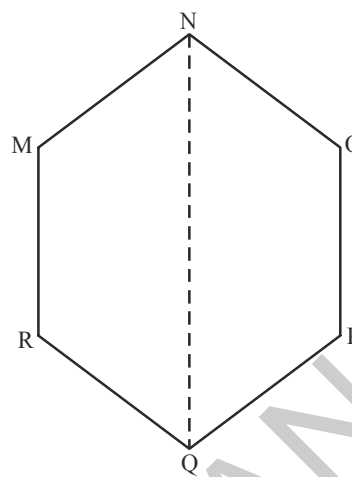
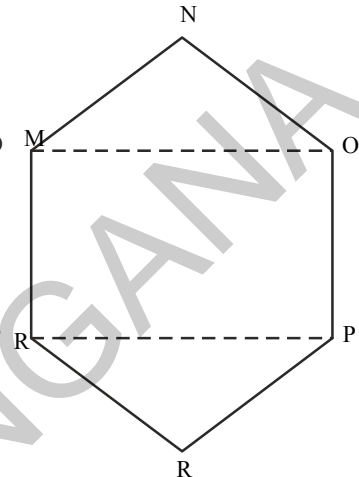

Fig. (i)



Suresh's Method



Rushika's Method

Fig. (ii)

Solution: **Method adopted by Suresh**

Since it is a regular hexagon. So, NQ divides the hexagon into two congruent trapeziums. You can verify it by paper folding.

Now area of trapezium MNQR

$$= 4 \times \frac{11+5}{2}$$

$$= 2 \times 16 = 32 \text{ cm}^2$$

$$\text{So the area of hexagon MNOPQR} = 2 \times 32 = 64 \text{ cm}^2$$

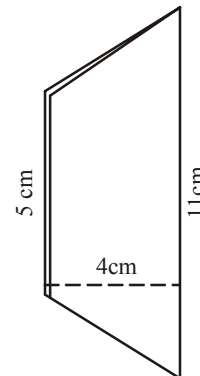

Method adopted by Rushika

ΔMNO and ΔRPQ are congruent triangles with altitude 3 cm (fig.4). You can verify this by cutting off these two triangles and placing them on one another.

$$\text{Area of } \Delta MNO = \frac{1}{2} \times 8 \times 3 = 12 \text{ cm}^2$$

$$= \text{Area of } \Delta RPQ$$

$$\text{Area of rectangle MOPR} = 8 \times 5 = 40 \text{ cm}^2$$

$$\text{Now, area of hexagon MNOPQR} = 40 + 12 + 12 = 64 \text{ cm}^2.$$

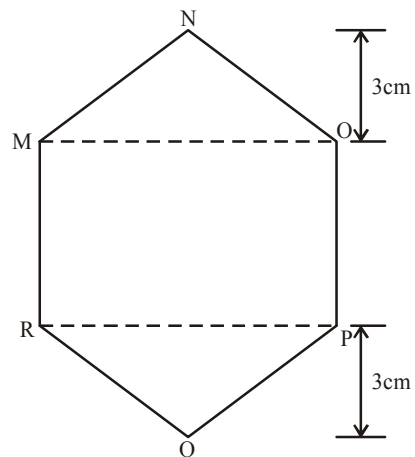



Exercise - 9.1

1. Divide the given shapes as instructed

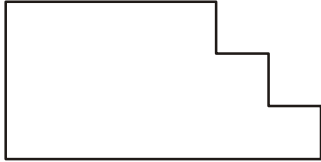

(i) into 3 rectangles

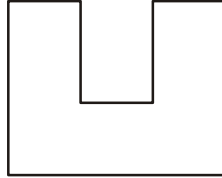

(ii) into 3 rectangles

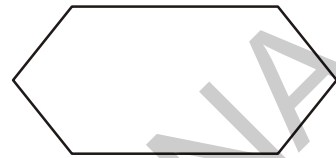

(iii) into 2 trapezium

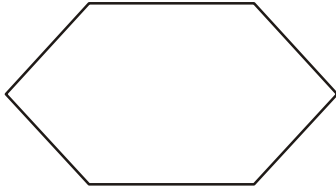

(iv) 2 triangles and a rectangle

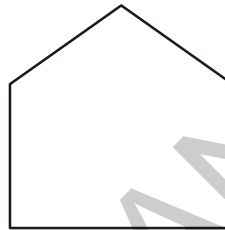

(v) into 3 triangles

2. Find the area enclosed by each of the following figures

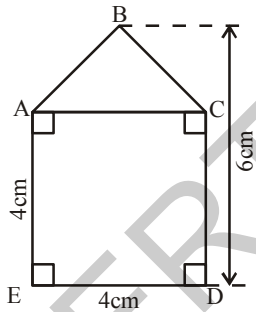

(i)

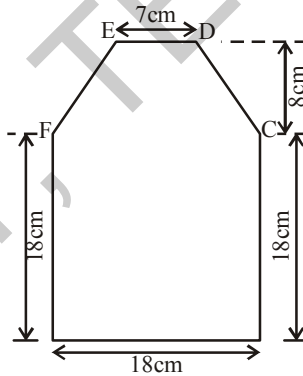

(ii)

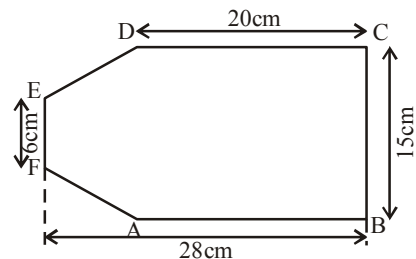

(iii)

3. Calculate the area of a quadrilateral ABCD when length of the diagonal AC = 10 cm and the lengths of perpendiculars from B and D on AC be 5 cm and 6 cm respectively.
4. Diagram of the adjacent picture frame has outer dimensions 28 cm \times 24 cm and inner dimensions 20 cm \times 16 cm. Find the area of shaded part of frame, if width of each section is the same.

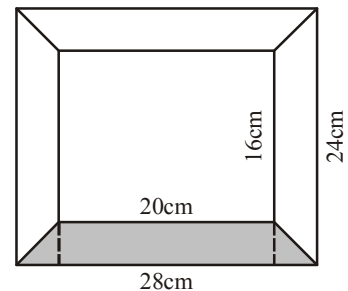

5. Find the area of each of the following fields. All dimensions are in metres.

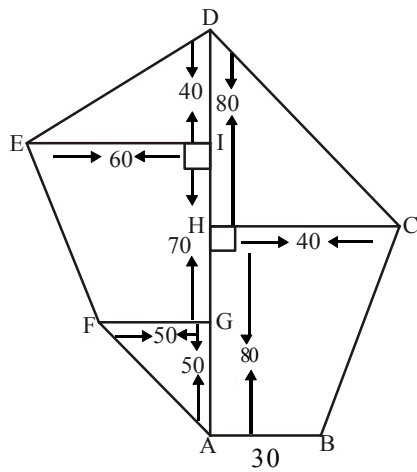

(i)

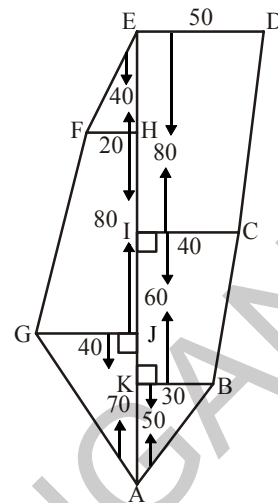

(ii)

6. The ratio of the length of the parallel sides of a trapezium is 5:3 and the distance between them is 16cm. If the area of the trapezium is 960 cm^2 , find the length of the parallel sides.
7. The floor of a building consists of around 3000 tiles which are rhombus shaped and each of its diagonals are 45 cm and 30 cm in length. Find the total cost of flooring if each tile costs rupees 20 per m^2 .
8. There is a pentagonal shaped parts as shown in figure. For finding its area Jyothi and Rashida divided it in two different ways. Find the area in both ways and what do you observe?

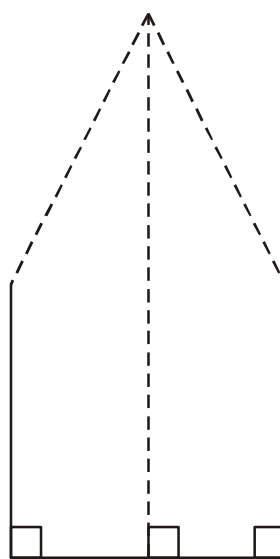
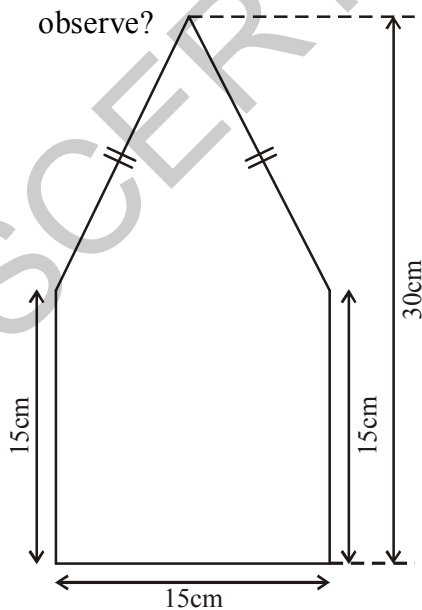

Jyothi Diagram

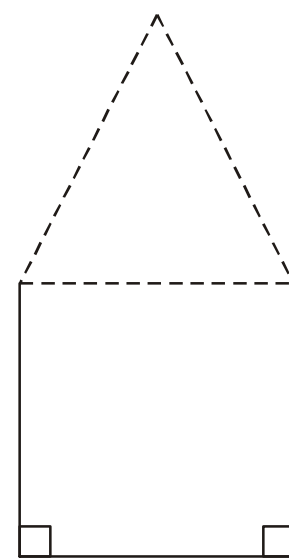

Rashida's Diagram

9.6 Area of circle

Let us find the area of a circle, using graph paper.

Draw a circle of radius 4 cm. on a graph paper . Find the area by counting the number of squares enclosed. As the edges are not straight, we roughly estimate the area of circle by this method. There is another way of finding the area of a circle.

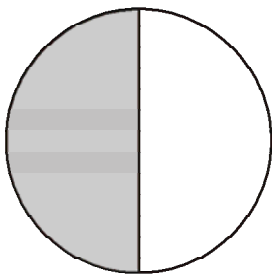
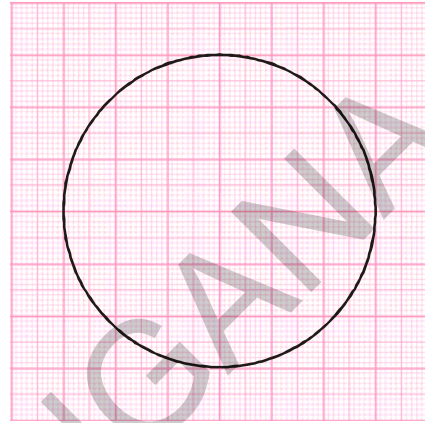

Fig.(i)

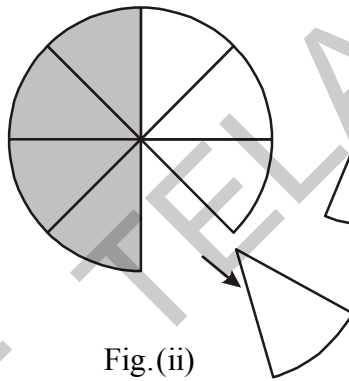

Fig.(ii)

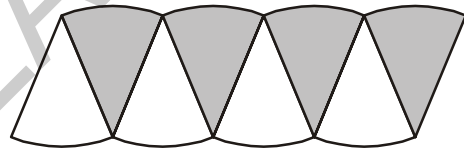

Fig.(iii)

Draw a circle and shade one half of the circle as in (Fig.(i)), now fold the circle into eight equal parts and cut along the folds as in Fig (ii)

Arrange the separate pieces as shown in Fig. (iii), which is roughly a parallelogram. The more sectors we have, the nearer we reach an appropriate parallelogram as done above. If we divide the circle into 64 sectors, and arrange these sectors as shown in figure it forms almost a rectangle Fig(iv)

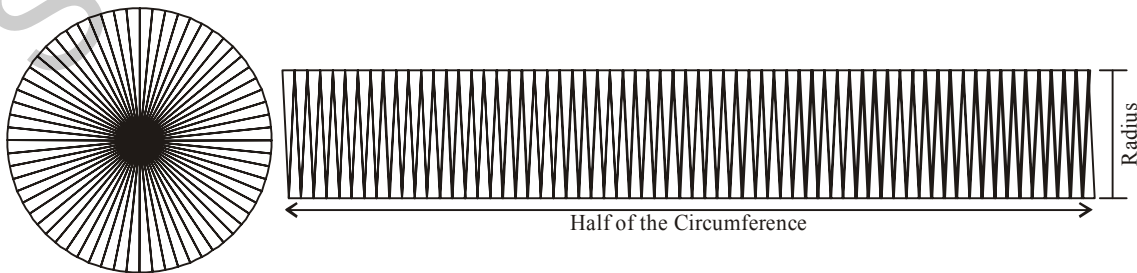

Fig.(iv)

What is the breadth of this rectangle? The breadth of this rectangle is the radius of the circle 'r'
 As the whole circle is divided into 64 sectors and on each side we have 32 sectors, the length of the rectangle is the length of the 32 sectors, which is half of the circumference (Fig.(iv)).

$$\begin{aligned}
 \text{Area of the circle} &= \text{Area of rectangle thus formed} \\
 &= l \times b \\
 &= (\text{half of circumference}) \times \text{radius} \\
 &= \frac{1}{2} \times 2\pi r \times r = \pi r^2
 \end{aligned}$$

So the area of the circle = πr^2

Thread activity:

The commentaries of the Talmud (A book of Jews) presents a nice approach to the formula, $A = \pi r^2$ to calculate the area of a circle. Imagine that the interior of a circle is covered by concentric circles of yarn. Cut the yarn circles along a vertical radius. Each strand is then straightened and arranged as shown in the figure below to form an isosceles triangle

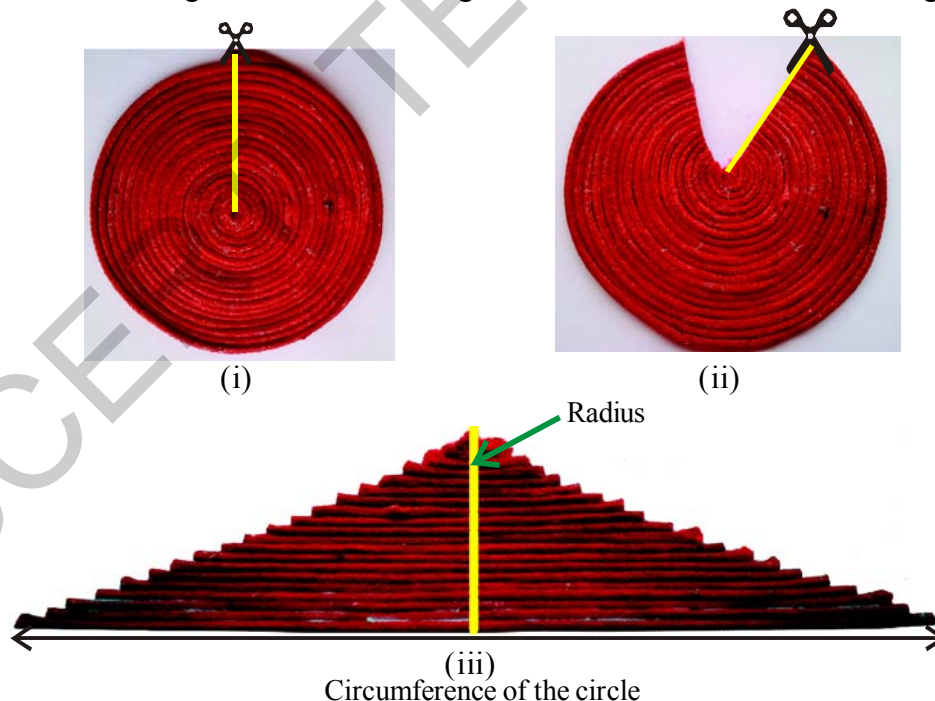

The base of the isosceles triangle is equal to the circumference of the circle and height is equal to the radius of the circle.

$$\text{The area of the triangle} = \frac{1}{2} \times \text{base} \times \text{height}$$

$$= \frac{1}{2} \times 2\pi r \times r$$

$$= \pi r^2$$

\therefore Area of a circle = πr^2 (Where r is the radius of the circle)



Try These

Draw circles having different radius on a graph paper. Find the area by counting the number of squares. Also find the area by using formula. Compare the two answers.

Example 11: A wire is bent into the form of a square of side 27.5 cm. The wire is straightened and bent into the form of a circle. What will be the radius of the circle so formed?

Solution: Length of wire = perimeter of the square

$$= (27.5 \times 4) = 110 \text{ cm.}$$

When the wire is bent into the form of a circle, then it represents the circumference of the circle which would be 110 cm.

Let r be the radius of this circle

$$\text{Thus, circumference} = 2 \times \pi \times r = 110$$

$$= 2 \times \frac{22}{7} \times r = 110$$

$$= \frac{44}{7} \times r = 110$$

$$= 17.5 \text{ cm}$$

Example 12: The circumference of a circle is 22 cm. Find its area and also find the area of the semicircle.

Solution: Let the radius of the circle be r cm

$$\text{Then circumference} = 2\pi r$$

$$\therefore 2\pi r = 22$$

$$2 \times \frac{22}{7} \times r = 22$$

$$r = 22 \times \frac{7}{22} \times \frac{1}{2} = \frac{7}{2} \text{ cm}$$

∴ Radius of the circle = 3.5cm

Area of the circle $\pi r^2 = \left(\frac{22}{7} \times \frac{7}{2} \times \frac{7}{2}\right) = 38.5 \text{ cm}^2$

Area of the semi circle = $\frac{1}{2} \pi r^2 = \frac{1}{2} \times 38.5 = 19.25 \text{ cm}^2$

What is area of Semi-circle?

Imagine, if we fold the circle along its diameter, we get the area of the shaded region. Can we say area of the shaded region is half of area of the circle?

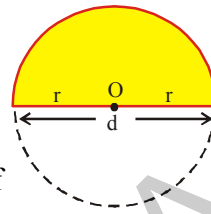

Its area is half of the area of circle = $\frac{1}{2} \pi r^2$
what will be the perimeter of the semi-circle ?

9.7 Area of a Circular Path or Area of a ring

In a park a circular path is laid as shown in the given figure. Its outer and inner circles are concentric. Let us find the area of this circular path.

The Area of the circular path is the difference of Area of outer circle and inner circle.

If we say the radius of outer circle is 'R' and inner circle is 'r' then

Area of the circular path = Area of outer circle – Area of inner circle

$$= \pi R^2 - \pi r^2$$

$$= \pi (R^2 - r^2)$$

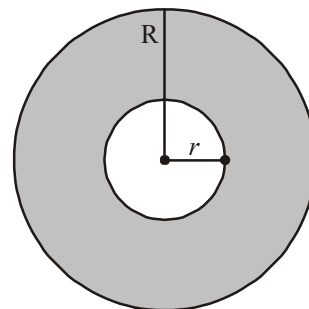

Hence, Area of the circular path or Area of a ring = $\pi (R^2 - r^2)$ or $\pi (R + r) (R - r)$

Where R, r are radii of outer circle and inner circle respectively

Example:13 Observe the adjacent figure. It shows two circles with the same centre. The radius of the larger circle is 10cm and the radius of the smaller circle is 4cm.

- Find
- the area of the larger circle
 - The area of the smaller circle
 - The shaded area between the two circles. (take $\pi = 3.14$)

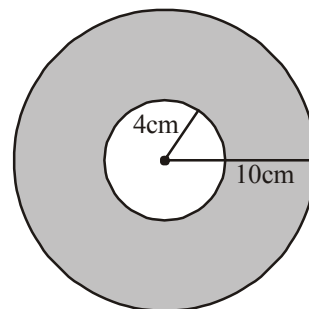

- Solution:**
- (i) Radius of the larger circle = 10 cm
 So, area of the larger circle = πR^2
 $= 3.14 \times 10 \times 10 = 314 \text{ cm}^2$
- (ii) Radius of the smaller circle = 4 cm
 So, area of the smaller circle = πr^2
 $= 3.14 \times 4 \times 4 = 50.24 \text{ cm}^2$
- (iii) Area of the shaded region = Area of the larger circle – Area of the smaller circle
 $= 314 - 50.24$
 $= 263.76 \text{ cm}^2$.

Example 14: Calculate the area of shaded part of the figure given below.

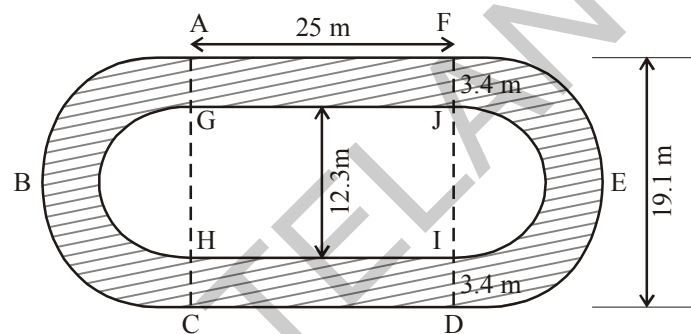

Solution: Shaded Area = Area of rectangle AGJF + Area of rectangle HC DI + Area of semi circular ring ABCHG + Area of semicircular ring DEFJI

$$\text{Area of rectangle AGJF} = 25 \times 3.4 = 85 \text{ m}^2.$$

$$\text{Area of rectangle HC DI} = 25 \times 3.4 = 85 \text{ m}^2.$$

$$\text{Area of a semi circular ring ABCHG} = \frac{\pi}{2} [(R^2 - r^2)] = \frac{22}{7} \times \frac{1}{2} [(9.55)^2 - (6.15)^2]$$

$$\text{Area of a semi circular ring DEFJI} = \frac{\pi}{2} [(R^2 - r^2)] = \frac{22}{7} \times \frac{1}{2} [(9.55)^2 - (6.15)^2]$$

Area of shaded part

$$= (25 \times 3.4) + (25 \times 3.4) + \frac{1}{2} \pi [(9.55)^2 - (6.15)^2] + \frac{1}{2} \pi [(9.55)^2 - (6.15)^2]$$

$$= [85 + 85 + \frac{22}{7} \times 15.7 \times 3.4]$$

$$= (170 + 167.77)$$

$$= 337.77 \text{ m}^2$$

$$R = \frac{19.1}{2} = 9.55$$

$$r = \frac{12.3}{2} = 6.15$$

Example 15: Find the area of shaded region of the figure given below.

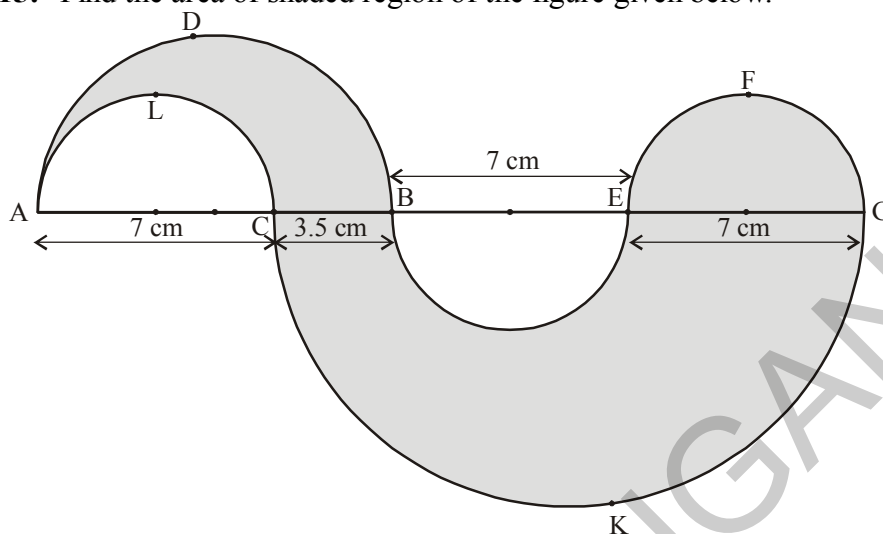

Solution: Shaded area = Area ADBCLA + Area EFGE + Area BEGKCB

$$\begin{aligned}
 &= \frac{1}{2} \times \pi \left[\left(\frac{10.5}{2} \right)^2 - \left(\frac{7}{2} \right)^2 \right] + \frac{1}{2} \pi \left(\frac{7}{2} \right)^2 + \frac{1}{2} \pi \left[\left(\frac{17.5}{2} \right)^2 - \left(\frac{7}{2} \right)^2 \right] \text{ cm}^2 \\
 &= \left(\frac{1}{2} \times \frac{22}{7} \times \frac{35}{4} \times \frac{7}{4} \right) + \left(\frac{1}{2} \times \frac{22}{7} \times \frac{49}{4} \right) + \left(\frac{1}{2} \times \frac{22}{7} \times \frac{21}{4} \times \frac{49}{4} \right) \\
 &= \left(\frac{385}{16} + \frac{77}{4} + \frac{1617}{16} \right) \\
 &= \left(\frac{2310}{16} \right) \\
 &= 144.375 \text{ cm}^2
 \end{aligned}$$

9.8 Length of the arc

Observe the following circles and complete the table

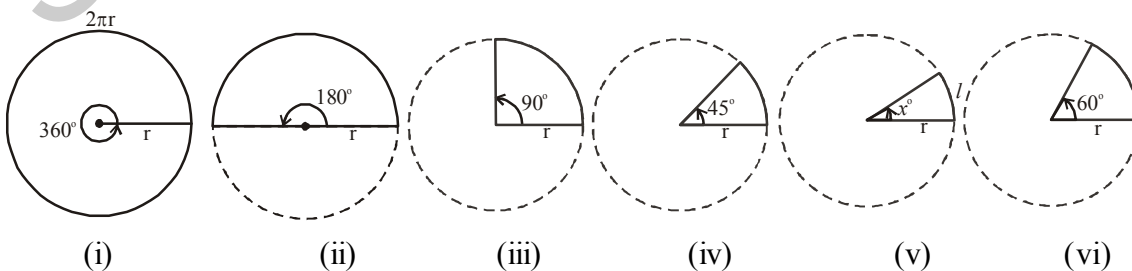

Fig	Angle	Length of Arc	Relation between angle and length of arc
(i)	360°	$2\pi r$	$\frac{360^{\circ}}{360^{\circ}} \times 2\pi r = 2\pi r$
(ii)	180°	πr	$\frac{180^{\circ}}{360^{\circ}} \times 2\pi r = \pi r$
(iii)	90°	$\frac{\pi r}{2}$	_____
(iv)	45°	$\frac{\pi r}{4}$	_____
(v)	x°	l	$\frac{x^{\circ}}{360^{\circ}} \times 2\pi r = l$
(vi)	60°	$\frac{\pi r}{3}$	_____

From the above observations, the length of the arc of a sector (l) = $\frac{x^{\circ}}{360^{\circ}} \times 2\pi r$ where 'r' is the radius of the circle and 'x' is the angle subtended by the arc of the sector at the centre.

If the length of arc of a sector is l

$$\frac{2\pi r}{l} = \frac{360^{\circ}}{x^{\circ}}$$

Then
$$l = \frac{x^{\circ}}{360^{\circ}} \times 2\pi r$$

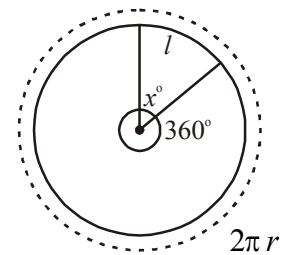

9.9 Area of Sector

We know that part of a circle bounded by two radii and an arc is called sector.

The Area of a circle with radius $r = \pi r^2$

Angle subtended by the arc of the sector at centre of the circle is x°

Area of a sector and its angle are in direct proportion

$$\therefore \text{Area of sector} : \text{Area of circle} = x^{\circ} : 360^{\circ}$$

The area of sector OAB = $\frac{x^{\circ}}{360^{\circ}} \times \text{Area of the circle}$

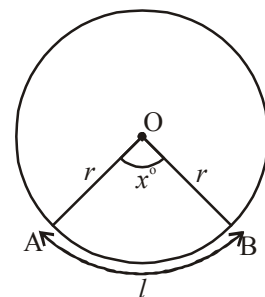

$$\begin{aligned}
 \text{Hence Area of sector OAB} &= \frac{x^\circ}{360^\circ} \times \pi r^2 \left[\pi r^2 = \pi r \times \frac{2r}{2} \right] \\
 &= \frac{x^\circ}{360^\circ} \times 2\pi r \times \frac{r}{2} \\
 &= l \times \frac{r}{2} \\
 A &= \frac{lr}{2} \quad (l \text{ is length of the arc})
 \end{aligned}$$

Example 16: Find the area of shaded region in each of the following figures.

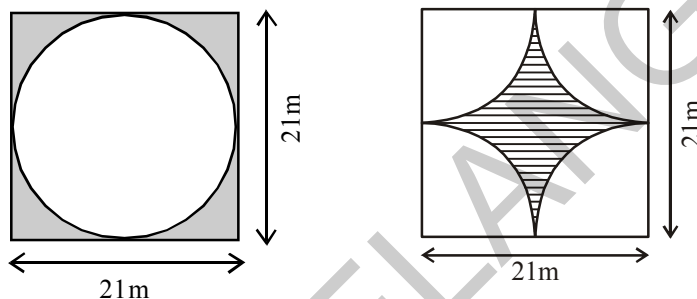

Solution:

(i) Area of the shaded region

$$= (\text{Area of the square with side } 21\text{m}) - (\text{Area of the circle with diameter } 21\text{m})$$

If the diameter of the circle is 21m

$$\text{Then the radius of the circle} = \frac{21}{2} = 10.5\text{m}$$

$$\begin{aligned}
 \text{Area of the shaded region} &= (21 \times 21) - \left(\frac{22}{7} \times \frac{21}{2} \times \frac{21}{2} \right) \\
 &= 441 - 346.5 \\
 &= 94.5 \text{ m}^2
 \end{aligned}$$

(ii) Area of shaded region = (Area of the square with side 21 m) –
(4 × Area of the sector)

$$= (21 \times 21) - \left(4 \times \frac{90^\circ}{360^\circ} \times \frac{22}{7} \times \frac{21}{2} \times \frac{21}{2} \right)$$

(If diameter is 21m, then radius is $\frac{21}{2}$ m)

$$\begin{aligned}
 &= (21 \times 21) - \left(4 \times \frac{1}{4} \times \frac{22}{7} \times \frac{21}{2} \times \frac{21}{2} \right) \\
 &= (441 - 346.5) \\
 &= 94.5 \text{ m}^2
 \end{aligned}$$



Exercise - 9.2

1. A rectangular acrylic sheet is 36 cm by 25 cm. From it, 56 circular buttons, each of diameter 3.5 cm have been cut out. Find the area of the remaining sheet.
2. Find the area of a circle inscribed in a square of side 28 cm.

[Hint. Diameter of the circle is equal to the side of the square]

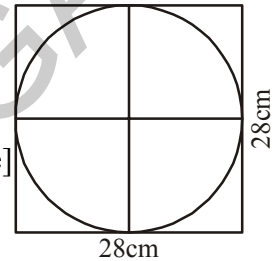

3. Find the area of the shaded region in each of the following figures.

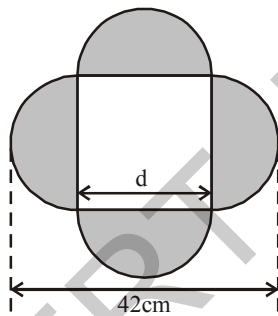

[Hint: $d + \frac{d}{2} + \frac{d}{2} = 42$]

$$d = 21$$

\therefore side of the square 21 cm

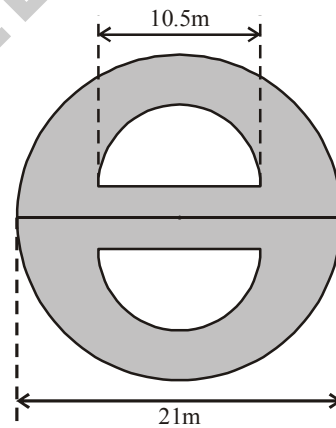

4. The adjacent figure consists of four small semi-circles of equal radii and two big semi-circles of equal radii (each 42 cm). Find the area of the shaded region.

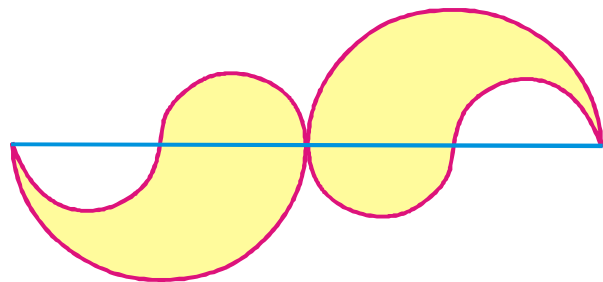

5. The adjacent figure consists of four half circles and two quarter circles. If $OA = OB = OC = OD = 14$ cm. Find the area of the shaded region.

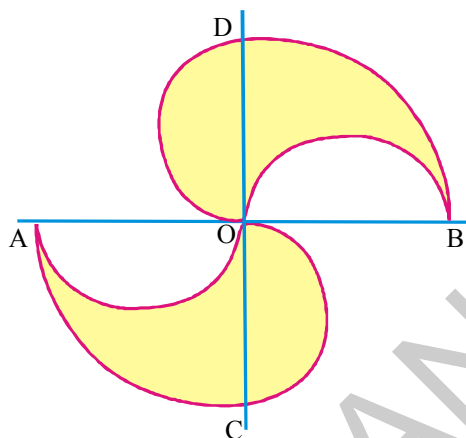

6. In adjacent figure A, B, C and D are centres of equal circles which touch externally in pairs and ABCD is a square of side 7 cm. Find the area of the shaded region.

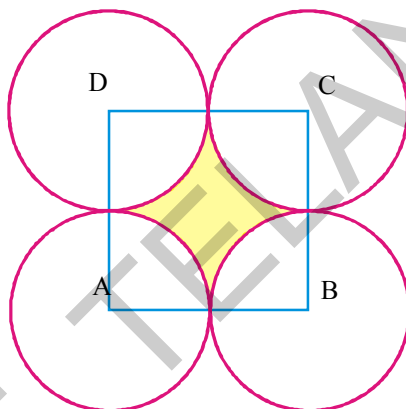

7. The area of an equilateral triangle is $49\sqrt{3}$ cm². Taking each angular point as centre, a circle is described with radius equal to half the length of the side of the triangle as shown in the figure. Find the area of the portion in the triangle not included in the circles.

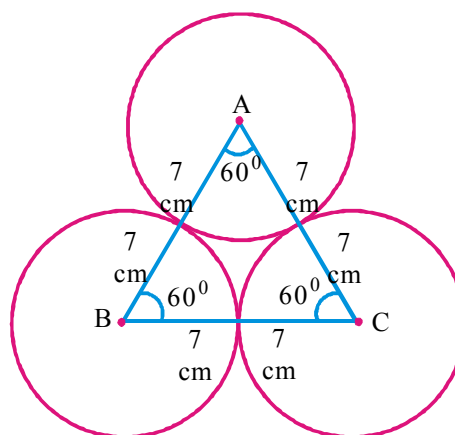

- 8.(i) Four equal circles, each of radius 'a' touch one another. Find the area between them.
 (ii) Four equal circles are described about the four corners of a square so that each circle touches two of the others. Find the area of the space enclosed between the circumferences of the circles, each side of the square measuring 24 cm.

9. In adjacent figure ABCD, is a trapezium and $AB \parallel CD$ and $\angle BCD = 90^\circ$, quarter circle is removed. Given $AB = BC = 3.5$ cm and $DE = 2$ cm. Calculate the area of the remaining portion.

(Take π to be $\frac{22}{7}$)

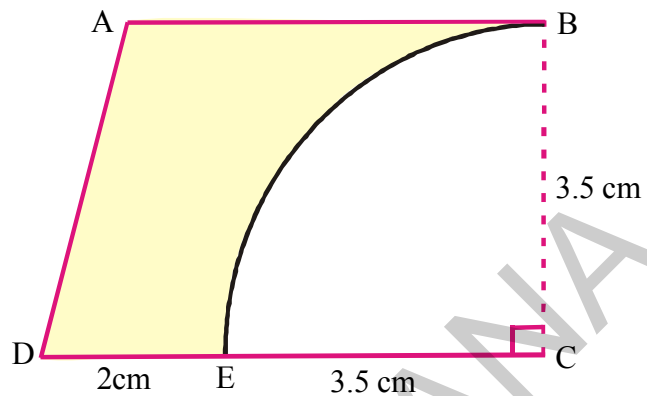

10. A horse is placed for grazing inside a rectangular field 70 m by 52 m and is tethered to one corner by a rope 21 m long. How much area can it graze?

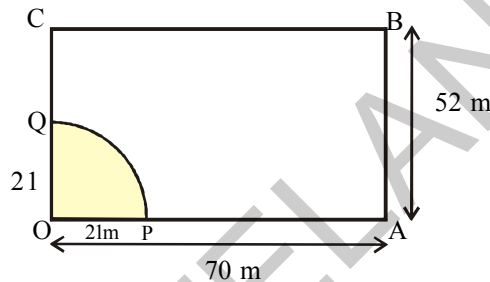

What we have discussed

- Area of a trapezium = $\frac{1}{2}$ (Sum of the lengths of parallel sides) \times (Distance between them)
- Area of a quadrilateral = $\frac{1}{2} \times$ length of a diagonal \times Sum of the lengths of the perpendiculars from the remaining two vertices on the diagonal)
- Area of a rhombus = Half of the product of diagonals.
- Area of a circle = πr^2 where 'r' is the radius of the circle.
- Area of a circular path (or) Area of a Ring = $\pi(R^2 - r^2)$ or $\pi(R + r)(R - r)$ where R, r are radii of outer circle and inner circle respectively.
- Area of a sector = $\frac{x^\circ}{360^\circ} \times \pi r^2$ where x° is the angle subtended by the arc of the sector at the center of the circle and r is radius of the circle.

$$A = \frac{l r}{2}. \text{ Where } l - \text{length of the arc, } r - \text{radius of the circle}$$



Direct and Inverse Proportions



S1C2K3

10.0 Introduction

Let us consider the following situation, Gopi uses 4 cups of water to cook 2 cups of rice everyday. One day when some guests visited his house, he needed to cook 6 cups of rice. How many cups of water will he need to cook 6 cups of rice? Can you help him?

We come across many such situations in our day-to-day life, where we observe changes in one quantity brings change in other quantity. For example,

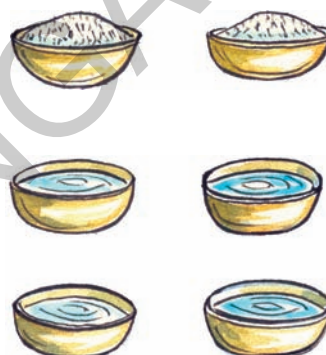

- What happens to the quantity of mid day meal needed if more number of students are enrolled in your school? More quantity of mid day meal is required.
- If we deposit more money in a bank, what can you say about the interest earned? Definitely the interest earned also will be more.
- What happens to the total cost, if the number of articles purchased decreases? Obviously the total cost also decreases.
- What is the weight of 20 tea packets, if the weight of 40 tea packets is 1.6 kg? Clearly the weight of 20 tea packets is less.

In the above examples, we observe that variation in one quantity leads to variation in the other quantity.



Do This

Write five more such situations where change in one quantity leads to change in another quantity.

How do we find out the quantity of water needed by Gopi? To answer this question, now we will discuss some variations.

10.1 Direct Proportion

On the occasion of Vanamahotsavam, Head of Eco team in a school decided to take up plantation of saplings. Number of Eco club members of each class is furnished here.

Class	VI	VII	VIII	IX	X
Number of Eco students	5	7	10	12	15

Each student has to plant two saplings. Find the number of saplings needed for plantation for each class.



Class	VI	VII	VIII	IX	X
Number of Eco students	5	7	10	12	15
Number of saplings required	10	14	20	24	30

What can you say regarding the number of saplings required? What kind of a change do you find in the number of saplings required and the number of students? Either both increase or decrease.

$$\frac{\text{Number of saplings required}}{\text{Number of students}} = \frac{10}{5} = \frac{14}{7} = \frac{20}{10} = \dots = \frac{2}{1} = 2 \text{ which is a constant and is}$$

called constant of proportion.

As the ratio is same, we call this variation as direct proportion.

If x and y are any two quantities such that both of them increase or decrease together and $\frac{x}{y}$ remains constant (say k), then we say that x and y are in direct proportion. This can be written as $x \propto y$ and read as x is directly proportional to y .

$$\therefore \frac{x}{y} = k \Rightarrow x = ky \text{ where } k \text{ is constant of proportion.}$$

If y_1 and y_2 are the values of y corresponding to the values of x_1 and x_2 of x respectively,

$$\text{then } \frac{x_1}{y_1} = \frac{x_2}{y_2}$$



Do These

1. Write three situations from your daily life in which you see direct proportion.
2. Let us consider different squares of sides 2, 3, 4 and 5cm, Find the areas of the squares and fill the table.

Side in cm	Area in cm^2
2	
3	
4	
5	

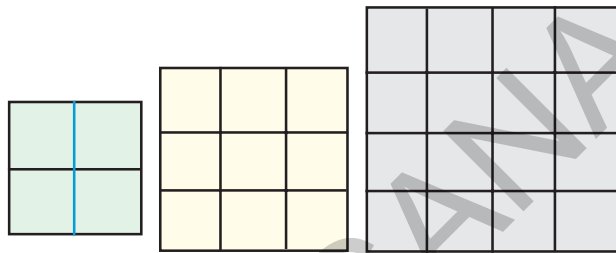

What do you observe? Do you find any change in the area of the square with a change in its side? Further, find the ratio of area of a square to the length of its side. Is the ratio same? Obviously not! This variation is not a direct proportion.

3. The following are rectangles of equal breadth on a graph paper. Find the area for each rectangle and fill in the table.

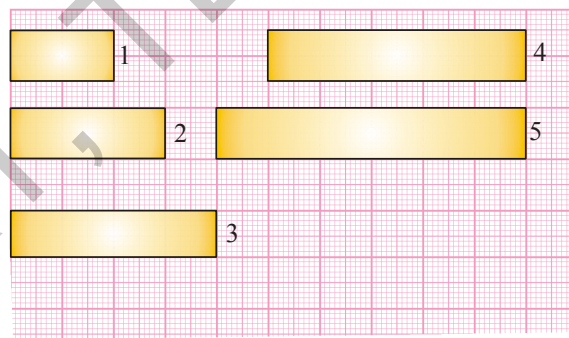

Rectangle	1	2	3	4	5
Length (cm)					
Area (cm^2)					

Is the area directly proportional to length?

4. Take a graph paper make same rectangles of same length and different width. Find the area for each. What can you conclude about the breadth and area?

Example 1: If the cost of 65 tea-packets of same size is ₹ 2600, what is the cost of 75 such packets?

Solution: We know if the number of tea packets purchased increases then the cost also increases. Therefore, cost of tea-packets directly varies with the number of teapackets.

No. of tea packets (x)	65	75
Cost (y)	2600	?

So $\frac{x_1}{y_1} = \frac{x_2}{y_2}$ Here $x_1 = 65$ $y_1 = 2600$ $x_2 = 75$ $y_2 = ?$

by substituting; $\frac{65}{2600} = \frac{75}{y_2} \Rightarrow y_2 = \frac{75 \times 2600}{65} = ₹ 3000$

So cost of 75 such packets is ₹ 3000.

Example 2: Following are the car parking charges near a railway station

Number of Hours (x)	Parking Charge (y)
upto 4 hours	₹ 60
8 hours	₹ 100
12 hours	₹ 140
24 hours	₹ 180

Check if the parking charges and parking hours are in direct proportion.

Solution: We can observe that both values are gradually increasing.

Are they in direct proportion? What is the value of $\frac{x}{y}$?

If it is a constant, then they are in direct proportion. Otherwise they are not in direct proportion. Let's check in this case.

$$\frac{x}{y} = \frac{4}{60}, \frac{8}{100}, \frac{12}{140}, \frac{24}{180}$$

You can easily observe that all these ratios are not equal. So they are not in direct proportion.

Example 3: A pole of 8 m height casts a 10m long shadow. Find the height of the tree that casts a 40 m long shadow under similar conditions.

Solution: Length of a shadow directly varies to the height of the pole.

So $\frac{x_1}{y_1} = \frac{x_2}{y_2}$ Here $x_1 = 8m$ $y_1 = 10m$ $x_2 = ?$ and $y_2 = 40m$

Substitute $\frac{8}{10} = \frac{x_2}{40} \Rightarrow x_2 = \frac{8 \times 40}{10} = 32 m$

So height of the tree is 32 m.

Example 4: If a pipe can fill a tank of capacity 50 l in 5 hours. Then how long will it take to fill a tank of capacity 75l.

Solution: Volume of water in a tank \propto time required to fill it.

So here $\frac{x_1}{y_1} = \frac{x_2}{y_2}$ Here $x_1 = 50 l$ $y_1 = 5hr$ $x_2 = 75 l$ and $y_2 = ?$

$\frac{50}{5} = \frac{75}{y_2} \Rightarrow y_2 = \frac{75 \times 5}{50} = \frac{375}{50} = 7\frac{1}{2} hr$

Time required to fill a tank of capacity 75 l is $7\frac{1}{2}$ hr

Example 5: If the cost of 20m of a cloth is ₹ 1600, then what will be the cost of 24.5 m of that cloth.

Solution: Cost directly varies with the length of cloth.

So $\frac{x_1}{y_1} = \frac{x_2}{y_2}$ where $x_1 = 20 m$ $y_1 = ₹ 1600$, $x_2 = 24.5 m$ and $y_2 = ?$

By substituting; $\frac{20}{1600} = \frac{24.5}{y_2} \Rightarrow y_2 = \frac{1600 \times 24.5}{20} = 1960$

Cost of 24.5 m of cloth is ₹ 1960.



Measure the distance in the given map; and by using that calculate actual distance between (i) Vijayawada and Vishakapattanam, (ii) Tirupati and Warangal (scale is given). Scale shows how the lengths between two cities are reduced in drawing

Scale : 1 cm = 300 km
 Converting the scale to ratio we get
 1 cm : 30000000 cm.

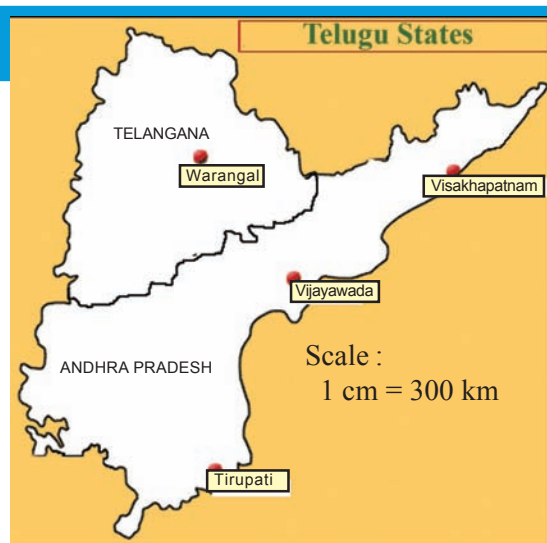



Exercise - 10.1

1. The cost of 5 meters of a particular quality of cloth is ₹ 210. Find the cost of (i) 2m (ii) 4m (iii) 10m (iv) 13m of cloth of the same quality.

2. Fill the table.

No. of Apples	1	4	7	12	20
Cost of Apples (in ₹)	8

3. 48 bags of paddy costs ₹ 16, 800 then find the cost of 36 bags of paddy.
4. Monthly average expenditure of a family with 4 members is ₹ 2,800. Find the monthly average expenditure of a family with only 3 members.
5. In a ship of length 28 m, height of its mast is 12 m. If the height of the mast in its model is 9 cm what is the length of the model ship?
6. A vertical pole of 5.6 m height casts a shadow 3.2 m long. At the same time find (i) the length of the shadow cast by another pole 10.5 m high (ii) the height of a pole which casts a shadow 5m long.
7. A loaded truck travels 14 km in 25 minutes. If the speed remains the same, how far can it travel in 5 hours?
8. If the weight of 12 sheets of thick paper is 40 grams, how many sheets of the same paper would weigh $16\frac{2}{3}$ kilograms?
9. A train moves at a constant speed of 75 km/hr.
(i) How far will it travel in 20 minutes?
(ii) Find the time required to cover a distance of 250 km.
10. The design of a microchip has the scale 40:1. The length of the design is 18cm, find the actual length of the micro chip?
11. The average age of doctors and lawyers together is 40. If the doctors average age is 35 and the lawyers average age is 50, find the ratio of the number of doctors to the number of lawyers.



Project work

1. Take a map of India. Note the scale used there. Measure the map distance between any two cities using a scale. Calculate the actual distance between them.
2. The following ingredients are required to make halwa for 5 persons: Suji / Rawa=250 g, Sugar = 300 g, Ghee = 200 g, Water = 500 ml. Using the concept of proportion, estimate the changes in the quantity of ingredients, to prepare halwa for your class.

10.2 Inverse Proportion

A parcel company has certain number of parcels to deliver. If the company engages 36 persons, it takes 12 days. If there are only 18 persons, it will take 24 days to finish the task. Here we observe that as the number of persons is halved, the time taken is doubled. If the company engages 72 persons, will the time taken be halved?

Observe the following table.

No. of persons	36	18	9	72	108
Time taken	12	24	48	6	4

Diagram illustrating the relationships between the values in the table:

- From 36 to 18: $\div 2$
- From 18 to 9: $\div 2$
- From 9 to 72: $\times 8$ (or $\times 2$ then $\times 4$)
- From 72 to 108: $\times 1.5$ (or $\times 3$ then $\div 2$)
- From 12 to 24: $\times 2$
- From 24 to 48: $\times 2$
- From 48 to 6: $\div 8$ (or $\div 4$ then $\div 2$)
- From 6 to 4: $\div 1.5$ (or $\div 3$ then $\times 2$)

How many persons shall the company engage if it intends to deliver the parcels within a day?

Two quantities change in such a manner that, if one quantity increases, the other quantity decreases in the same proportion and vice versa. This is called inverse proportion. In the above example, the number of persons engaged and number of days are inversely proportional to each other.

Symbolically, this is expressed as

$$\text{number of days required} \propto \frac{1}{\text{number of persons engaged}}$$

If x and y are in inverse proportion then $x \propto \frac{1}{y}$

$x = \frac{k}{y}$ where k is constant of proportionality.

$$xy = k.$$

If y_1 and y_2 are the values of y corresponding to the values x_1 and x_2 of x respectively

then $x_1 y_1 = x_2 y_2 (= k)$, or $\frac{x_1}{x_2} = \frac{y_2}{y_1}$.



Do These

- Write three situations from your day-to-day life where you see inverse proportion.
- To make rectangles of different dimensions on a squared paper using 12 adjacent squares. Calculate length and breadth of each of the rectangles so formed. Note down the values in the following table.

Rectangle Number	Length (in cm)	Breadth (in cm)	Area (sq. cm)
1	l_1	b_1
2	l_2	b_2
3	l_3	b_3
4	l_4	b_4
5	l_5	b_5
6	l_6	b_6

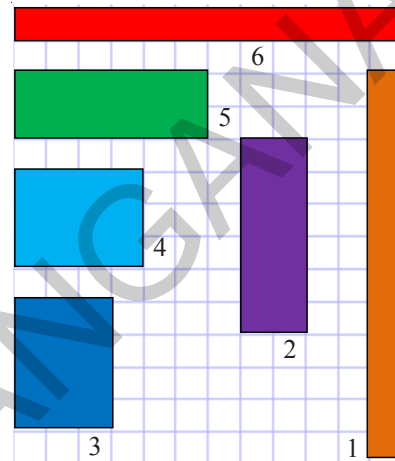

What do you observe? As length increases, breadth decreases and vice-versa (for constant area).

In each case, are length and breadth inversely proportional to each other?

Example 6: If 36 workers can build a wall in 12 days, how many days will 16 workers take to build the same wall? (assuming the number of working hours per day is constant)

Solution: If the number of workers decreases, the time taken to build the wall increases in the same proportion. Clearly, number of workers varies inversely to the number of days.

So here $\frac{x_1}{x_2} = \frac{y_2}{y_1}$ where $x_1 = 36$ workers
 $y_1 = 12$ days $x_2 = 16$ workers
 and $y_2 = (?)$ days

No. of workers	No. of days
↓ 36	↑ 12
↓ 16	↑ y_2

Since the number of workers are decreasing

$$36 \div x = 16 \Rightarrow x = \frac{36}{16}$$

So the number of days will increase in the same proportion.

$$\text{i.e. } x \times 12 = \frac{36}{16} \times 12 \\ = 27 \text{ days}$$

Substitute, $\frac{36}{16} = \frac{y_2}{12} \Rightarrow y_2 = \frac{12 \times 36}{16} = 27$ days.

Therefore 16 workers will build the same wall in 27 days.



Think Discuss and Write

Can we say that every variation is a proportion?

A book consists of 100 pages. How do the number of pages read and the number of pages left over in the book vary?

No. of pages read (x)	10	20	30	50	70
No. of left over pages (y)	90	80	70	50	30

What happened to the number of left over pages, when completed pages are gradually increasing? Do they vary inversely? Explain.



Exercise - 10.2

Observe the following tables and find which pair of variables (x and y) are in inverse proportion

(i)

x	50	40	30	20
y	5	6	7	8

(ii)

x	100	200	300	400
y	60	30	20	15

(iii)

x	90	60	45	30	20	5
y	10	15	20	25	30	25

2. A school wants to spend ₹ 6000 to purchase books. Using this data, fill the following table.

Price of each book (in ₹)	40	50		75	
Number of books that can be purchased	150		100		75

3. Take a squared paper and arrange 48 squares in different number of rows as shown below:

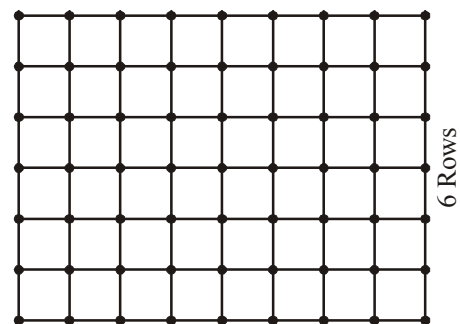
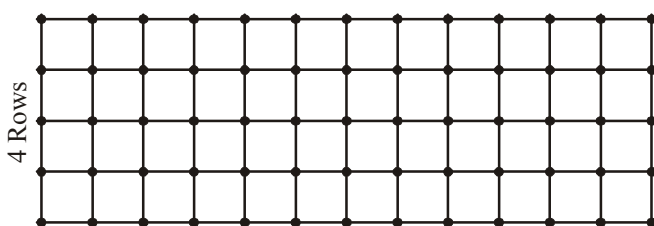

Number of Rows (R)	2	3	4	6	8
Number of Columns (C)	---	---	12	8	---

What do you observe? As R increases, C decreases

- Is $R_1 : R_2 = C_2 : C_1$?
- Is $R_3 : R_4 = C_4 : C_3$?
- Is R and C inversely proportional to each other?
- Do this activity with 36 squares.

Classroom Project		Day of the week	Number of students present (x)	Number of students absent (y)	x : y
Prepare a table with number of students present and number of students absent in your class for a week. Discuss with your friends and write your observations in your note book.	Monday				
	Tuesday				
	Wednesday				
	Thursday				
	Friday				
	Saturday				
	Sunday				

Now let us solve some examples.

Example 7: Ration is available for 100 students in a hostel for 40 days. How long will it last, if 20 more students join in the hostel after 4 days?

Solution: As the number of students increases the ration will last for less number of days in the same proportions. The no. of students and no. of days are in inverse proportion.

	No. of days ration available	No. of students
	40 ↓	↑ 100
After 4 days	36 ↓	100
	x ↓	120

Now the question is; if the ration is available for 36 days for 100 students. How long will it last for 120 students.

$$\frac{36}{x} = \frac{120}{100}$$

$$x = \frac{36 \times 100}{120} = 30 \text{ days}$$

Since the number of students are increasing

$$100 \times x = 120 \Rightarrow x = \frac{120}{100}$$

So the number of days will decrease in same proportion.

$$\text{i.e. } 36 \div x$$

$$= 36 \div \frac{120}{100}$$

$$\Rightarrow 36 \times \frac{100}{120} = 30 \text{ days}$$

Example 8: A car takes 4 hours to reach the destination by travelling at a speed of 60 km/h. How long will it take if the car travels at a speed of 80 km/h?

Solution: As speed increases, time taken decreases in same proportion. So the time taken varies inversely to the speed of the vehicle, for the same distance.

method 1		method 2	
Speed	Time	Speed	Time
60	4	$x \times \left(\begin{array}{c} 60 \\ 80 \end{array} \right)$	$\left. \begin{array}{c} 4 \\ y \end{array} \right) \div x$
80	x		
$\frac{60}{80} = \frac{x}{4}$		(or) $60 \times x = 80$ and $4 \div x = y$	
$60 \times 4 = 80 \times x$		$x = \frac{80}{60}$	
$x = \frac{60 \times 4}{80} = 3 \text{ hr.}$		$4 \div \frac{80}{60} = y$	
		$y = \frac{4 \times 60}{80} = 3 \text{ hr.}$	

Example 9: 6 pumps are required to fill a tank in 1 hour 20 minutes. How long will it take if only 5 pumps of the same type are used?

Solution: Let the desired time to fill the tank be x minutes. Thus, we have the following table.

Number of pumps	6	5
Time (in minutes)	80	x

Lesser the number of pumps, more will be the time required by them to fill the tank.

So, this is a case of inverse proportion.

$$\text{Hence, } 80 \times 6 = x \times 5 \quad [x_1 y_1 = x_2 y_2]$$

$$\text{or } \frac{80 \times 6}{5} = x$$

$$\text{or } x = 96 \text{ minutes.}$$

Thus, time taken to fill the tank by 5 pumps is 96 minutes or 1 hour 36 minutes.

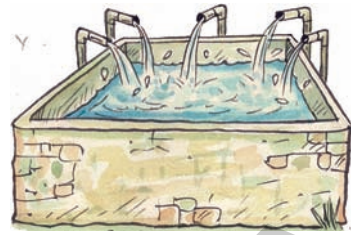

5 pipes in a tank

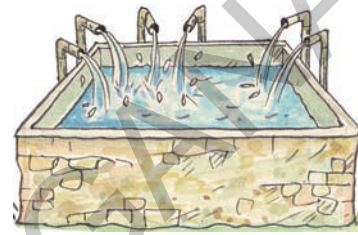

6 pipes in a tank



Exercise - 10.3

1. Siri has enough money to buy 5 kg of potatoes at the price of ₹ 8 per kg. How much can she buy for the same amount if the price is increased to ₹ 10 per kg?
2. A camp has food stock for 500 people for 70 days. If 200 more people join the camp, how long will the stock last?
3. 36 men can do a piece of work in 12 days. In how many days 9 men can do the same work?
4. A tank can be filled by 5 pipes in 80 minutes. How long will it take to fill the tank by 8 pipes of the same size?
5. A ship can cover a certain distance in 10 hours at a speed of 16 nautical miles per hour. By how much should its speed be increased so that it takes only 8 hours to cover the same distance? (1 nautical mile = 1852 metres).
6. 5 pumps are required to fill a tank in $1\frac{1}{2}$ hours. How many pumps of the same type are used to fill the tank in half an hour.
7. If 15 workers can build a wall in 48 hours, how many workers will be required to do the same work in 30 hours?
8. A School has 8 periods a day each of 45 minutes duration. How long would each period become, if the school has 6 periods a day? (assuming the number of school hours to be the same)

9. If z varies directly as x and inversely as y . Find the percentage increase in z due to an increase of 12% in x and a decrease of 20% in y .
10. If $x + 1$ men will do the work in $x + 1$ days, find the number of days that $(x + 2)$ men can finish the same work.
11. Given a rectangle with a fixed perimeter of 24 meters, if we increase the length by 1m the width and area will vary accordingly. Use the following table of values to look at how the width and area vary as the length varies.

What do you observe? Write your observations in your note books

Length(in cm)	1	2	3	4	5	6	7	8	9
Width(in cm)	11	10
Area (in cm^2)	11	20

10.3 Compound Proportion

Some times change in one quantity depends upon the change in two or more quantities in some proportion. Then we equate the ratio of the first quantity to the compound ratio of the other two quantities.

- (i) One quantity may be in direct proportion with the other two quantities.
- (ii) One quantity may be in inverse proportion with the other two quantities
- (iii) One quantity may be in direct proportion with the one of the two quantities and in inverse proportion with the remaining quantity.

Example 10: Consider the mess charges for 35 students for 24 days is ₹ 6300. How much will be the mess charges for 25 students for 18 days.

Solution: Here, we have three quantities i.e mess charges, number of students and number of days.

Mess charges in ₹	Number of students	Number of days
6300	35	24
? (x)	25	18
$6300 : x$	$35:25 = 7:5$	$24:18 = 4:3$

Mess charges is directly proportional to number of students.

Mess charges \propto number of students.

$$6300 : x = 7:5$$

Again mess charges are directly proportional to number of days.

Mess charges \propto number of days.

$$6300 : x = 4 : 3$$

Since, mess charges depends upon both the values i.e number of students and number of days so we will take a compound ratio of these two variables.

Mess charges \propto compound ratio of ratio of number of students and ratio of number of days.

$$6300 : x = \text{compound ratio of } 7 : 5 \text{ and } 4 : 3$$

$$6300 : x = 7 \times 4 : 5 \times 3$$

$$\overbrace{6300 : x} = \underbrace{28 : 15}$$

Product of means = product of extremes.

$$28 \times x = 15 \times 6300$$

$$x = \frac{15 \times 6300}{28}$$

$$x = ₹ 3375.$$

Hence, the required mess charges is ₹ 3375.

Example 11: 24 workers working 6 hours a day can finish a piece of work in 14 days. If each worker works 7 hours a day, find the number of workers to finish the same piece of work in 8 days.

Solution: Here we have three quantities i.e number of workers, number of hours per day and number of days.

No. of workers	No. of hours per day	No. of days
24	6	14
? (x)	7	8
$24 : x$	$6 : 7$	$14 : 8 = 7 : 4$

Number of workers inversly proportional to number of hours per day.

$$\text{Number of workers} \propto \frac{1}{\text{number of hours per day}}$$

$$24 : x = \text{inverse ratio of } 6 : 7 \text{ i.e. } 7 : 6$$

$\Rightarrow 24 : x$ is directly proportional to $7 : 6$.

Again, number of days is inversely proportional to number of workers.

$$\text{Number of workers} \propto \frac{1}{\text{number of days}}$$

$24 : x =$ inverse ratio of $7 : 4$ i.e. $4 : 7$

As, number of workers depends upon two variables i.e number of days and number of hours per day. Therefore,

Number of workers \propto compound ratio of inverse ratio of number of hours per day and inverse ratio of number of days.

$24 : x =$ compound ratio of $7 : 6$ and $4 : 7$

$$24 : x = 7 \times 4 : 6 \times 7$$

$$24 : x = 4 : 6$$

$$\begin{array}{c} \boxed{} \\ 24 : x = 2 : 3 \end{array}$$

Product of means = product of extremes.

$$2 \times x = 24 \times 3$$

$$x = 36$$

Hence the required number of workers = 36.

Alternate method

$$\frac{24}{x} = \frac{7}{6} \times \frac{4}{7}$$

$$\frac{24}{x} = \frac{2}{3}$$

$$2 \times x = 24 \times 3$$

$$x = \frac{72}{2} = 36$$

Example 12: 12 painters can paint a wall of 180 m long in 3 days. How many painters are required to paint 200 m long wall in 5 days?

Solution: Here number of painters are in direct proportion to length of the wall and inversely proportional to the number of days.

No. of painter	Length of the wall (m)	No. of days
12	180	3
x	200	5
$12 : x$	$180 : 200 = 9 : 10$	$3 : 5$

Number of painters \propto length of the wall

$$12 : x = 9 : 10 \quad \text{---- (1) and}$$

$$\text{Number of painters} \propto \frac{1}{\text{number of days}}$$

$12 : x =$ inverse ratio of $3 : 5$

$$12 : x = 5 : 3 \text{ ---- (2)}$$

from (1) and (2)

$12 : x =$ compound ratio of $9 : 10$ and $5 : 3$

$$12 : x = (9 : 10) \times (5 : 3)$$

$$12 : x = 9 \times 5 : 10 \times 3$$

$$12 : x = 45 : 30 = 3 : 2$$

$$\overbrace{12 : x} = \overbrace{3 : 2} \text{ (product of extremes = product of means)}$$

$$3 \times x = 12 \times 2$$

$$x = \frac{24}{3} = 8$$

Number of painters required = 8

Alternate method

$$\frac{12}{x} = \frac{9}{10} \times \frac{5}{3}$$

$$\frac{12}{x} = \frac{3}{2}$$

$$12 \times 2 = 3 \times x$$

4

$$x = \frac{12 \times 2}{3} = 8$$



Exercise - 10.4

1. Rice costing ₹ 480 is needed for 8 members for 20 days. What is the cost of rice required for 12 members for 15 days ?
2. 10 men can lay a road of 75 km. long in 5 days. In how many days can 15 men lay a road of 45 km. long ?
3. 24 men working at 8 hours per day can do a piece of work in 15 days. In how many days can 20 men working at 9 hours per day can complete the same work ?
4. 175 men can dig a canal 3150 m long in 36 days. How many men are required to dig a canal 3900 m. long in 24 days?
5. 14 typists typing 6 hours a day can take 12 days to complete the manuscript of a book. How many days will 4 typists, working 7 hours a day, can take to do the same job?



What we have discussed

- If x and y are in direct proportion, the two quantities vary in the same ratio i.e. if $\frac{x}{y} = k$ or $x = ky$. We can write $\frac{x_1}{y_1} = \frac{x_2}{y_2}$ or $x_1 : y_1 = x_2 : y_2$ [y_1, y_2 are values of y corresponding to the values x_1, x_2 of x respectively]
- Two quantities x and y are said to vary in inverse proportion, if there exists a relation of the type $xy = k$ between them, k being a constant. If y_1, y_2 are the values of y corresponding to the values x_1 and x_2 of x respectively, then $x_1 y_1 = x_2 y_2 (= k)$, or $\frac{x_1}{x_2} = \frac{y_2}{y_1}$.
- If one quantity increases (decreases) as the other quantity decreases (increases) in same proportion, then we say it varies in the inverse ratio of the other quantity. The ratio of the first quantity ($x_1 : x_2$) is equal to the inverse ratio of the second quantity ($y_1 : y_2$). As both the ratios are the same, we can express this inverse variation as proportion and it is called inverse proportion.
- Sometimes change in one quantity depends upon the change in two or more other quantities in same proportion. Then we equate the ratio of the first quantity to the compound ratio of the other two quantities.



Diffy with fractions

The process in this activity is called Diffy. The name comes from the process of taking successive differences of numbers and the activity provides practicing skills in subtraction.

Directions:

Step 1 : Make an array of circles as shown and choose four fractions in the top four circles

Step 2 : In the first three circles of the second row write the difference of the fractions above and to the right and left of the circle in the question, always being careful to subtract the smaller of these two fractions from the larger. In the fourth circle of second row place the difference of fractions in the first and fourth circles in the preceding row, again always subtracting the smaller fraction from the larger.

Step 3 : Repeat step 2 to fill the successive rows of the circles. You may stop if you obtain a row of zeros.

Step 4 : Repeat steps 1, 2 and 3 several times and each time start with different fractions.

Try Fraction Diffy with the fractions in first row $\frac{2}{7}, \frac{4}{5}, \frac{3}{2}, \frac{5}{6}$

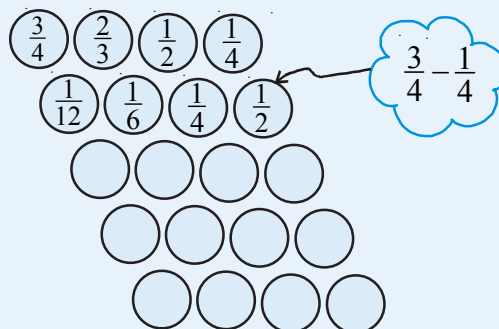



S3F4Y9

11.0 Introduction

Observe the following expressions.

(i) $3 + 8 - 9$ (ii) $\frac{1}{3}xy$ (iii) 0 (iv) $3x + 5$ (v) $4xy + 7$ (vi) $15 + 0 - 19$ (vii) $\frac{3x}{y}$ ($y \neq 0$)

(i), (iii) and (vi) are numerical expressions where as (ii), (iv) and (v), (vii) are algebraic expressions.

Do you identify the difference between them?

You can form many more expressions. As you know expressions are formed with variables and constants. In the expression $3x + 5$, x is variable and 3, 5 are constants. $3x$ is an algebraic term and 5 is a numerical term. The expression $4xy + 7$ is formed with variables x and y and constants 4 and 7.

Now $\frac{1}{3}xy$ has one term and $2xy + pq - 3$ has 3 terms in it.

So you know that terms are formed as a product of constants and one or more variables.

Terms are added or subtracted to form an **expression**.

We know that the value of the expression $3x + 5$ could be any number. If $x = 2$ the value of the expression would be $3(2) + 5 = 6 + 5 = 11$. For different values of x , the expression $3x + 5$ holds different values.



Do This

- Find the number of terms in following algebraic expressions
 $5xy^2$, $5xy^3 - 9x$, $3xy + 4y - 8$, $9x^2 + 2x + pq + q$.
- Take different values for x and find values of $3x + 5$.

Let us consider some more algebraic expressions $5xy^2$, $5xy^3 - 9x$, $3xy + 4y - 8$ etc. It is clear that $5xy^2$ is monomial, $5xy^3 - 9x$ is binomial and $3xy + 4y - 8$ is trinomial.

The sum of all exponents of the variables in a monomial is the degree of the monomial

As you know that the degree of a monomial $5x^2y$ is '3'.

Moreover the degree of the binomial $5xy^3 - 9x$ is '4'.

Similarly, the degree of the trinomial $3xy + 4y - 8$ is '2'.

The highest degree among the degrees of the different terms of an algebraic expression is called the degree of that algebraic expression.

Expressions that contain exactly one, two and three terms are called **monomials**, **binomials** and **trinomials** respectively. In general, any expression containing one or more terms with non-zero coefficients is called a **multinomial**.

11.1 Like and unlike terms

Observe the following terms.

$$2x, 3x^2, 4x, -5x, 7x^3$$

Among these $2x$, $4x$ and $-5x$ have same variable x with same exponent. These are called like terms. Like terms may not have same numerical coefficients. Why $8p$ and $8p^2$ are not like terms?



Do This

- Find the like terms in the following $ax^2y, 2x, 5y^2, -9x^2, -6x, 7xy, 18y^2$.
- Write 3 like terms for $5pq^2$

11.2 Addition and subtraction of algebraic expressions

Example 1: Add $5x^2 + 3xy + 2y^2$ and $2y^2 - xy + 4x^2$

Solution: Write the expression one under another so that like terms align in columns. Then add

$$\begin{array}{r} 5x^2 + 3xy + 2y^2 \\ + 4x^2 - xy + 2y^2 \\ \hline 9x^2 + 2xy + 4y^2 \end{array}$$



Think, Discuss and Write

- Sheela says the sum of $2pq$ and $4pq$ is $8p^2q^2$. Is she right? Give your explanation.
- Rehman added $4x$ and $7y$ and got $11xy$. Do you agree with Rehman?

Example 2: Subtract $2xy + 9x^2$ from $12xy + 4x^2 - 3y^2$

Solution: Write the expressions being subtracted (subtrahend) below the expression from which it is being subtracted (minuend) aligning like terms in columns.

$$\begin{array}{r} \text{minuend} \quad 12xy + 4x^2 - 3y^2 \\ \text{subtrahend} \quad 2xy + 9x^2 \\ \hline (-) \quad (-) \\ \hline 10xy - 5x^2 - 3y^2 \end{array}$$

Change the signs of each term in the expression being subtracted, then add.

[**Note:** Subtraction of a number is the same as addition of its additive inverse. Thus subtracting -3 is the same as adding $+3$. Similarly subtracting $9x^2$ is the same as adding $-9x^2$, subtracting $-3xy$ is same as adding $+3xy$].



Do This

1. If $A = 2y^2 + 3x - x^2$, $B = 3x^2 - y^2$ and $C = 5x^2 - 3xy$ then find
 (i) $A+B$ (ii) $A-B$ (iii) $B+C$ (iv) $B-C$ (v) $A+B+C$ (vi) $A+B-C$

11.3 Multiplication of Algebraic Expressions

Introduction: (i) Look at the following patterns of dots.

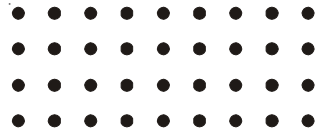
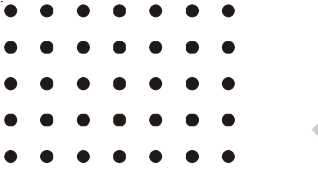
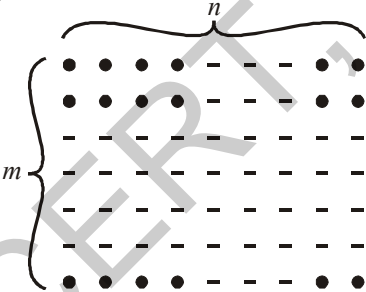
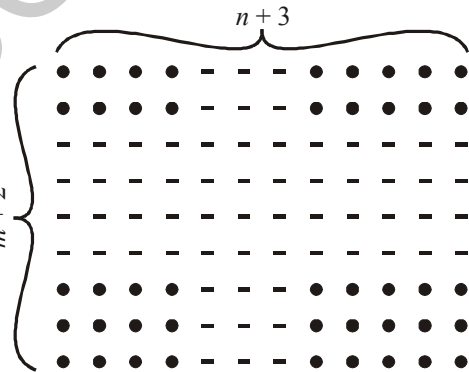
Pattern of dots	Total number of dots
	Row \times Column 4×9
	5×7
	$m \times n$
	$(m + 2) \times (n + 3)$

To find the number of dots we have to multiply the number of rows by the number of columns.

Here the number of rows is increased by 2, i.e. $m+2$ and number of columns increased by 3, i.e. $n+3$

- (ii) Can you now think of similar situations in which two algebraic expressions have to be multiplied?

We can think of area of a rectangle. The area of a rectangle is $l \times b$, where l is the length, and b is breadth. If the length of the rectangle is increased by 5 units, i.e., $(l + 5)$ units and breadth is decreased by 3 units, i.e., $(b - 3)$ units, then the area of the new rectangle will be $(l + 5) \times (b - 3)$ sq. units.

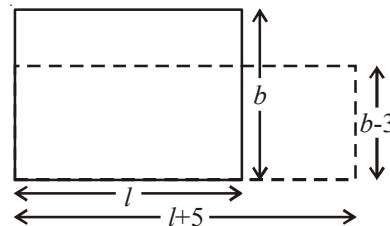

To find the area of a rectangle. We have to multiply algebraic expression like $l \times b$ and extended as $(l+5) \times (b-3)$.

- (iii) Can you think about volume of a cuboid in the form of algebraic expression? (The volume of a rectangular box is given by the product of its length, breadth and height).

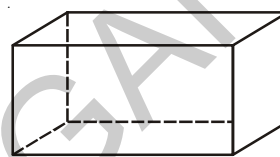

- (iv) When we buy things, we have to carry out multiplication. For example, if price of bananas per dozen is ₹ p

and bananas needed for the school picnic are z dozens,

$$\text{then we have to pay} = ₹ p \times z$$

Suppose, the price per dozen was less by ₹ 2 and the bananas needed were less by 4 dozens.

The price of bananas per dozen = ₹ $(p - 2)$ and

Bananas needed = $(z - 4)$ dozens,

Therefore, we would have to pay = ₹ $(p - 2) \times (z - 4)$



Try These

Write an algebraic expression using speed and time to calculate the distance, simple interest to be paid, using principal, time, and the rate of simple interest.

Can you think of two more such situations, where we can express in algebraic expressions?

In all the above examples, we have to carry out multiplication of two or more quantities. If the quantities are given by algebraic expressions, we need to find their product. This means that we should know how to obtain this product. Let us do this systematically. To begin with we shall look at the multiplication of two monomials.

11.4 Multiplying a monomial by a monomial

11.4.1 Multiplying two monomials

We know that

$$4 \times x = x + x + x + x = 4x$$

and $4 \times (3x) = 3x + 3x + 3x + 3x = 12x$

Now, observe the following products.

(i) $x \times 3y = x \times 3 \times y = 3 \times x \times y = 3xy$

(ii) $5x \times 3y = 5 \times x \times 3 \times y = 5 \times 3 \times x \times y = 15xy$

(iii) $5x \times (-3y) = 5 \times x \times (-3) \times y$
 $= 5 \times (-3) \times x \times y = -15xy$

(iv) $5x \times 4x^2 = (5 \times 4) \times (x \times x^2)$
 $= 20 \times x^3 = 20x^3$

(v) $5x \times (-4xyz) = (5 \times -4) \times (x \times xyz)$
 $= -20 \times (x \times x \times yz) = -20x^2yz$

For finding the product of algebraic terms, we use the rules of exponents, where the exponents having the same base are added.

Observe the following and fill the blanks.

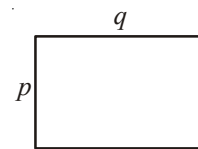
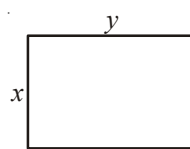
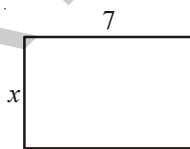
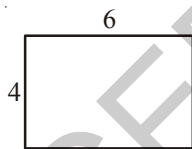

Area = $4 \times 6 = 24$ units Area = $x \times 7 = \dots$ Area = $x \times y = \dots$ Area = $\dots \times \dots = \dots$

Observe the following products:-

1. $7x \times 5y = (7 \times 5) \times (x \times y) = 35xy$

2. $3x \times (-2y) = \{3 \times (-2)\} \times (x \times y) = -6xy$

3. $(-4x) \times (-6y) = (-4) \times (-6) \times (x \times y) = 24xy$

4. $3x \times 5x^2 = (3 \times 5) \times (x \times x^2) = 15x^3$

5. $(-2x^2) \times (-4x^2) = (-2) \times (-4) \times x^2 \times x^2 = 8x^4$

- Note:** (i) Product of two positive integers is a positive integer.
(ii) Product of two negative integers is a positive integer.
(iii) Product of a positive and a negative integers is a negative integer.



Do This

1. Complete the table.

1 st Monomial	2 nd Monomial	Product of two monomials
$2x$	$-3y$	$2x \times (-3y) = -6xy$
$-4y^2$	$-2y$
$3abc$	$5bcd$
mn	$-4m$
$-3mq$	$-3nq$

2. Check whether you always get a monomial when two monomials are multiplied.

11.4.2 Multiplying three or more monomials

Observe the following examples:-

Example 3: Find the product of $5x$, $6y$ and $7z$

Solution:

Method I

$$\begin{aligned} 5x \times 6y \times 7z &= (5x \times 6y) \times 7z \\ &= 30xy \times 7z \\ &= 210xyz \end{aligned}$$

Method II

$$\begin{aligned} 5x \times 6y \times 7z &= 5 \times x \times 6 \times y \times 7 \times z \\ &= 5 \times 6 \times 7 \times x \times y \times z \\ &= 210xyz \quad (\text{first multiply coefficients} \\ &\quad \text{then variables}) \end{aligned}$$

Example 4: Find $3x^2y \times 4xy^2 \times 7x^3y^3$

Solution:

$$\begin{aligned} &3 \times 4 \times 7 \times (x^2y) \times (xy^2) \times (x^3y^3) \\ &= 84 \times x^2 \times y \times x \times y^2 \times x^3 \times y^3 \\ &= 84 \times (x^2 \times x \times x^3) \times (y \times y^2 \times y^3) \\ &= 84 \times x^6 \times y^6 = 84x^6y^6. \end{aligned}$$

Example 5: Find the product of $3x$, $-4xy$, $2x^2$, $3y^2$, $5x^3y^2$

Solution:

$$\begin{aligned} &3x \times (-4xy) \times 2x^2 \times 3y^2 \times 5x^3y^2 \\ &= [3 \times (-4) \times 2 \times 3 \times 5] \times (x \times x \times x^2 \times x^3) \times (y \times y^2 \times y^2) \\ &= -360x^7y^5. \end{aligned}$$

Have you observed that the product of any number of monomials is a monomial?



Exercise - 11.1

- Find the product of the following pairs of monomials.
 (i) $6, 7k$ (ii) $-3l, -2m$ (iii) $-5t^2, -3t^2$ (iv) $6n, 3m$ (v) $-5p^2, -2p$
- Complete the table of the products.

X	$5x$	$-2y^2$	$3x^2$	$6xy$	$3y^2$	$-3xy^2$	$4xy^2$	x^2y^2
$3x$	$15x^2$
$4y$
$-2x^2$	$-10x^3$	$4x^2y^2$
$6xy$
$2y^2$
$3x^2y$
$2xy^2$
$5x^2y^2$

- Find the volumes of rectangular boxes with given length, breadth and height in the following table.

S.No.	Length	Breadth	Height	Volume ($v = l \times b \times h$)
(i)	$3x$	$4x^2$	5	$v = 3x \times 4x^2 \times 5 = 60x^3$
(ii)	$3a^2$	4	$5c$	$v = \dots\dots\dots$
(iii)	$3m$	$4n$	$2m^2$	$v = \dots\dots\dots$
(iv)	$6kl$	$3l^2$	$2k^2$	$v = \dots\dots\dots$
(v)	$3pr$	$2qr$	$4pq$	$v = \dots\dots\dots$

- Find the product of the following monomials
 (i) xy, x^2y, xy, x (ii) a, b, ab, a^3b, ab^3 (iii) kl, lm, km, klm
 (iv) pq, pqr, r (v) $-3a, 4ab, -6c, d$
- If $A = xy, B = yz$ and $C = zx$, then $ABC = \dots\dots\dots$
- If $P = 4x^2, T = 5x$ and $R = 5y$, then $\frac{PTR}{100} = \dots\dots\dots$
- Write some monomials of your own and find their products.

11.5 Multiplying a binomial or trinomial by a monomial

11.5.1 Multiplying a binomial by a monomial

Multiplying a monomial $5x$ and a binomial $6y+3$

The process involved in the multiplication is:

Step	Instruction	Procedure
1.	Write the product of monomial and binomial using multiplication symbol	$5x \times (6y+3)$
2.	Use distributive law: Multiply the monomial by the first term of the binomial then multiply the monomial by the second term of the binomial and add their products.	$(5x \times 6y) + (5x \times 3)$
3.	Simplify the terms	$30xy + 15x$

Hence, the product of $5x$ and $6y+3$

$$\begin{aligned}5x(6y + 3) &= 5x \times (6y + 3) \\ &= (5x \times 6y) + (5x \times 3) \\ &= 30xy + 15x\end{aligned}$$

Example6: Find the product of $(-4xy)(2x - y)$

Solution:

$$\begin{aligned}(-4xy)(2x - y) &= (-4xy) \times (2x - y) \\ &= (-4xy) \times 2x + (-4xy) \times (-y) \\ &= -8x^2y + 4xy^2\end{aligned}$$

Example7: Find the product of $(3m - 2n^2)(-7mn)$

Solution:

$$\begin{aligned}(3m - 2n^2)(-7mn) &= (3m - 2n^2) \times (-7mn) \\ &= (-7mn) \times (3m - 2n^2) \\ &= ((-7mn) \times 3m) - ((-7mn) \times 2n^2) \\ &= -21m^2n + 14mn^3\end{aligned}$$

\therefore Commutative law

\therefore Distributive law



Do This

- Find the product: (i) $3x(4ax + 8by)$ (ii) $4a^2b(a-3b)$ (iii) $(p + 3q^2)pq$ (iv) $(m^3 + n^3)5mn^2$
- Find the number of maximum terms in the product of a monomial and a binomial?

11.5.2 Multiplying a trinomial by a monomial

How many maximum terms are there in the product of a monomial and a trinomial?

Consider a monomial $2x$ and a trinomial $(3x + 4y - 6)$

Their product = $2x \times (3x + 4y - 6)$

$$= (2x \times 3x) + (2x \times 4y) + (2x \times (-6)) \text{ (by using distributive law)}$$

$$= 6x^2 + 8xy - 12x$$



Exercise - 11.2

- Complete the table.

S.No.	First Expression	Second Expression	Product
1	$5q$	$p+q-2r$	$5q(p+q-2r)=5pq+5q^2-10qr$
2	$kl+lm+mn$	$3k$
3	ab^2	$a+b^2+c^3$
4	$x-2y+3z$	xyz
5	$a^2bc+b^2cd-abd^2$	$a^2b^2c^2$

- Simplify: $4y(3y+4)$
- Simplify $x(2x^2-7x+3)$ and find the values of it for (i) $x = 1$ and (ii) $x = 0$
- Add the product: $a(a-b)$, $b(b-c)$, $c(c-a)$
- Add the product: $x(x+y-r)$, $y(x-y+r)$, $z(x-y-z)$
- Subtract the product of $2x(5x-y)$ from product of $3x(x+2y)$
- Subtract $3k(5k-l+3m)$ from $6k(2k+3l-2m)$
- Simplify: $a^2(a-b+c)+b^2(a+b-c)-c^2(a-b-c)$

11.6 Multiplying a binomial by a binomial or trinomial

11.6.1 Multiplying a binomial by a binomial

Consider two binomials as $5x+6y$ and $3x - 2y$

Now, let us find the product of two binomials $5x+6y$ and $3x - 2y$

The procedure of multiplication is:

Step	Instructions	Procedure
1.	Write the product of two binomials	$(5x+6y)(3x-2y)$
2.	Using distributive law multiply the first term of the first binomial by the second binomial, multiply the second term of the first binomial by the second binomial and add the products.	$5x(3x-2y)+6y(3x-2y)$ $= (5x \times 3x) - (5x \times 2y) + (6y \times 3x) - (6y \times 2y)$
3.	Simplify the terms	$(5x \times 3x) - (5x \times 2y) + (6y \times 3x) - (6y \times 2y)$ $= 15x^2 - 10xy + 18xy - 12y^2$
4.	Add like terms	$15x^2 + 8xy - 12y^2$

Hence, the product of $5x+6y$ and $3x-2y$

$$\begin{aligned}
 &= (5x + 6y)(3x - 2y) \\
 &= 5x(3x - 2y) + 6y(3x - 2y) \text{ (by using distributive law)} \\
 &= (5x \times 3x) - (5x \times 2y) + (6y \times 3x) - (6y \times 2y) \\
 &= 15x^2 - 10xy + 18xy - 12y^2 \\
 &= 15x^2 + 8xy - 12y^2
 \end{aligned}$$



Do This

- Find the product:
 - $(a - b)(2a + 4b)$
 - $(3x + 2y)(3y - 4x)$
 - $(2m - l)(2l - m)$
 - $(k + 3m)(3m - k)$
- How many number of maximum terms will be there in the product of two binomials?

11.6.2 Multiplying a binomial by a trinomial

Consider a binomial $2x + 3y$ and trinomial $3x + 4y - 5z$.

Now, let us multiply $2x + 3y$ by $3x + 4y - 5z$.

The process of the multiplication is:

Step	Instructions	Process
1.	Write the products of the binomials and trinomial using multiplicative symbol	$(2x+3y)(3x+4y-5z)$
2.	Use distributive law: Multiply the first term of the binomial by the trinomial and multiply the second term of the binomial by the trinomial and then add the products.	$2x(3x+4y-5z)+3y(3x+4y-5z)$
3.	Simplify the terms	$(2x \times 3x) + (2x \times 4y) - (2x \times 5z) +$ $(3y \times 3x) + (3y \times 4y) - (3y \times 5z)$
4.	Add like terms	$6x^2 + 8xy - 10xz + 9xy + 12y^2 - 15yz$ $6x^2 + 17xy - 10xz + 12y^2 - 15yz$

Hence, the product of $(2x+3y)$ and $(3x+4y-5z)$ can be written as

$$\begin{aligned}
 &= (2x+3y)(3x+4y-5z) \\
 &= 2x(3x+4y-5z)+3y(3x+4y-5z) \quad (\text{by using distributive law}) \\
 &= (2x \times 3x) + (2x \times 4y) - (2x \times 5z) + (3y \times 3x) + (3y \times 4y) - (3y \times 5z) \\
 &= 6x^2 + 8xy - 10xz + 9xy + 12y^2 - 15yz \\
 &= 6x^2 + 17xy - 10xz + 12y^2 - 15yz
 \end{aligned}$$

How many maximum number of terms we get in the products of a binomial and a trinomial?



Exercise - 11.3

- Multiply the binomials:
 - $2a-9$ and $3a+4$
 - $x-2y$ and $2x-y$
 - $kl+lm$ and $k-l$
 - m^2-n^2 and $m+n$
- Find the product of the following:
 - $(x+y)(2x-5y+3xy)$
 - $(a-2b+3c)(ab^2-a^2b)$
 - $(mn-kl+km)(kl-lm)$
 - $(p^3+q^3)(p-5q+6r)$
- Simplify the following:
 - $(x-2y)(y-3x)+(x+y)(x-3y)-(y-3x)(4x-5y)$

(ii) $(m+n)(m^2-mn+n^2)$

(iii) $(a-2b+5c)(a-b) - (a-b-c)(2a+3c) + (6a+b)(2c-3a-5b)$

(iv) $(pq-qr+pr)(pq+qr) - (pr+pq)(p+q-r)$

4. If a, b, c are positive real numbers such that $\frac{a+b-c}{c} = \frac{a-b+c}{b} = \frac{-a+b+c}{a}$, find the value of $\frac{(a+b)(b+c)(c+a)}{abc}$.

11.7 What is an identity?

Consider the equation $a(a-2)=a^2-2a$

Verify both sides of the equation for any value of a

For $a=5$, LHS = $5(5-2) = 5 \times 3 = 15$

RHS = $5^2 - 2(5) = 25 - 10 = 15$

Hence, in the equation LHS = RHS for $a=5$.

Similarly, let us consider $a = -2$

LHS = $(-2)(-2-2) = (-2) \times (-4) = 8$

RHS = $(-2)^2 - 2(-2) = 4 + 4 = 8$

Thus, in the equation LHS = RHS for $a=-2$ also.

We can say that the equation is true for any value of a . Therefore, the equation is called an identity.

Consider an equation $a(a+1) = 6$

This equation is true only for $a = 2$ and -3 but it is not true for other values.

So, this $a(a+1) = 6$ equation is not an identity. An equation is called an identity if it is satisfied by any value that replaces its variable(s).

An equation is true for certain values of the variable in it, where as an identity is true for all its variables. Thus it is known as universally true equation. We use symbol for denoting identity is ' \equiv ' (read as identically equal to)

11.8 Some important Identities

We often use some of the identities, which are very useful in solving problems. Those identities used in multiplication are also called as special products. Among them, we shall study three important identities, which are products of a binomial.

Consider $(a + b)^2$

Now,

$$\begin{aligned}(a + b)^2 &= (a + b)(a + b) \\ &= a(a + b) + b(a + b) \\ &= a^2 + ab + ba + b^2 = a^2 + ab + ab + b^2 && \text{(since } ab = ba\text{)} \\ &= a^2 + 2ab + b^2\end{aligned}$$

$$\text{Thus } (a + b)^2 = a^2 + 2ab + b^2 \quad \text{(I)}$$

Now, take $a=2$, $b=3$, we obtain $(\text{LHS}) = (a + b)^2 = (2+3)^2 = 5^2 = 25$

$$(\text{RHS}) = a^2 + 2ab + b^2 = 2^2 + 2(2)(3) + 3^2 = 4 + 12 + 9 = 25$$

Observe the LHS and RHS. The values of the expressions on the LHS and RHS are equal.

Verify Identity-I for some positive integer, negative integer and fraction by (taking some values for a,b)



Do This

Taking a, b, c as positive integers, verify the following whether they are identities or not?

(i) $(a - b)^2 \equiv a^2 - 2ab + b^2$

(ii) $(a + b)(a - b) \equiv a^2 - b^2$

(iii) $(a + b + c)^2 \equiv a^2 + b^2 + c^2 + 2ab + 2bc + 2ca$

Consider one more identity, $(x + a)(x + b) \equiv x^2 + (a + b)x + ab$,

$$(x + a)(x + b) = x(x + b) + a(x + b)$$

$$= x^2 + bx + ax + ab$$

$$= x^2 + (a + b)x + ab$$



Do This

Now take $x = 2$, $a = 1$ and $b = 3$, verify the above identity.

- What do you observe? Is $\text{LHS} = \text{RHS}$?
- Take different values for x, a and b for verification of the above identity.
- Is it always $\text{LHS} = \text{RHS}$ for all values of a and b ?

- Consider $(x + p)(x + q) = x^2 + (p + q)x + pq$
 - Put q instead of ' p ' what do you observe?
 - Put p instead of ' q ' what do you observe?
 - What identities did you observe in your results?

11.9 Application of Identities

Example 8: Expand $(3x + 4y)^2$

Solution: $(3x + 4y)^2$ is the product of two binomial expressions, which have the same terms $(3x + 4y)$ and $(3x + 4y)$. It can be expanded by the method of multiplying a binomial by a binomial. Compare the identities with this product. In this product $a = 3x$ and $b = 4y$. We can get the result of this product by substituting $3x$ and $4y$ terms in the place of a and b respectively in the first identity $(a+b)^2 = a^2 + 2ab + b^2$

$$\begin{aligned} \text{Hence, } (3x + 4y)^2 &= (3x)^2 + 2(3x)(4y) + (4y)^2 \\ &= 9x^2 + 24xy + 16y^2 \end{aligned}$$

Where $a = 3x$ and $b = 4y$
identity $(a + b)^2 \equiv a^2 + 2ab + b^2$

Example 9: Find 204^2 using suitable identify

$$\begin{aligned} 204^2 &= (200 + 4)^2 \\ &= (200)^2 + 2(200)(4) + 4^2 \\ &= 40000 + 1600 + 16 \\ &= 41616 \end{aligned}$$

Where $a = 200$ and $b = 4$
identity $(a + b)^2 \equiv a^2 + 2ab + b^2$



Do This

Expand: (i) $(5m + 7n)^2$ (ii) $(6kl + 7mn)^2$ (iii) $(5a^2 + 6b^2)^2$ (iv) 302^2
(v) 807^2 (vi) 704^2

(vii) Verify the identity : $(a - b)^2 = a^2 - 2ab + b^2$, where $a = 3m$ and $b = 5n$

Example 10: Expand $(3m - 5n)^2$

Solution:
$$\begin{aligned} (3m - 5n)^2 &= (3m)^2 - 2(3m)(5n) + (5n)^2 \\ &= 9m^2 - 30mn + 25n^2 \end{aligned}$$

Where $a = 3m$ and $b = 5n$
identity: $(a - b)^2 \equiv a^2 - 2ab + b^2$

Example11: Find 196^2

Solution: $196^2 = (200 - 4)^2$
 $= 200^2 - 2(200)(4) + 4^2$
 $= 40000 - 1600 + 16$
 $= 38416$

Where $a = 200$ and $b = 4$
identity: $(a - b)^2 \equiv a^2 - 2ab + b^2$



Do This

Find: (i) $(9m - 2n)^2$ (ii) $(6pq - 7rs)^2$ (iii) $(5x^2 - 6y^2)^2$
(iv) 292^2 (v) 897^2 (vi) 794^2

Example12: Find $(4x + 5y)(4x - 5y)$

Solution: $(4x + 5y)(4x - 5y) = (4x)^2 - (5y)^2$
 $= 16x^2 - 25y^2$

Where $a = 4x$ and $b = 5y$
identity: $(a + b)(a - b) \equiv a^2 - b^2$

Example13: Find 407×393

Solution: $407 \times 393 = (400 + 7)(400 - 7)$
 $= 400^2 - 7^2$
 $= 160000 - 49$
 $= 159951$

Where $a = 400$ and $b = 7$ in the
identity: $(a + b)(a - b) \equiv a^2 - b^2$

Example14: Find $987^2 - 13^2$

Solution: $987^2 - 13^2 = (987 + 13)(987 - 13)$
 $= 1000 \times 974 = 974000$

Where $a = 987$ and $b = 13$ in the
identity: $a^2 - b^2 \equiv (a + b)(a - b)$



Do These

Find the values of the following.

(i) $(6m + 7n)(6m - 7n)$ (ii) $(5a + 10b)(5a - 10b)$
(iii) $(3x^2 + 4y^2)(3x^2 - 4y^2)$ (iv) 106×94 (v) 592×608 (vi) $92^2 - 8^2$
(vii) $984^2 - 16^2$

Example15: Find 302×308

Solution: $302 \times 308 = (300 + 2)(300 + 8)$
 $= 300^2 + (2 + 8)(300) + (2)(8)$
 $= 90000 + (10 \times 300) + 16$
 $= 90000 + 3000 + 16 = 93016$

Where $x = 300$, $a = 2$ and $b = 8$ in the
identity: $(x + a)(x + b) \equiv x^2 + (a + b)x + ab$

Example16: Find 93×104

Solution: $93 \times 104 = (100 + (-7))(100 + 4)$

$$\begin{aligned} 93 \times 104 &= (100 - 7)(100 + 4) \\ &= 100^2 + (-7 + 4)(100) + (-7)(4) \\ &= 10000 + (-3)(100) + (-28) \\ &= 10000 - 300 - 28 \\ &= 10000 - 328 = 9672 \end{aligned}$$

Where $x = 100$, $a = -7$ and $b = 4$ in the identity: $(x + a)(x + b) \equiv x^2 + (a+b)x + ab$

Do you notice? Finding the products by using identities is much easier than finding by direct multiplication.



Exercise - 11.4

1. Select a suitable identity and find the following products

(i) $(3k + 4l)(3k + 4l)$ (ii) $(ax^2 + by^2)(ax^2 + by^2)$

(iii) $(7d - 9e)(7d - 9e)$ (iv) $(m^2 - n^2)(m^2 + n^2)$

(v) $(3t + 9s)(3t - 9s)$ (vi) $(kl - mn)(kl + mn)$

(vii) $(6x + 5)(6x + 6)$ (viii) $(2b - a)(2b + c)$

2. Evaluate the following by using suitable identities:

(i) 304^2 (ii) 509^2 (iii) 992^2 (iv) 799^2

(v) 304×296 (vi) 83×77 (vii) 109×108 (viii) 204×206

11.10 Geometrical Verification of the identities

11.10.1 Geometrical Verification of the identity $(a + b)^2 \equiv a^2 + 2ab + b^2$

Observe the following square:

Consider a square with side $(a + b)$

Its area = square of the side = $(\text{side})^2 = (a + b)^2$

Divide the square into four regions as shown in figure.

It consists of two squares with sides 'a' and 'b' respectively and two rectangles with length and breadth as 'a' and 'b' respectively.

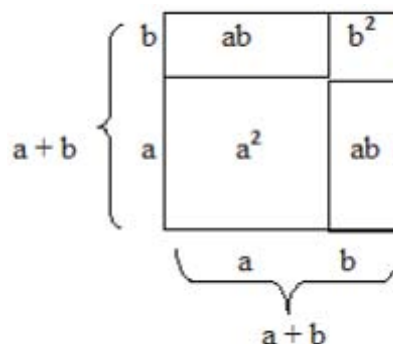

Clearly, the area of the given square is equal to sum of the area of four regions.

Area of the given square

$$\begin{aligned}
 &= \text{Area of the square with side } a + \text{area of rectangle with sides } a \text{ and } b + \text{area of} \\
 &\quad \text{rectangle with sides } b \text{ and } a + \text{area of square with side } b \\
 &= a^2 + ab + ba + b^2 \\
 &= a^2 + 2ab + b^2
 \end{aligned}$$

Therefore, $(a + b)^2 \equiv a^2 + 2ab + b^2$

Example17: Verify the identity $(a + b)^2 \equiv a^2 + 2ab + b^2$ geometrically by taking $a = 3$ and $b = 2$

Solution: $(a + b)^2 \equiv a^2 + 2ab + b^2$

Draw a square with the side $a + b$, i.e., $3 + 2$

L.H.S. Area of whole square
 $= (3 + 2)^2 = 5^2 = 25$

R.H.S. = Area of square with side 3 units +
 Area of square with side 2 units +
 Area of rectangle with sides 3 units, 2 units +
 Area of rectangle with sides 2 units, 3 units
 $= 3^2 + 2^2 + 3 \times 2 + 3 \times 2$
 $= 9 + 4 + 6 + 6 = 25$

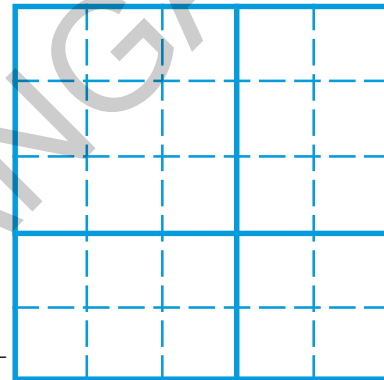

L.H.S. = R.H.S.
 \therefore Hence the identity is verified.

11.10.2 Geometrical Verification of the identity $(a - b)^2 \equiv a^2 - 2ab + b^2$

Consider a square with side a .

- The area of the square = side \times side = a^2
- The square is divided into four regions.
- It consists of two squares with sides $a - b$ and b respectively and two rectangles with length and breadth as ' $a - b$ ' and ' b ' respectively.

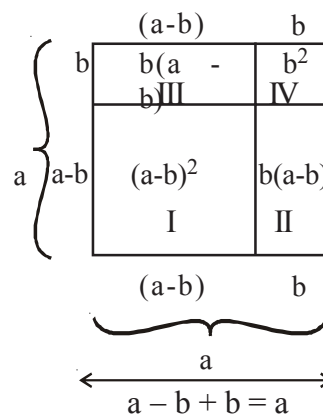

Now Area of figure I = Area of whole square with side 'a' –

Area of figure II – Area of figure III – Area of figure IV

$$\begin{aligned}(a-b)^2 &= a^2 - b(a-b) - b(a-b) - b^2 \\ &= a^2 - ab + b^2 - ab + b^2 - b^2 \\ &= a^2 - 2ab + b^2\end{aligned}$$

11.10.3 Geometrical Verification of the identity $(a + b)(a - b) \equiv a^2 - b^2$

$a^2 - b^2$ = (Area of square where the side is 'a') – (Area of square where the side is 'b')

Observe the following square:

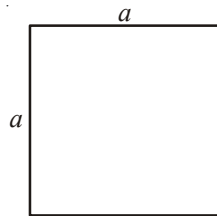

Remove square with a length of 'b' units from one corner of this square, where $b < a$

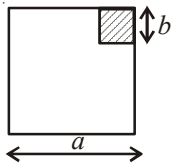

We get

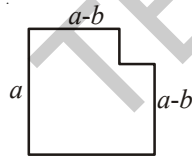

It consists of two parts

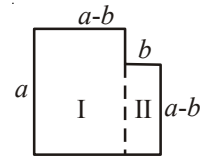

$$\begin{aligned}\text{So } a^2 - b^2 &= \text{Area of figure I} + \text{area of figure II} \\ &= a(a-b) + b(a-b) \\ &= (a-b)(a+b)\end{aligned}$$

$$\text{Thus } a^2 - b^2 \equiv (a-b)(a+b)$$



Exercise - 11.5

- Verify the identity $(a + b)^2 \equiv a^2 + 2ab + b^2$ geometrically by taking
 - $a = 2$ units, $b = 4$ units
 - $a = 3$ units, $b = 1$ unit
 - $a = 5$ units, $b = 2$ unit

2. Verify the identity $(a - b)^2 \equiv a^2 - 2ab + b^2$ geometrically by taking
 - (i) $a = 3$ units, $b = 1$ unit
 - (ii) $a = 5$ units, $b = 2$ units
3. Verify the identity $(a + b)(a - b) \equiv a^2 - b^2$ geometrically by taking
 - (i) $a = 3$ units, $b = 2$ units
 - (ii) $a = 2$ units, $b = 1$ unit



What we have discussed

1. There are number of situations in which we need to multiply algebraic expressions.
2. A monomial multiplied by a monomial always gives a monomial.
3. In carrying out the multiplication of an algebraic expression with another algebraic expression (monomial / binomial / trianomial etc.) we multiply term by term i.e. every term of the expression is multiplied by every term in the other expression.
4. An **identity** is an equation, which is true for all values of the variables in the equation. On the other hand, an equation is true only for certain values of its variables. An equation is not an identity.
5. The following are identities:
 - I. $(a + b)^2 \equiv a^2 + 2ab + b^2$
 - II. $(a - b)^2 \equiv a^2 - 2ab + b^2$
 - III. $(a + b)(a - b) \equiv a^2 - b^2$
 - IV. $(x + a)(x + b) \equiv x^2 + (a + b)x + ab$
6. The above four identities are useful in carrying out squares and products of algebraic expressions. They also allow easy alternative methods to calculate products of numbers and so on.





12.0 Introduction

Let us consider the number 42. Try to write '42' as product of any two numbers.

$$\begin{aligned} 42 &= 1 \times 42 \\ &= 2 \times 21 \\ &= 3 \times 14 \\ &= 6 \times 7 \end{aligned}$$

Thus 1, 2, 3, 6, 7, 14, 21 and 42 are the factors of 42. Among the above factors, which are prime numbers?

Do you express 42 as product of prime numbers? Try.

Rafi did like this

$$\begin{aligned} 42 &= 2 \times 21 \\ &= 2 \times 3 \times 7 \end{aligned}$$

Sirisha did like this

$$\begin{aligned} 42 &= 3 \times 14 \\ &= 2 \times 3 \times 7 \end{aligned}$$

Akbar did like this

$$\begin{aligned} 42 &= 6 \times 7 \\ &= 2 \times 3 \times 7 \end{aligned}$$

What do you observe? We observe that $2 \times 3 \times 7$ is the product of prime factors in every case.

Now consider another number say '70'

The factors of 70 are 1, 2, 5, 7, 10, 14, 35 and 70

70 can be written as $2 \times 5 \times 7$ as the product of prime factors.

Expressing as a product of prime factors is called the prime factorisation method.

$$\begin{aligned} 70 &= 1 \times 70 \\ &= 2 \times 35 \\ &= 5 \times 14 \\ &= 7 \times 10 \end{aligned}$$



Do This

Express the given numbers in the form of product of primes

- (i) 48 (ii) 72 (ii) 96

As we did for numbers we can also express algebraic expressions as the product of their factors. We shall learn about factorisation of various algebraic expressions in this chapter.

12.1 Factors of algebraic expressions

Consider the following example :

$$\begin{aligned}7yz &= 7(yz) && (7 \text{ and } yz \text{ are the factors}) \\ &= 7y(z) && (7y \text{ and } z \text{ are the factors}) \\ &= 7z(y) && (7z \text{ and } y \text{ are the factors}) \\ &= 7 \times y \times z && (7, y \text{ and } z \text{ are the factors})\end{aligned}$$

Among the above factors $7, y, z$ are irreducible factors. The phrase '*irreducible*' is used in the place of '*prime*' in algebraic expressions. Thus we say that $7 \times y \times z$ is the irreducible form of $7yz$. Note that $7 \times (yz)$ or $7y(z)$ or $7z(y)$ are not an irreducible form.

'1' is the factor of $7yz$, since $7yz = 1 \times 7 \times y \times z$. In fact '1' is the factor of every term. But unless required, '1' need not be shown separately.

Let us now consider the expression $7y(z+3)$.

It can be written as $7y(z+3) = 7 \times y \times (z+3)$. Here $7, y, (z+3)$ are the irreducible factors.

Similarly $5x(y+2)(z+3) = 5 \times x \times (y+2) \times (z+3)$ Here $5, x, (y+2), (z+3)$ are irreducible factors.



Do This

1. Find the factors of following algebraic expressions:

(i) $8x^2yz$ (ii) $2xy(x+y)$ (iii) $3x+y^3z$

12.2 Need of factorisation

When an algebraic expression is factorised, it is written as the product of its factors. These factors may be numerals, algebraic variables or terms of algebraic expressions.

Consider the algebraic expression $23a + 23b + 23c$.

This can be written as $23(a + b + c)$, here the irreducible factors are 23 and $(a + b + c)$. 23 is a numerical factor and $(a + b + c)$ is algebraic factor.

Let us, discuss about the methods to find factors of an algebraic expression.

Consider the algebraic expressions (i) $x^2y + y^2x + xy$ (ii) $(4x^2 - 1) \div (2x - 1)$.

The first expression $x^2y + y^2x + xy = xy(x + y + 1)$ thus the above algebraic expression is written in simpler form.

The second expression $(4x^2 - 1) \div (2x - 1)$

$$\begin{aligned}\frac{4x^2 - 1}{2x - 1} &= \frac{(2x)^2 - (1)^2}{2x - 1} \\ &= \frac{(2x + 1)(2x - 1)}{(2x - 1)} \\ &= (2x + 1)\end{aligned}$$

From above illustrations it is noticed that the factorisation has helped to write the algebraic expression in simpler form and it also helps in simplifying the algebraic expression

Let us now discuss of factorisation of some algebraic expressions.

12.3 Method of common factors

Let us factorise $3x + 12$

On writing each term as the product of irreducible factors we get :

$$3x + 12 = (3 \times x) + (2 \times 2 \times 3)$$

What are the common factors of both the terms ?

By taking the common factor 3, we get

$$3 \times [x + (2 \times 2)] = 3 \times (x + 4) = 3(x + 4)$$

Thus the expression $3x + 12$ is the same as $3(x + 4)$.

Now we say that 3 and $(x + 4)$ are the factors of $3x + 12$. Also note that these factors are irreducible.

Now let us factorise another expression $6ab + 12b$

$$\begin{aligned}6ab + 12b &= (2 \times 3 \times a \times b) + (2 \times 2 \times 3 \times b) \\ &= 2 \times 3 \times b \times (a + 2) = 6b(a + 2)\end{aligned}$$

$6b$ is the HCF of $6ab$ and $12b$

$$\therefore 6ab + 12b = 6b(a + 2)$$

Example 1: Factorize (i) $6xy + 9y^2$ (ii) $25a^2b + 35ab^2$

Solution: (i) $6xy + 9y^2$

We have $6xy = 2 \times 3 \times x \times y$ and $9y^2 = 3 \times 3 \times y \times y$

3 and ' y ' are the common factors of the two terms

$$\begin{aligned} \text{Hence, } 6xy + 9y^2 &= (2 \times \underline{3} \times x \times y) + (3 \times \underline{3} \times y \times y) \\ &= \underline{3} \times \underline{y} \times [(2 \times x) + (3 \times y)] \end{aligned}$$

$$\therefore 6xy + 9y^2 = 3y(2x + 3y)$$

$$\begin{aligned} \text{(ii) } 25a^2b + 35ab^2 &= (5 \times \underline{5} \times a \times a \times b) + (\underline{5} \times 7 \times a \times b \times b) \\ &= \underline{5} \times a \times b \times [(5 \times a) + (7 \times b)] \\ &= 5ab(5a + 7b) \end{aligned}$$

$$\therefore 25a^2b + 35ab^2 = 5ab(5a + 7b)$$

Example 2: Factorise $3x^2 + 6x^2y + 9xy^2$

Solution: $3x^2 + 6x^2y + 9xy^2 = (\underline{3} \times x \times x) + (2 \times \underline{3} \times x \times x \times y) + (3 \times \underline{3} \times x \times y \times y)$

$$\begin{aligned} &= \underline{3} \times x [x + (2 \times x \times y) + (3 \times y \times y)] \\ &= 3x(x + 2xy + 3y^2) \quad (\text{taking } 3 \times x \text{ as common factor}) \end{aligned}$$

$$\therefore 3x^2 + 6x^2y + 9xy^2 = 3x(x + 2xy + 3y^2)$$



Do This

Factorise (i) $9a^2 - 6a$ (ii) $15a^3b - 35ab^3$ (iii) $7lm - 2lmn$

12.4 Factorisation by grouping the terms

Observe the expression $ax + bx + ay + by$. You will find that there is no single common factor to all the terms. But the first two terms have the common factor 'x' and the last two terms have the common factor 'y'. Let us see how we can factorise such an expression.

On grouping the terms we get $(ax + bx) + (ay + by)$
(By taking out common factors from the groups)

$$(ax + bx) + (ay + by) = x(a + b) + y(a + b) \quad (\text{By taking out common factors from each group})$$

$$= (a + b)(x + y)$$

The expression $ax + bx + ay + by$ is now expressed as the product of its factors. The factors are $(a + b)$ and $(x + y)$, which are irreducible.

The above expression can be factorised by another way of grouping, as follows :

$$\begin{aligned} ax + ay + bx + by &= (ax + ay) + (bx + by) \\ &= a(x + y) + b(x + y) \\ &= (x + y)(a + b) \end{aligned}$$



Do This

Factorise (i) $5xy + 5x + 4y + 4$ (ii) $3ab + 3a + 2b + 2$

Example 3: Factorise $6ab - b^2 - 2bc + 12ac$

Solution: Step 1: Check whether there are any common factors for all terms.

Step 2: On regrouping the first two terms we have

$$6ab - b^2 = b(6a - b) \quad \text{---I}$$

Note that you need to change order of the last two terms in the expression as $12ac - 2bc$.

$$\text{Thus } 12ac - 2bc = 2c(6a - b) \quad \text{---II}$$

Step 3: Combining I and II together

$$\begin{aligned} 6ab - b^2 - 2bc + 12ac &= b(6a - b) + 2c(6a - b) \\ &= (6a - b)(b + 2c) \end{aligned}$$

By taking out common factor $(6a - b)$

Hence the factors of $6ab - b^2 - 2bc + 12ac$ are $(6a - b)$ and $(b + 2c)$



Exercise - 12.1

- Find the common factors of the given terms in each.
 - $8x, 24$
 - $3a, 21ab$
 - $7xy, 35x^2y^3$
 - $4m^2, 6m^2, 8m^3$
 - $15p, 20qr, 25rp$
 - $4x^2, 6xy, 8y^2x$
 - $12x^2y, 18xy^2$
- Factorise the following expressions
 - $5x^2 - 25xy$
 - $9a^2 - 6ax$
 - $7p^2 + 49pq$
 - $36a^2b - 60a^2bc$
 - $3a^2bc + 6ab^2c + 9abc^2$
 - $4p^2 + 5pq - 6pq^2$
 - $ut + at^2$
- Factorise the following :
 - $3ax - 6xy + 8by - 4ab$
 - $x^3 + 2x^2 + 5x + 10$
 - $m^2 - mn + 4m - 4n$
 - $a^3 - a^2b^2 - ab + b^3$
 - $p^2q - pr^2 - pq + r^2$

12.5 Factorisation using identities

We know that $(a + b)^2 \equiv a^2 + 2ab + b^2$
 $(a - b)^2 \equiv a^2 - 2ab + b^2$
 $(a + b)(a - b) \equiv a^2 - b^2$ are some algebraic identities.

We can use these identities for factorisation, if the given expression is in the form of RHS (Right Hand Side) of the particular identity. Let us see some examples.

Example 4: Factorise $x^2 + 10x + 25$

Solution: The given expression contains three terms and the first and third terms are perfect squares. That is x^2 and $25 (5^2)$. Also the middle term contains the positive sign. This suggests that it can be written in the form of $a^2 + 2ab + b^2$,

$$\text{so } x^2 + 10x + 25 = (x)^2 + 2(x)(5) + (5)^2$$

We can compare it with $a^2 + 2ab + b^2$ which in turn is equal to the LHS of the identity i.e. $(a + b)^2$. Here $a = x$ and $b = 5$

$$\text{We have } x^2 + 10x + 25 = (x + 5)^2 = (x + 5)(x + 5)$$

Example 5: Factorise $16z^2 - 48z + 36$

Solution: Taking common numerical factor from the given expression we get

$$16z^2 - 48z + 36 = (4 \times 4z^2) - (4 \times 12z) + (4 \times 9) = 4(4z^2 - 12z + 9)$$

Note that $4z^2 = (2z)^2$; $9 = (3)^2$ and $12z = 2(2z)(3)$

$$4z^2 - 12z + 9 = (2z)^2 - 2(2z)(3) + (3)^2 \text{ since } a^2 - 2ab + b^2 = (a - b)^2 \\ = (2z - 3)^2$$

$$\text{By comparison, } 16z^2 - 48z + 36 = 4(4z^2 - 12z + 9) = 4(2z - 3)^2 \\ = 4(2z - 3)(2z - 3)$$

Example 6: Factorise $25p^2 - 49q^2$

Solution: We notice that the expression is a difference of two perfect squares.

i.e., the expression is of the form $a^2 - b^2$.

Hence Identity $a^2 - b^2 = (a + b)(a - b)$ can be applied

$$25p^2 - 49q^2 = (5p)^2 - (7q)^2 \\ = (5p + 7q)(5p - 7q) [\because a^2 - b^2 = (a + b)(a - b)]$$

$$\text{Therefore, } 25p^2 - 49q^2 = (5p + 7q)(5p - 7q)$$

Example 7: Factorise $48a^2 - 243b^2$

Solution: We see that the two terms are not perfect squares. But both have '3' as common factor.

$$\begin{aligned} \text{That is } 48a^2 - 243b^2 &= 3 [16a^2 - 81b^2] \\ &= 3 [(4a)^2 - (9b)^2] \quad \text{Again } a^2 - b^2 = (a+b)(a-b) \\ &= 3 [(4a + 9b)(4a - 9b)] \\ &= 3 (4a + 9b)(4a - 9b) \end{aligned}$$

Example 8: Factorise $x^2 + 2xy + y^2 - 4z^2$

Solution: The first three terms of the expression are in the form $(x+y)^2$ and the fourth term is a perfect square.

$$\begin{aligned} \text{Hence } x^2 + 2xy + y^2 - 4z^2 &= (x+y)^2 - (2z)^2 \\ &= [(x+y) + 2z] [(x+y) - 2z] \quad \boxed{a^2 - b^2 = (a+b)(a-b)} \\ &= (x+y+2z)(x+y-2z) \end{aligned}$$

Example 9: Factorise $p^4 - 256$

Solution: $p^4 = (p^2)^2$ and $256 = (16)^2$

$$\begin{aligned} \text{Thus } p^4 - 256 &= (p^2)^2 - (16)^2 \quad \boxed{\therefore p^2 - 16 = (p+4)(p-4)} \\ &= (p^2 - 16)(p^2 + 16) \\ &= (p+4)(p-4)(p^2 + 16) \end{aligned}$$

12.6 Factors of the expression in the form of $(x+a)(x+b) = x^2 + (a+b)x + ab$

Observe the expressions $x^2 + 12x + 35$, $x^2 + 6x - 27$, $a^2 - 6a + 8$, $3y^2 + 9y + 6$... etc. These expressions can not be factorised by using earlier identities, as the constant terms are not perfect squares.

Consider $x^2 + 12x + 35$.

All these terms cannot be grouped for factorisation. Let us look for two factors of 35 whose sum is 12 so that it is in the form of identity $x^2 + (a+b)x + ab$

Consider all the possible ways of writing the constant as a product of two factors.

$$\begin{array}{ll} 35 = 1 \times 35 & 1 + 35 = 36 \\ & (-1) \times (-35) & -1 - 35 = -36 \\ \boxed{5 \times 7} & \boxed{5 + 7 = 12} \\ \boxed{(-5) \times (-7)} & \boxed{-5 - 7 = -12} \end{array}$$

Sum of which pair is equal to the coefficient of the middle terms? Obviously it is $5 + 7 = 12$

$$\begin{aligned}
 \therefore x^2 + 12x + 35 &= x^2 + (5 + 7)x + 35 \\
 &= x^2 + 5x + 7x + 35 \quad (\because 12x = 5x + 7x) \\
 &= x(x + 5) + 7(x + 5) \quad (\text{By taking out common factors}) \\
 &= (x + 5)(x + 7) \quad (\text{By taking out } (x + 5) \text{ as common factor})
 \end{aligned}$$

From the above discussion we may conclude that the expression which can be written in the form of $x^2 + (a + b)x + ab$ can be factorised as $(x + a)(x + b)$

Example 10: Factorise $m^2 - 4m - 21$

Solution: Comparing $m^2 - 4m - 21$ with the identity $x^2 + (a + b)x + ab$ we note that

$$ab = -21, \text{ and } a + b = -4. \text{ So, } (-7) + 3 = -4 \text{ and } (-7)(3) = -21$$

$$\text{Hence } m^2 - 4m - 21 = m^2 - 7m + 3m - 21$$

$$= m(m - 7) + 3(m - 7)$$

$$= (m - 7)(m + 3)$$

$$\therefore m^2 - 4m - 21 = (m - 7)(m + 3)$$

Factors of -21 and their sum	
$-1 \times 21 = -21$	$-1 + 21 = 20$
$1 \times (-21) = -21$	$1 - 21 = -20$
$-7 \times 3 = -21$	$-7 + 3 = -4$
$-3 \times 7 = -21$	$-3 + 7 = 4$

Example 11: Factorise $4x^2 + 20x - 96$

Solution: We notice that 4 is the common factor of all the terms.

$$\text{Thus } 4x^2 + 20x - 96 = 4[x^2 + 5x - 24]$$

$$x^2 + 5x - 24$$

$$= x^2 + 8x - 3x - 24$$

$$= x(x + 8) - 3(x + 8)$$

$$= (x + 8)(x - 3)$$

$$\therefore 4x^2 + 20x - 96 = 4(x + 8)(x - 3)$$

Factors of -24 and their sum	
$-1 \times 24 = -24$	$-1 + 24 = 23$
$1 \times (-24) = -24$	$1 - 24 = -23$
$-8 \times 3 = -24$	$3 - 8 = -5$
$-3 \times 8 = -24$	$-3 + 8 = 5$



Exercise - 12.2

1. Factorise the following expressions-

(i) $a^2 + 10a + 25$

(ii) $l^2 - 16l + 64$

(iii) $36x^2 + 96xy + 64y^2$

(iv) $25x^2 + 9y^2 - 30xy$

(v) $25m^2 - 40mn + 16n^2$

(vi) $81x^2 - 198xy + 121y^2$

(vii) $(x+y)^2 - 4xy$

(Hint : first expand $(x + y)^2$)

(viii) $l^4 + 4l^2m^2 + 4m^4$

2. Factorise the following

(i) $x^2 - 36$

(ii) $49x^2 - 25y^2$

(iii) $m^2 - 121$

(iv) $81 - 64x^2$

(v) $x^2y^2 - 64$

(vi) $6x^2 - 54$

(vii) $x^2 - 81$

(viii) $2x - 32x^5$

(ix) $81x^4 - 121x^2$

(x) $(p^2 - 2pq + q^2) - r^2$

(xi) $(x + y)^2 - (x - y)^2$

3. Factorise the expressions-

(i) $lx^2 + mx$

(ii) $7y^2 + 35Z^2$

(iii) $3x^4 + 6x^3y + 9x^2Z$

(iv) $x^2 - ax - bx + ab$

(v) $3ax - 6ay - 8by + 4bx$

(vi) $mn + m + n + 1$

(vii) $6ab - b^2 + 12ac - 2bc$

(viii) $p^2q - pr^2 - pq + r^2$

(ix) $x(y+z) - 5(y+z)$

4. Factorise the following

(i) $x^4 - y^4$

(ii) $a^4 - (b+c)^4$

(iii) $l^2 - (m-n)^2$

(iv) $49x^2 - \frac{16}{25}$

(v) $x^4 - 2x^2y^2 + y^4$

(vi) $4(a+b)^2 - 9(a-b)^2$

5. Factorise the following expressions

(i) $a^2 + 10a + 24$

(ii) $x^2 + 9x + 18$

(iii) $p^2 - 10p + 21$

(iv) $x^2 - 4x - 32$

12.7 Division of algebraic expressions

We know that division is the inverse operation of multiplication.

Let us consider $3x \times 5x^3 = 15x^4$

Then $15x^4 \div 5x^3 = 3x$ and $15x^4 \div 3x = 5x^3$

Similarly consider $6a(a+5) = 6a^2 + 30a$

Therefore $(6a^2 + 30a) \div 6a = a + 5$

and also $(6a^2 + 30a) \div (a+5) = 6a$.

12.8 Division of a monomial by another monomial

Consider $24x^3 \div 3x$

$$\therefore 24x^3 \div 3x$$

$$= \frac{2 \times 2 \times 2 \times 3 \times x \times x \times x}{3 \times x}$$

$$= \frac{(3 \times x)(2 \times 2 \times 2 \times x \times x)}{(3 \times x)} = 8x^2$$

Example 12: Do the following Division

(i) $70x^4 \div 14x^2$ (ii) $4x^3y^3z^3 \div 12xyz$

Solution: (i) $70x^4 \div 14x^2 = \frac{2 \times 5 \times 7 \times x \times x \times x \times x}{2 \times 7 \times x \times x}$

$$= \frac{5 \times x \times x}{1}$$

$$= 5x^2$$

(ii) $4x^3y^3z^3 \div 12xyz = \frac{4 \times x \times x \times x \times y \times y \times y \times z \times z \times z}{12 \times x \times y \times z}$

$$= \frac{1}{3}x^2y^2z^2$$

12.9 Division of an expression by a monomial

Let us consider the division of the trinomial

$6x^4 + 10x^3 + 8x^2$ by a monomial $2x^2$

$$6x^4 + 10x^3 + 8x^2 = [2 \times 3 \times x \times x \times x \times x] + [2 \times 5 \times x \times x \times x] + [2 \times 2 \times 2 \times x \times x]$$

$$= \underline{(2x^2)} (3x^2) + \underline{(2x^2)} (5x) + \underline{2x^2} (4)$$

$$= 2x^2 [3x^2 + 5x + 4]$$

$\therefore 2x^2$ is common factor

Thus $(6x^4 + 10x^3 + 8x^2) \div 2x^2$

$$= \frac{6x^4 + 10x^3 + 8x^2}{2x^2} = \frac{2x^2 (3x^2 + 5x + 4)}{2x^2}$$

$$= (3x^2 + 5x + 4)$$

Alternatively each term in the expression could be divided by the monomial (using the cancellation method)

$$(6x^4 + 10x^3 + 8x^2) \div 2x^2$$

$$= \frac{6x^4}{2x^2} + \frac{10x^3}{2x^2} + \frac{8x^2}{2x^2}$$

Here we divide each term of the expression in the numerator by the monomial in the denominator

$$= 3x^2 + 5x + 4$$

Example 13: Divide $30(a^2bc + ab^2c + abc^2)$ by $6abc$

Solution : $30(a^2bc + ab^2c + abc^2)$

$$= 2 \times 3 \times 5 [(a \times a \times b \times c) + (a \times b \times b \times c) + (a \times b \times c \times c)]$$

$$= 2 \times 3 \times 5 \times a \times b \times c (a + b + c)$$

Thus $30(a^2bc + ab^2c + abc^2) \div 6abc$

$$= \frac{2 \times 3 \times 5 \times abc(a + b + c)}{2 \times 3 \times abc}$$

$$= 5(a + b + c)$$

Alternatively $30(a^2bc + ab^2c + abc^2) \div 6abc$

$$= \frac{30a^2bc}{6abc} + \frac{30ab^2c}{6abc} + \frac{30abc^2}{6abc}$$

$$= 5a + 5b + 5c$$

$$= 5(a + b + c)$$

12.10 Division of Expression by Expression:

Consider $(3a^2 + 21a) \div (a+7)$

Let us first factorize $3a^2 + 21a$ to check and match factors with the denominator

$$(3a^2 + 21a) \div (a+7) = \frac{3a^2 + 21a}{a+7}$$

$$= \frac{3a(a+7)}{a+7} = 3a$$

$$= 3a$$

Example 14: Divide $39y^3(50y^2 - 98)$ by $26y^2(5y+7)$

Solution : $39y^3(50y^2 - 98) = 3 \times 13 \times y \times y \times y \times [2(25y^2 - 49)]$

$$= 2 \times 3 \times 13 \times y \times y \times y \times [(5y)^2 - (7)^2]$$

$a^2 - b^2 = (a+b)(a-b)$

$$= 2 \times 3 \times 13 \times y \times y \times y \times [(5y + 7)(5y - 7)]$$

$$= 2 \times 3 \times 13 \times y \times y \times y \times (5y + 7)(5y - 7)$$

Also $26y^2(5y + 7) = 2 \times 13 \times y \times y \times (5y + 7)$

$$\begin{aligned}
 \therefore [39y^3(50y^2 - 98)] \div [26y^2(5y + 7)] \\
 &= \frac{[2 \times 3 \times 13 \times y \times y \times y(5y + 7)(5y - 7)]}{[2 \times 13 \times y \times y \times (5y + 7)]} \\
 &= 3y(5y - 7)
 \end{aligned}$$

Example 15: Divide $m^2 - 14m - 32$ by $m + 2$

Solution :

$$\begin{aligned}
 \text{Here } m^2 - 14m - 32 &= m^2 - 16m + 2m - 32 \\
 &= m(m - 16) + 2(m - 16) \\
 &= (m - 16)(m + 2) \\
 (m^2 - 14m - 32) \div (m + 2) &= (m - 16)(m + 2) \div (m + 2) \\
 &= (m - 16)
 \end{aligned}$$

Example 16: Divide $42(a^4 - 13a^3 + 36a^2)$ by $7a(a - 4)$

Solution :

$$\begin{aligned}
 42(a^4 - 13a^3 + 36a^2) &= 2 \times 3 \times 7 \times a \times a \times (a^2 - 13a + 36) \\
 &= 2 \times 3 \times 7 \times a \times a \times (a^2 - 9a - 4a + 36) \\
 &= 2 \times 3 \times 7 \times a \times a \times [a(a - 9) - 4(a - 9)] \\
 &= 2 \times 3 \times 7 \times a \times a \times [(a - 9)(a - 4)] \\
 &= 2 \times 3 \times 7 \times a \times a \times (a - 9)(a - 4) \\
 42(a^4 - 13a^3 + 36a^2) \div 7a(a - 4) &= 2 \times 3 \times 7 \times a \times a \times (a - 9)(a - 4) \div 7a(a - 4) \\
 &= 6a(a - 9)
 \end{aligned}$$

Example 17: Divide $x(3x^2 - 108)$ by $3x(x - 6)$

Solution :

$$\begin{aligned}
 x(3x^2 - 108) &= x \times [3(x^2 - 36)] \\
 &= x \times [3(x^2 - 6^2)] \\
 &= x \times [3(x + 6)(x - 6)] \\
 &= 3 \times x \times [(x + 6)(x - 6)] \\
 x(3x^2 - 108) \div 3x(x - 6) &= 3 \times x \times [(x + 6)(x - 6)] \div 3x(x - 6) \\
 &= (x + 6)
 \end{aligned}$$



Exercise - 12.3

- Carry out the following divisions
 - $48a^3$ by $6a$
 - $14x^3$ by $42x^2$
 - $72a^3b^4c^5$ by $8ab^2c^3$
 - $11xy^2z^3$ by $55xyz$
 - $-54l^4m^3n^2$ by $9l^2m^2n^2$
- Divide the given polynomial by the given monomial
 - $(3x^2 - 2x) \div x$
 - $(5a^3b - 7ab^3) \div ab$
 - $(25x^5 - 15x^4) \div 5x^3$
 - $(4l^5 - 6l^4 + 8l^3) \div 2l^2$
 - $15(a^3b^2c^2 - a^2b^3c^2 + a^2b^2c^3) \div 3abc$
 - $(3p^3 - 9p^2q - 6pq^2) \div (-3p)$
 - $(\frac{2}{3}a^2b^2c^2 + \frac{4}{3}ab^2c^2) \div \frac{1}{2}abc$
- Workout the following divisions :
 - $(49x - 63) \div 7$
 - $12x(8x - 20) \div 4(2x - 5)$
 - $11a^3b^3(7c - 35) \div 3a^2b^2(c - 5)$
 - $54lmn(l + m)(m + n)(n + l) \div 8lmn(l + m)(n + l)$
 - $36(x + 4)(x^2 + 7x + 10) \div 9(x + 4)$
 - $a(a + 1)(a + 2)(a + 3) \div a(a + 3)$
- Factorize the expressions and divide them as directed :
 - $(x^2 + 7x + 12) \div (x + 3)$
 - $(x^2 - 8x + 12) \div (x - 6)$
 - $(p^2 + 5p + 4) \div (p + 1)$
 - $15ab(a^2 - 7a + 10) \div 3b(a - 2)$
 - $15lm(2p^2 - 2q^2) \div 3l(p + q)$
 - $26z^3(32z^2 - 18) \div 13z^2(4z - 3)$



Think Discuss and Write

While solving some problems containing algebraic expressions in different operations, some students solved as given below. Identify the errors made by them. Write correct answers.

- Srilekha solved the given equation as shown below-

$$3x + 4x + x + 2x = 90$$

$$9x = 90 \quad \therefore x = 10$$

What could you say about the correctness of the solution?

Can you identify where Srilekha has gone wrong?

2. Abraham did the following

$$\text{For } x = -4, 7x = 7 - 4 = -3$$

3. John and Reshma have done the multiplication of an algebraic expression by the following methods : verify whose multiplication is correct.

John	Reshma
(i) $3(x-4) = 3x - 4$	$3(x-4) = 3x - 12$
(ii) $(2x)^2 = 2x^2$	$(2x)^2 = 4x^2$
(iii) $(2a-3)(a+2) = 2a^2 - 6$	$(2a-3)(a+2) = 2a^2 + a - 6$
(iv) $(x+8)^2 = x^2 - 64$	$(x+8)^2 = x^2 + 16x + 64$

4. Harmeet does the division as $(a+5) \div 5 = a+1$

His friend Srikar done the same $(a+5) \div 5 = a/5 + 1$

and his friend Rosy did it this way $(a+5) \div 5 = a$

Can you guess who has done it correctly? Justify your answer



Exercise - 12.4

Find the errors and correct the following mathematical sentences

(i) $3(x-9) = 3x - 9$

(ii) $x(3x+2) = 3x^2 + 2$

(iii) $2x + 3x = 5x^2$

(iv) $2x + x + 3x = sx$

(v) $4p + 3p + 2p + p - 9p = 0$

(vi) $3x+2y = 6xy$

(vii) $(3x)^2 + 4x + 7 = 3x^2 + 4x + 7$

(viii) $(2x)^2 + 5x = 4x + 5x = 9x$

(ix) $(2a+3)^2 = 2a^2 + 6a + 9$

(x) Substitute $x = -3$ in

(a) $x^2 + 7x + 12 = (-3)^2 + 7(-3) + 12 = 9 + 4 + 12 = 25$

(b) $x^2 - 5x + 6 = (-3)^2 - 5(-3) + 6 = 9 - 15 + 6 = 0$

(c) $x^2 + 5x = (-3)^2 + 5(-3) + 6 = -9 - 15 = -24$

$$(xi) (x - 4)^2 = x^2 - 16$$

$$(xii) (x + 7)^2 = x^2 + 49$$

$$(xiii) (3a + 4b)(a - b) = 3a^2 - 4a^2 \quad (xiv) (x + 4)(x + 2) = x^2 + 8$$

$$(xv) (x - 4)(x - 2) = x^2 - 8 \quad (xvi) 5x^3 \div 5x^3 = 0$$

$$(xvii) 2x^3 + 1 \div 2x^3 = 1$$

$$(xviii) 3x + 2 \div 3x = \frac{2}{3x}$$

$$(xix) 3x + 5 \div 3 = 5$$

$$(xx) \frac{4x + 3}{3} = x + 1$$



What we have discussed

1. Factorisation is a process of writing the given expression as a product of its factors.
2. A factor which cannot be further expressed as product of factors is an irreducible factor.
3. Expressions which can be transformed into the form: $a^2 + 2ab + b^2$; $a^2 - 2ab + b^2$; $a^2 - b^2$ and $x^2 + (a + b)x + ab$ can be factorised by using identities.
4. If the given expression is of the form $x^2 + (a + b)x + ab$, then its factorisation is $(x + a)(x + b)$
5. Division is the inverse of multiplication. This concept is also applicable to the division of algebraic expressions.



Gold Bach Conjecture

Gold Bach found from observation that every odd number seems to be either a prime or the sum of a prime and twice a square.

Thus $21 = 19 + 2$ or $13 + 8$ or $3 + 18$.

It is stated that up to 9000, the only exceptions to his statement are

$5777 = 53 \times 109$ and $5993 = 13 \times 641$,

which are neither prime nor the sum of a prime and twice a square.



Y2I7G5

13.0 Introduction

We are living in a 3-dimensional space. Some of the objects around us are in 3 dimensional shape. We can differentiate 2-D shapes from 3-D shapes by observing them. Look at a poster on the wall. The surface is of rectangular shape. How many measurements does it have? It has 2 measurements, i.e. length and breadth. Look at the book. What is the shape of the book? It is in cuboid shape. It has 3 measurements. Along with length and breadth it has one more measurement i.e. height. A triangle, square, rectangle are plane figures of 2-dimensions. While a cube, cuboid are solid objects with 3 dimensions. By arranging 2-D objects one above another it occupies some space and become a 3-D object as in adjacent fig.

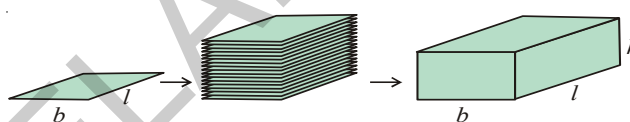

Do This

1. Name some 3-Dimensional, objects.
2. Give some examples of 2-Dimensional figures.
3. Draw a kite in your note book. Is it 2-D figure or 3-D object?
4. Identify some objects which are in cube or cuboid shape.
5. How many dimensions that a circle and sphere have?

13.1 3-D Objects made with cubes

Observe the following solid shapes. Both are formed by arranging four unit cubes.

If we observe them from different positions, it seems to be different. But the object is same.

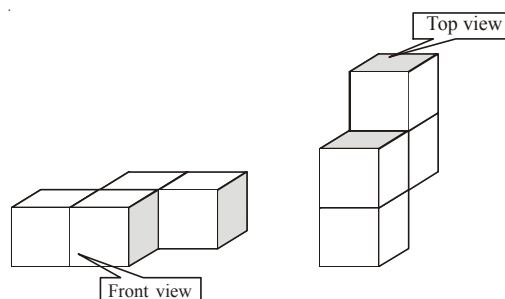

Similarly if a solid is viewed from different directions it appears in different shapes. For example-

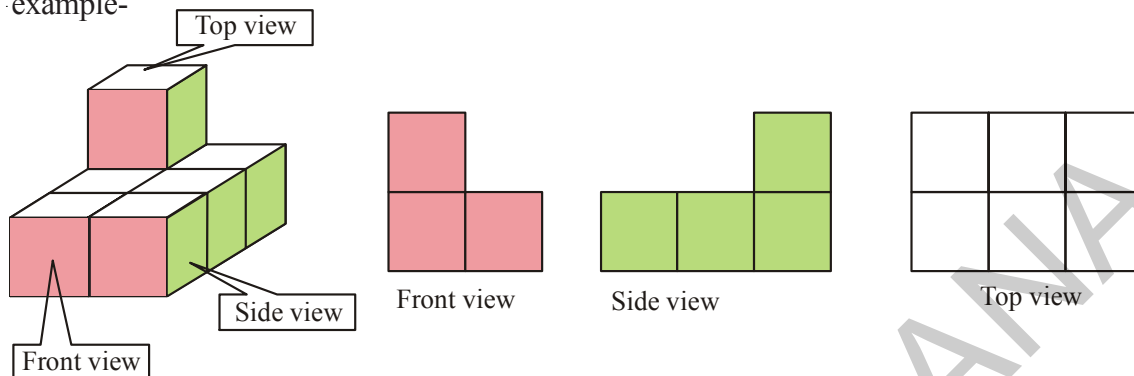

Do This

Arrange 6 unit cubes in different shapes and draw their shapes from different directions.

13.2 Representation of 3-D figures on 2-D

We used to draw 3-D figures on the paper, which is a 2-D. Actually we are able to represent only two dimensions on the plane paper, third dimension is only our imagination. We have practiced showing 3-D cube object as in adjacent figure. All edges of the cube are equal in length. But in the adjacent figure they are not equal. It has been drawn according to our view.

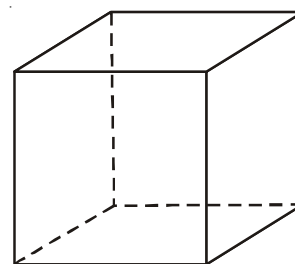

In order to overcome this problem we use isometric dots paper, in which we can represent length, breadth and height with exact measurement of 3-D solid objects.

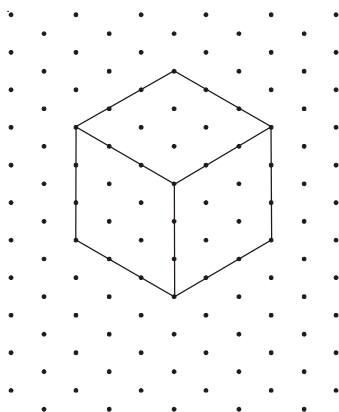

Example 1 : Identify the number of cubes in the adjacent figure.

Solution : There are three layers of cubes.

In the top layer, there is only one cube. In the second layer, there are 3 cubes (1 is hidden). In the lower layer, there are 6 cubes (3 are hidden). So total number of cubes = $1 + 3 + 6 = 10$ cubes.

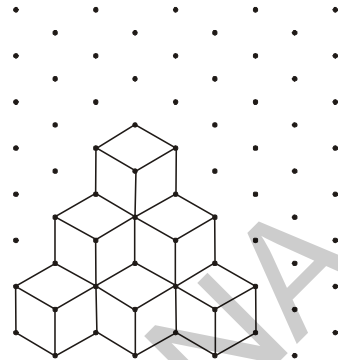

Example 2 : Find the measurements of cuboid in the adjacent figure. (Considering the distance between every two consecutive dots to be 1 unit.) Also draw a side view, front view and top view with proportional measurements.

Solution : Length of the cuboid $l = 6$ units
 Breadth of the cuboid $b = 2$ units
 Height of the cuboid $h = 3$ units.

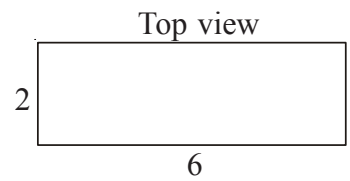
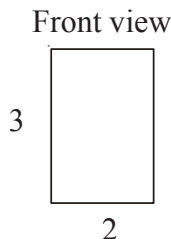
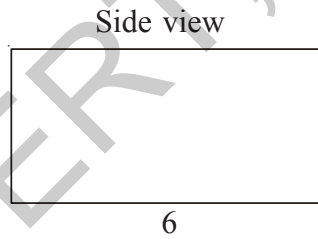
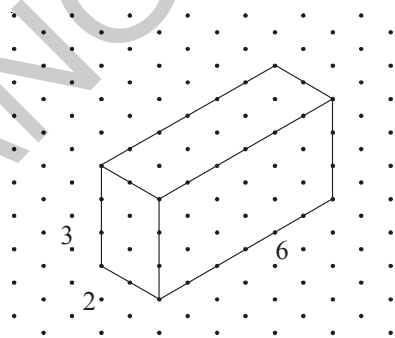

Example 3 : Look at the adjacent figure. Find the number of unit cubes in cube A and cube B and find the ratio.

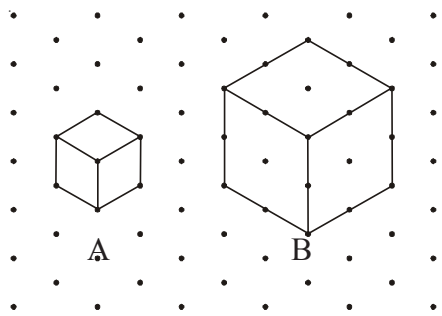

Solution : There is only one unit cube in A. In figure B, by drawing parallel lines to all side, let us divide it into unit cubes and count. There are two layers, and each layer has 4 unit cubes. So number of unit cubes in B is 8; \therefore ratio of unit cubes in A to that of B = 1 : 8.

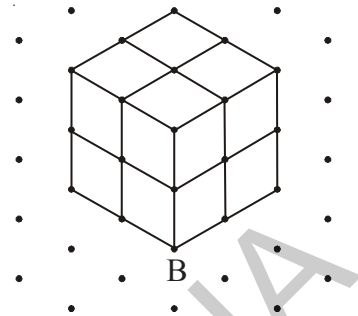

Example 4 : A house design given on isometric dot sheet in adjacent figure. Measure length, breadth and height of the house. Slab is projected forward. Find the area of the slab.

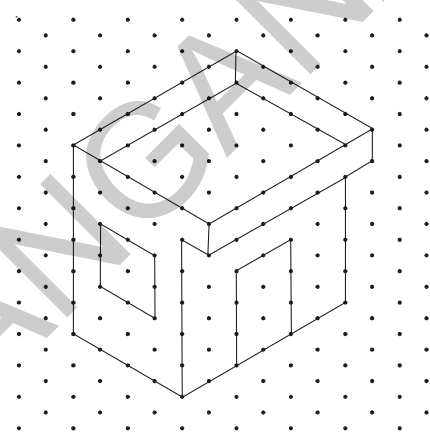

Solution : Length of the house = 6 units
 Breadth of the house = 4 units
 Height of the house = 5 units
 Slab is projected forward for 1 unit
 Dimensions of slab = 5 × 6 unit
 Area of the slab = 5 × 6 = 30 sq. units.



Exercise - 13.1

1. Draw the following 3-D figures on isometric dot sheet.

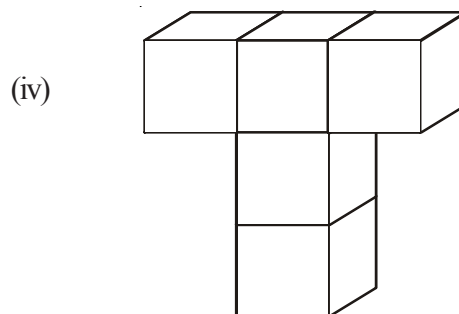
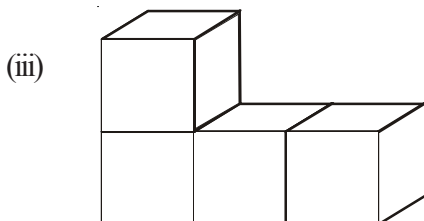
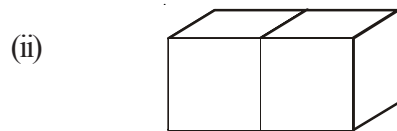

- Draw a cuboid on the isometric dot sheet with the measurements 5 units \times 3 units \times 2 units.
- Find the number of unit cubes in the following 3-D figures.

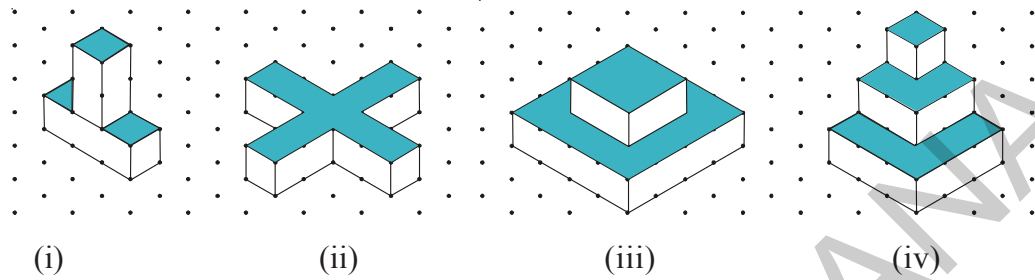

- Find the areas of the shaded regions of the 3-D figures given in question number 3.
- Consider the distance between two consecutive dots to be 1 cm and draw the front view, side view and top view of the following 3-D figures.

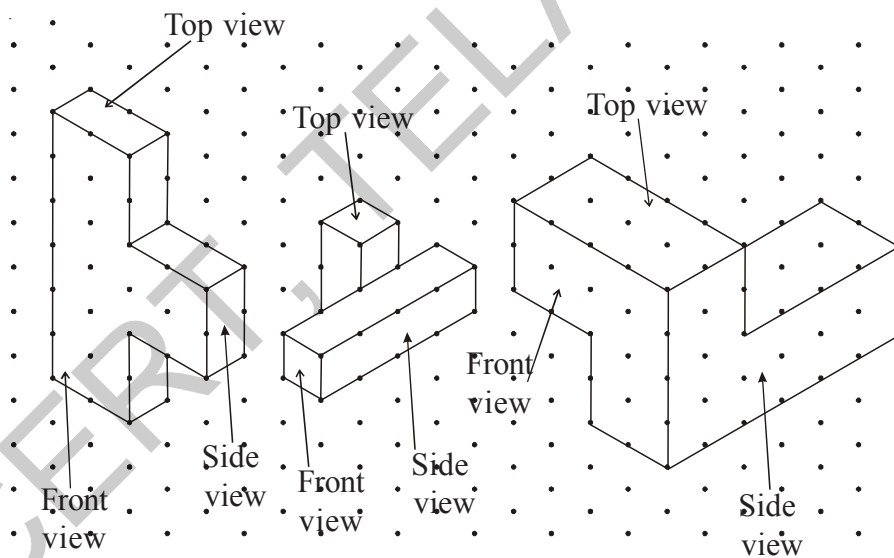

13.3 Various Geometrical Solids

In our surroundings we see various solid objects. Among them some solid objects have curved faces and some solid objects have flat faces. The 3-D objects like box, book, dice, have flat faces. The 3-D objects like ball, pipe etc have curved surfaces. Based on this property we can classify 3-D shapes as polyhedra and non-polyhedra.

Observe the following objects.

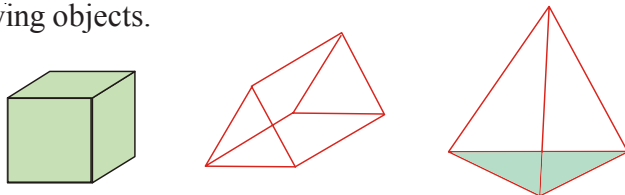

Are there any curved faces for above solids?

No, all these have only flat surfaces. This type of solid objects with all polygonal faces are called polyhedra (singular is polyhedron)

Now observe these figures.

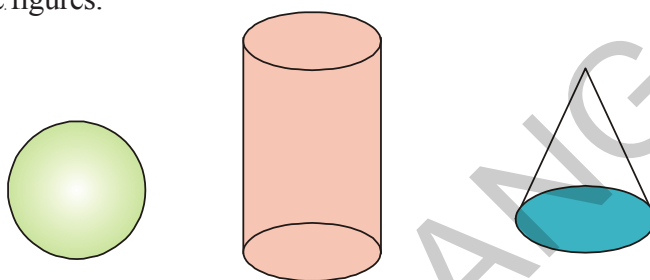

These objects have curved faces. This type of solid objects are called non-polyhedra.



Try This

1. Name three things which are the examples of polyhedron.
2. Name three things which are the examples of non-polyhedron.

13.4 Faces, Edges and Vertices of 3D-Objects

Observe the walls, windows, doors, floor, top, corners etc of our living room and tables, boxes etc. Their faces are flat faces. The flat faces meet at its edges. Two or more edges meet at corners. Each of the corner is called vertex. Take a cube and pyramid, observe them where the faces meet? Where the edges meet?

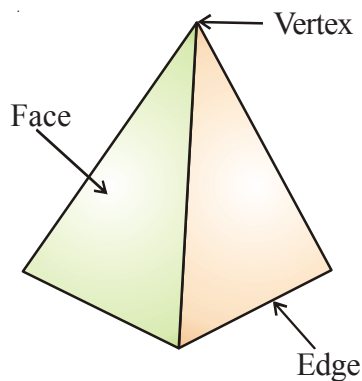
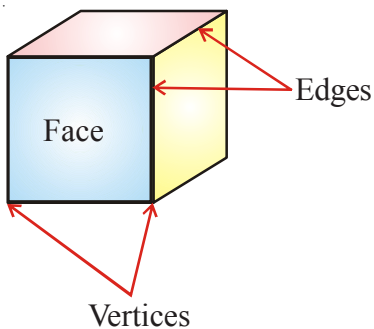



Do These

Identify the faces, edges and vertices of following figures.

1.

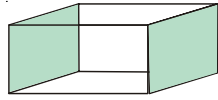

2.

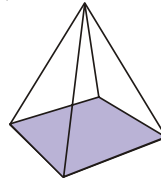

3.

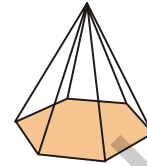

4.

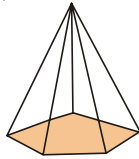

5.

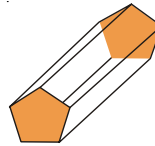

13.5 Regular Polyhedron

Observe the faces, edges and vertices in the following shapes.

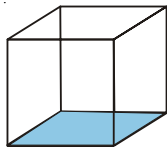

Cube

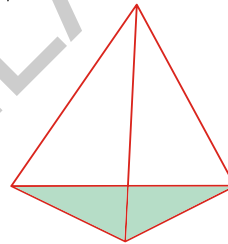

Triangular Pyramid (Tetrahedron)

In each of the above two objects, all their faces are congruent. All their edges are equal and vertices are formed by equal number of edges. Such type of solid objects are called regular polyhedra. Now observe these figures.

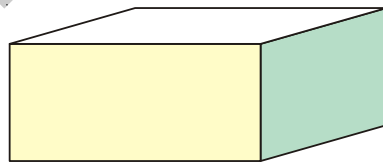

Cuboid

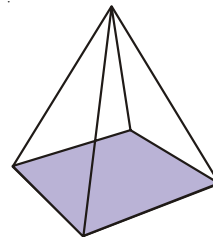

Square Pyramid

Cuboid is a non-regular polyhedra because all its faces are not congruent and in the square pyramid the one vertex formed by 4 edges and other vertices formed by 3 edges. More over all the faces in pyramid or not congruent. It is also not a regular polyhedra. These type of objects are non-regular polyhedra. Thus polyhedra can be classified into regular polyhedra and non-regular polyhedra.

13.5.1 Prism and Pyramid

Now observe the following objects

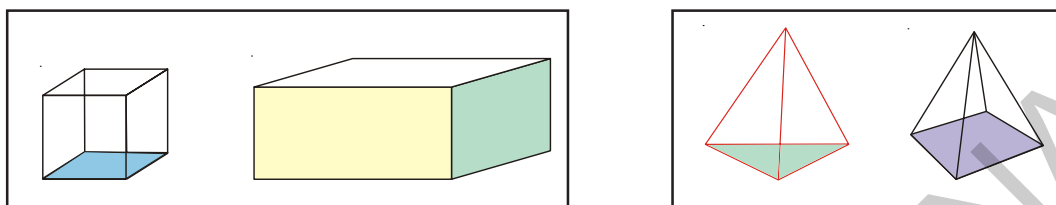

The objects in first box have same faces at top and bottom. The objects in the second box have base but the top is a common vertex. Let us observe some more objects like this.

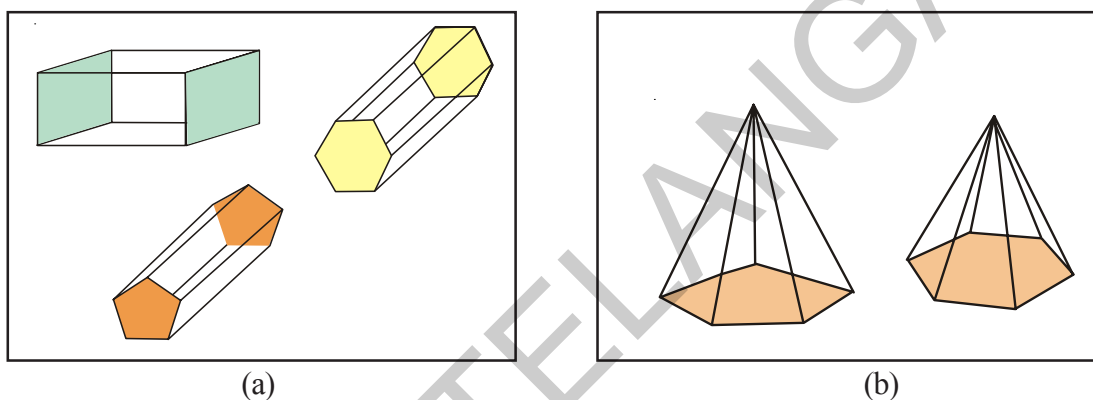

In fig (a) each object has two parallel and congruent polygonal faces, and the lateral faces are rectangles (or Parallelograms). In fig (b) The base is a polygon and lateral faces are triangles, they meet at a common vertex. The solid object with two parallel and congruent polygonal faces and lateral faces as rectangles or parallelograms is called a **prism**.

A solid object whose base is a polygon and its lateral faces are triangular faces is called **pyramid**.

A prism or pyramid is named after its shape of parallel and congruent polygonal faces or the base.

A. Triangular Prism

What is the shape of two congruent and parallel faces in the adjacent figure? And what is the shape of its lateral faces?

Its two congruent and parallel faces are triangular and its lateral faces are parallelograms. This is known as triangular prism.

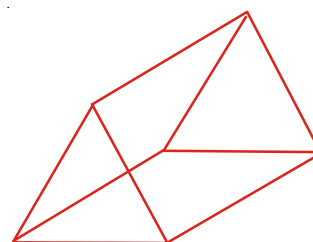

If the base is a square , it is called square prism. If the base is a pentagon , it is called pentagonal prism.

B. Triangular Pyramid

A pyramid whose base is a triangle is called triangular pyramid. It is known as tetrahedron. (Tetra-means having four faces) If the base of a pyramid is square , it is called as square pyramid.

If the base of a pyramid is a pentagon , it is called as pentagonal pyramid.

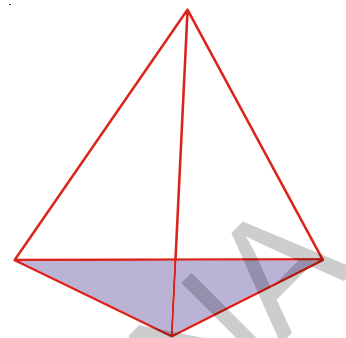

Do This

1. Write the names of the prisms given below:

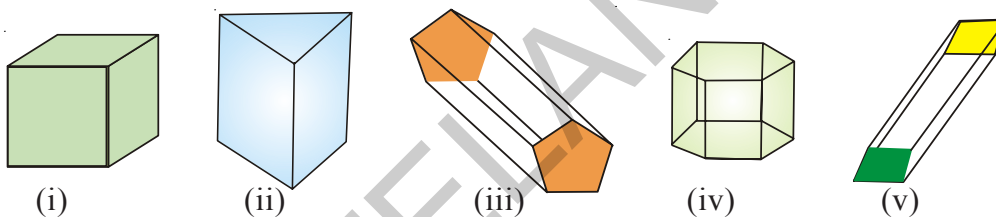

2. Write the names of the pyramids given below:

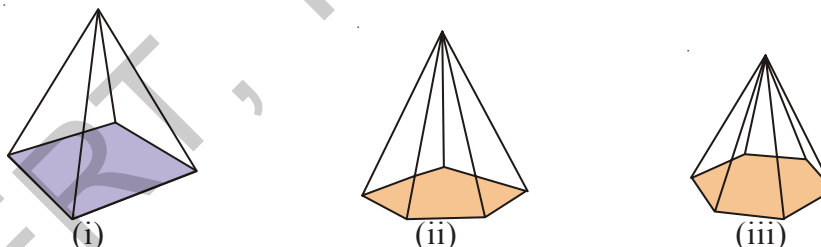

3. Fill the table.

Number of sides of prism/ pyramid	Name of the prism	Name of the pyramid
3 sides		
4 sides		
5 sides		
6 sides		
8 sides		

4. Explain the difference between prism and pyramid.



Think Discuss and write

If the number of sides of a polygonal base of a regular pyramid are infinitely increased what would be the shape of the pyramid?

13.6 Number of Edges , Faces and Vertices of polyhedrons

Let us count the number of faces, edges and vertices of a polyhedron

- Number of faces = (5) faces
- Number of edges = (9) edges
- Number of vertices = (6) vertices

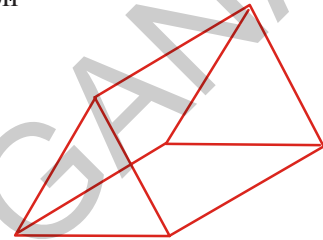

Observe and complete the table.

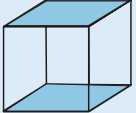
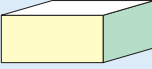
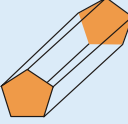
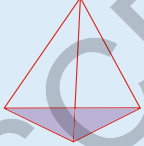
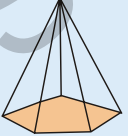
Diagram of object	Name of the object	Number of Faces (F)	Number of Vertices (V)	Number of Edges (E)	F+V	E+2
	Cube	6	8	12	$6 + 8 = 14$	$12 + 2 = 14$
	Cuboid					
	Pentagonal Prism					
	Tetra hedron					
	Pentagonal Pyramid					

By observing the last two columns of the above table. We can conclude that

$$F + V = E + 2 \text{ for all polyhedra.}$$

The relation was first observed by the mathematician Leonhard Euler (pronounced as Oiler).

He stated that $F + V = E + 2$. This relation ship is called “**Euler’s relation**” for polyhedra.

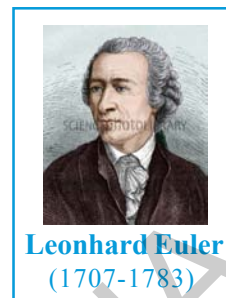

13.7 Net Diagrams

A net is a sort of skeleton - outline in 2-D, which, when folded gives a 3-D shape.

We can make prisms, pyramids by using net diagrams. Observe the activity given below to make a triangular pyramid.

Take a piece of paper and cut into a triangle. Mark the vertices as O_1, O_2, O_3 and identify the mid points of sides as A, B, C.

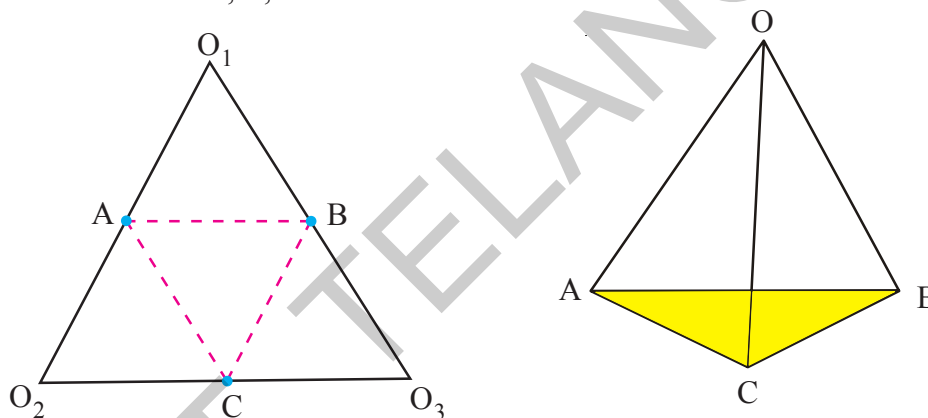

Fold the paper along dotted lines AB, BC, CA and raise the folds till the points O_1, O_2, O_3 meet at ‘O’. By this AO_1 coincides with AO_2 , BO_1 with BO_3 and CO_2 with CO_3 .

The object so formed is a pyramid. The diagram O_1, O_2, O_3 is a net diagram of the pyramid.



Exercise - 13.2

- Count the number of faces, vertices, and edges of given polyhedra and verify Euler’s formula.

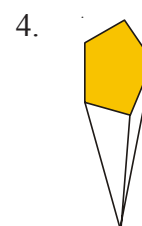
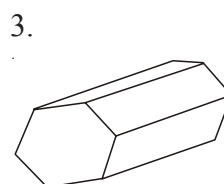
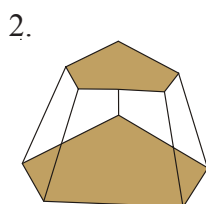
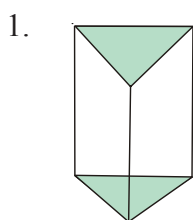

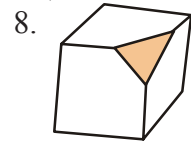
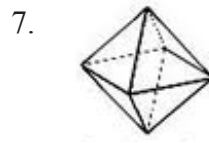
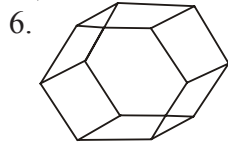
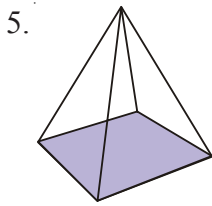



2. Is a square prism and cube are same? explain.
3. Can a polyhedra have 3 triangular faces only? explain.
4. Can a polyhedra have 4 triangular faces only? explain.
5. Complete the table by using Euler's formula.

F	8	5	?
V	6	?	12
E	?	9	30

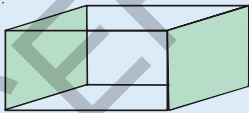
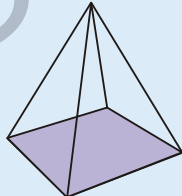
6. Can a polyhedra have 10 faces , 20 edges and 15 vertices ?
7. Complete the following table

Object	No. of vertices	No. of edges
		
		
		

8. Name the 3-D objects or shapes that can be formed from the following nets.

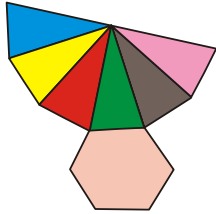

(i)

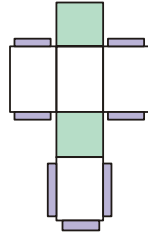

(ii)

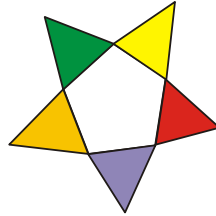

(iii)

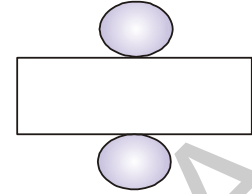

(iv)

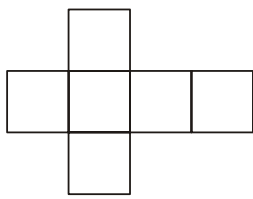

(v)

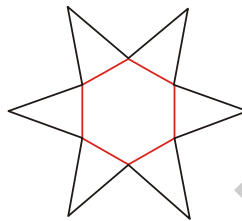

(vi)

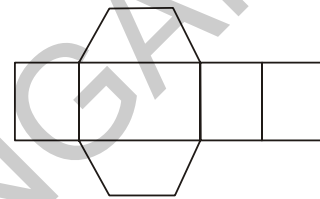

(vii)

9. Draw the following diagram on the check ruled book and find out which of the following diagrams makes cube ?

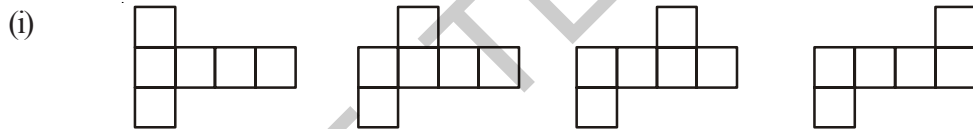

(a)

(b)

(c)

(d)

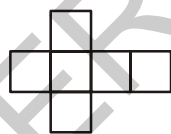

(e)

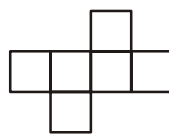

(f)

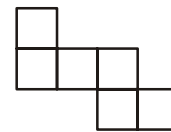

(g)

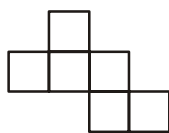

(h)

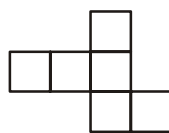

(i)

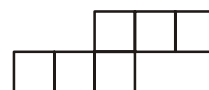

(j)

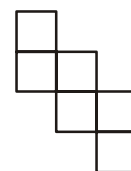

(k)

(ii). Answer the following questions.

- Name the polyhedron which has four vertices, four faces?
- Name the solid object which has no vertex?
- Name the polyhedron which has 12 edges?
- Name the solid object which has one surface?
- How a cube is different from cuboid?
- Name the two shapes which have the same number of edges, vertices and faces.
- Name the polyhedron which has 5 vertices and 5 faces?

(iii). Write the names of the objects given below .

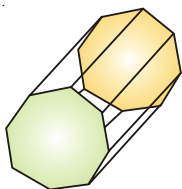

(a)

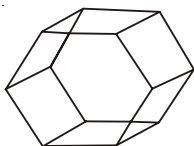

(b)

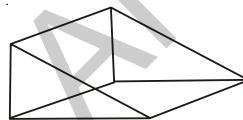

(c)



(d)



What we have discussed

- How to draw 3-D objects on 2-D isometric dot paper.
- Three different views of 3-D shapes are top view, side view and front view.
- Polyhedron : Solid objects having flat surfaces.
- Prism : The polyhedra that have top and base as the same polygon and other faces that are rectangular.
- Pyramids : Polyhedron that have a polygon as the base and a vertex with all other faces as triangles.
- 3-D objects can be made by using 2-D nets.
- Euler's formula for polyhedra : $E + 2 = F + V$.



Do you Know?

There are only five regular polyhedra, all of them are complex, often referred as **Platonic solids** as a tribute to Plato

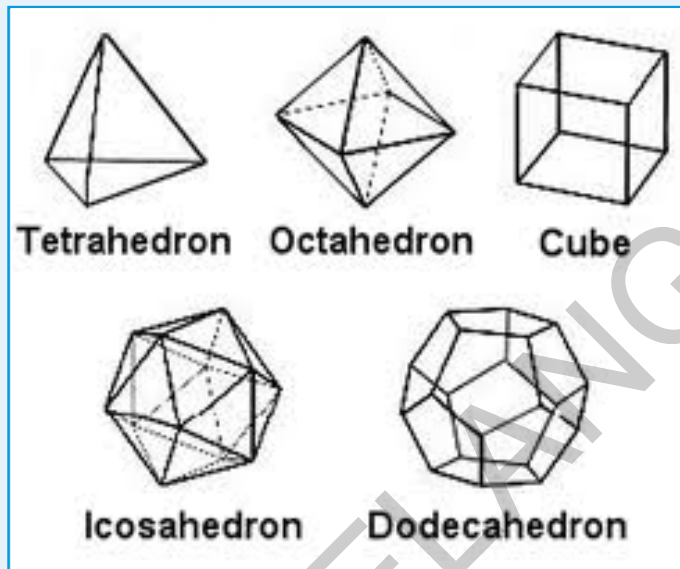

Cube is the only polyhedron to completely fill the space.

Net diagrams of Platonic Solids

Polyhedron Name	Face of polygons	Net diagram
Tetrahedron	4 Triangles	
Octahedron	8 Triangles	
Cube	6 Squares	
Icosahedron	20 Triangles	
Dodecahedron	12 Pentagons	



14.0 Introduction

Suresh wants to wrap up his gift box. One of his friends suggested to buy 100 cm^2 paper another friend suggested to buy 200 cm^2 . Whose suggestion is correct? How would he know that how much paper he has to buy?

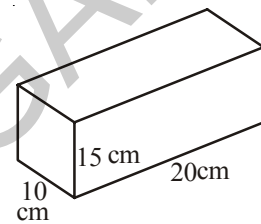

It is obvious that size of the paper required depends on the surface area of the gift box.

In order to help ourselves in such situations, let us find the ways of calculating the surface areas of different solid objects.

14.1 Cuboid

Take a cuboid shaped box made up of thick paper or cardboard for example toothpaste box.

Cut and open it as shown in figure. Observe its shape of the faces. How many sets of identical faces are found?

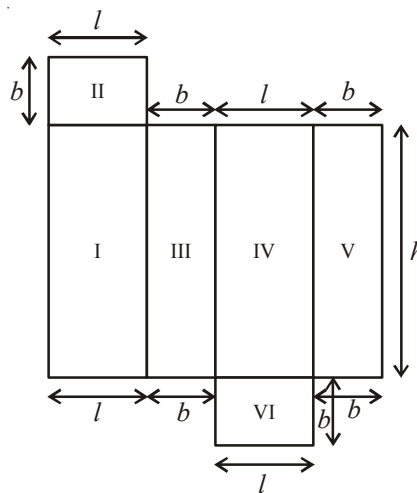
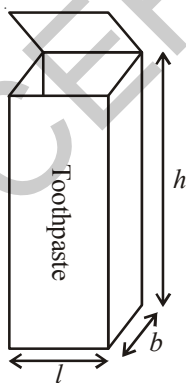

Look at the figure, if length ' l ', breadth ' b ', height ' h ' are its dimensions, then you can find three pairs of identical faces.

Now we can see that the total surface area of a cuboid is

Area I + Area II + Area III + Area IV + Area V + Area VI

$$= h \times l + l \times b + b \times h + l \times h + b \times h + l \times b$$

So total surface area = $2(h \times l + b \times h + l \times b)$

$$= 2(lb + bh + hl)$$

The height, length and the breadth of the gift box are 20cm, 10cm and 15cm respectively.

Then the Total Surface Area(T.S.A) = $2(20 \times 10 + 10 \times 15 + 15 \times 20)$

of the box

$$= 2(200 + 150 + 300)$$

$$= 2(650) = 1300 \text{ cm}^2$$

Do This

1. Find the total surface area of the following cuboid.

(i)

(ii)

14.1.2 Lateral Surface Area

- The lateral faces (the faces excluding the top and bottom) make the lateral surface area of the cuboid. For example, the total area of all the four walls of the cuboidal room in which you are sitting is the lateral surface area of the room.

Hence, the Lateral Surface Area of a cuboid

$$(L.S.A.) = (l \times h) + (b \times h) + (l \times h) + (b \times h)$$

$$= 2lh + 2bh$$

$$= 2h(l + b)$$

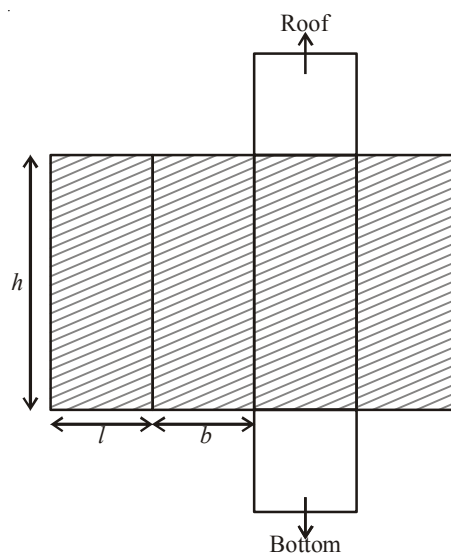



Try These

- (i) Take cuboid shaped duster (which your teacher uses in the class room). Measure its sides with scale and find out its surface area.
- (ii) Cover this duster with a graph paper, such that it just fits around the surface. Count the squares and verify the area you have calculated.
- (ii) Measure length, width and height of your classroom and find
 - (a) The total surface area of the room, ignoring the area of windows and doors
 - (b) The lateral surface area of the room
 - (c) The total area of the room which is to be white washed.



Think, Discuss and Write

1. Can we say that the total surface area of cuboid
= lateral surface area + $2 \times$ area of base.
2. If we change the position of cuboid from (Fig. (i) to Fig. (ii) do the lateral surface areas become equal?
3. Draw a figure of cuboid whose dimensions are l, b, h are equal. Derive the formula for LSA and TSA.

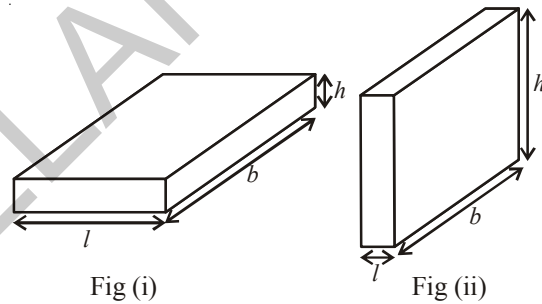

14.2 Cube

Draw the net Fig. (i) given below, on a graph paper and cut it out. Fold it along the lines as shown in Fig. (i) and join the edges as shown in Fig(ii) and Fig. (iii). What is the shape of it? Examine its faces and its dimensions.

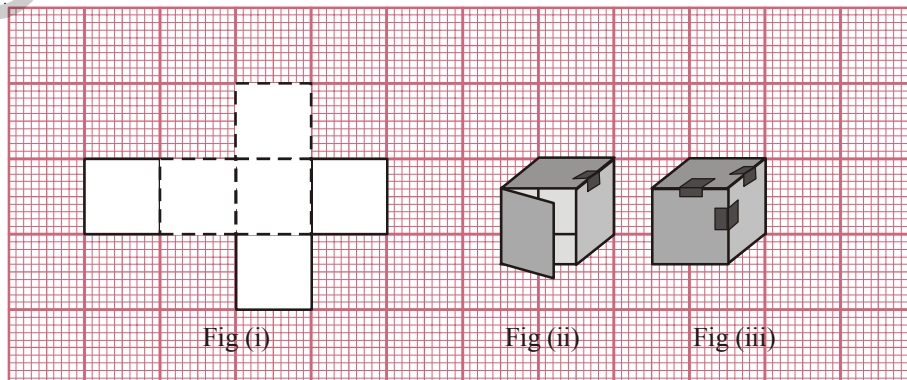

Observe the cube and its net diagram

In the figures (i) and (ii). Do all the faces of a cube are square in shape? Do the length, height and width of a cube are equal?

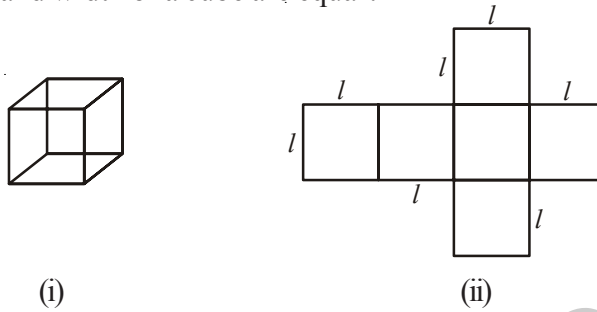

- How many faces does a cube have? Are all faces equal?
- If each side of the cube is l , what will be the area of each face?
- What is the total surface area of the cube?
- What is the lateral surface area of cube?



Try These

- Find the surface area of cube 'A' and lateral surface area of cube 'B'

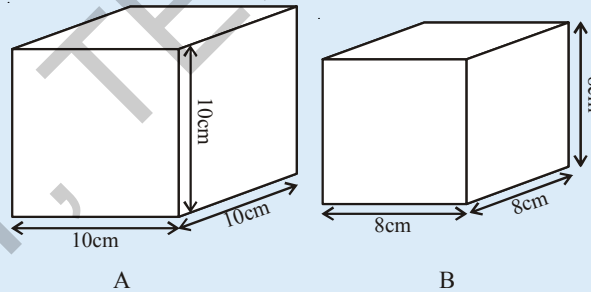

- Two cubes each with side ' b ' are joined to form a cuboid as shown in the adjacent fig. What is the total surface area of this cuboid?

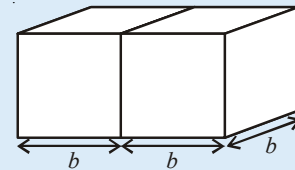

- How will you arrange 12 cubes of equal lengths to form a cuboid of smallest surface area?

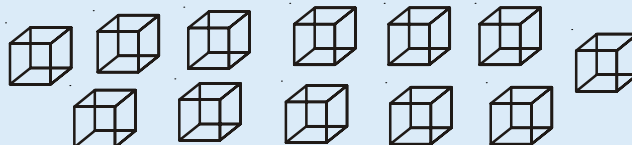

- The surface area of a cube of $4 \times 4 \times 4$ dimensions is painted. The cube is cut into 64 equal cubes. How many cubes have
 - 1 face painted?

- (b) 2 faces painted?
- (c) 3 faces painted?
- (d) no face painted ?

Example 1: Find the surface area of a cuboid whose length, breadth and height are 15cm, 12cm and 10cm respectively.

Solution: Length of the cuboid (l) = 15cm
 Breadth of the cuboid (b) = 12cm
 Height of the cuboid (h) = 10cm
 Surface area of a cuboid = $2(lb + bh + hl)$
 $= 2(15 \times 12 + 12 \times 10 + 10 \times 15) \text{ cm}^2$
 $= 2(180 + 120 + 150) \text{ cm}^2$
 $= 2(450) \text{ cm}^2$
 $= 900 \text{ cm}^2$

Example 2 : If each edge of a cube is doubled. How many times will its surface area increase?

Solution: Let the edge of the cube be ' x '
 Then edge of the new cube formed = $2x$
 Surface area of the original cube = $6x^2$
 Surface area of the new cube = $6(2x)^2$
 $= 6(4x^2) = 4(6x^2)$
 when edge is doubled
 Surface area of the new cube = $4 \times$ Surface area of the original cube
 Hence, the surface area of the new cube becomes 4 times that of the original cube.

Example 3: Two cubes each of edge 6 cm are joined face to face. Find the surface area of the cuboid thus formed.

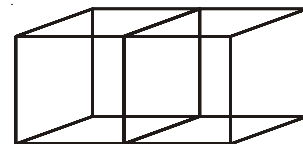

Solution: Look at the adjacent figure. Cube has six faces normally when two equal cubes are placed together, two side faces are not visible (Why?).

$$\begin{aligned} \text{We are left with } 12 - 2 &= 10 \text{ squared faces} = 10 \times l^2 \text{ cm}^2 \\ \text{So, the total surface area of the cuboid} &= 10 \times (6)^2 \text{ cm}^2 \\ &= 10 \times 36 \text{ cm}^2 = 360 \text{ cm}^2 \end{aligned}$$

Alternate Method:

If two cubes of edges 6cm are joined face to face it will take the shape of a cuboid whose length, breadth and height are (6 + 6) cm, 6cm and 6cm i.e. 12 cm, 6cm and 6cm respectively. Thus, total surface area of the cuboid

$$\begin{aligned} &= 2 (lb + bh + lh) \\ &= 2 (12 \times 6 + 6 \times 6 + 12 \times 6) \\ &= 2 (72 + 36 + 72) \\ &= 2 \times 180 \\ &= 360 \text{ cm}^2 \end{aligned}$$

Example 4: Find the cost of painting of the outer surface of a closed box which is 60 cm long, 40 cm broad and 30 cm high at the rate of 50 paise per 20cm²

Solution:

$$\begin{aligned} \text{Length of the box (} l \text{)} &= 60 \text{ cm} \\ \text{Breadth of the box (} b \text{)} &= 40 \text{ cm} \\ \text{Height of the box (} h \text{)} &= 30 \text{ cm} \\ \text{Total surface area of the box} &= 2 (lb + bh + hl) \\ &= 2 (60 \times 40 + 40 \times 30 + 60 \times 30) \\ &= 2(2400 + 1200 + 1800) \\ &= 2 \times 5400 \\ &= 10800 \text{ cm}^2 \\ \text{Cost of painting } 20 \text{ cm}^2 &= 50 \text{ paise} = ₹ \frac{50}{100} \\ \therefore \text{Cost of painting } 1 \text{ cm}^2 &= ₹ \frac{50}{100} \times \frac{1}{20} \\ \therefore \text{Cost of painting } 10800 \text{ cm}^2 &= ₹ \frac{50}{100} \times \frac{1}{20} \times 10,800 \\ &= ₹ 270 \end{aligned}$$



Exercise -14.1

- There are two cuboidal boxes as shown in the given figure. Which box requires the less amount of material to make?

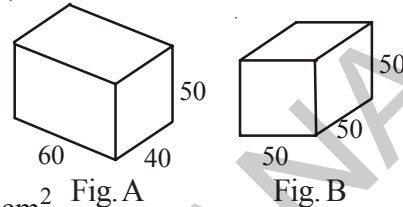

- Find the side of a cube whose surface area is 600 cm^2 .
- Prameela painted the outer surface of a cabinet of measures $1 \text{ m} \times 2 \text{ m} \times 1.5 \text{ m}$. Find the surface area she covered if she painted all surfaces except the top and bottom of the cabinet?
- Find the cost of painting a cuboid of dimensions $20 \text{ cm} \times 15 \text{ cm} \times 12 \text{ cm}$ at the rate of 5 paise per square centimeter.

14.3 Volume of Cube and Cuboid

Amount of space occupied by a three dimensional object is called its volume. Try to compare the volume of objects around you. For example, volume of a room is greater than the volume of an almirah kept in the room. Similarly, volume of your pencil box is greater than the volume of the pen and the eraser kept inside it. Do you measure volume of either of these objects?

Remember, we use square units to find the area of a region. How will we find the volume. Here we will use cubic units to find the volume of a solid, as cube is the most convenient solid shape (just as square is the most convenient shape to measure this area).

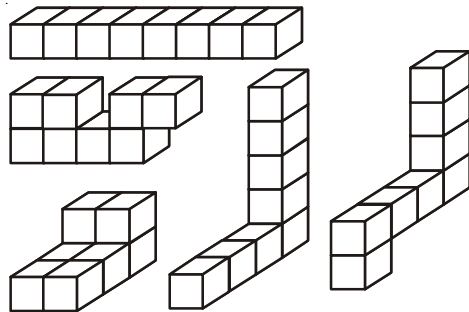

To measure the area we divide the area into square units, similarly, to find the volume of a solid we need to divide the space into cubical units. Unit cube is a cube of unit length. Observe that the volume of each of the solids which are arranged in different forms are of 8 cubic units (as in Fig above). We can say that the volume of a solid is measured by counting the number of unit cubes it contains. Cubic units which we generally use to measure the volume are

$$\begin{aligned}
 1 \text{ cubic cm} &= 1 \text{ cm} \times 1 \text{ cm} \times 1 \text{ cm} = 1 \text{ cm}^3 \\
 &= 10 \text{ mm} \times 10 \text{ mm} \times 10 \text{ mm} = \dots\dots\dots \text{ mm}^3 \\
 1 \text{ cubic m} &= 1 \text{ m} \times 1 \text{ m} \times 1 \text{ m} = 1 \text{ m}^3 \\
 &= 100 \text{ cm} \times 100 \text{ cm} \times 100 \text{ cm} = \dots\dots\dots \text{ cm}^3 \\
 1 \text{ cubic mm} &= 1 \text{ mm} \times 1 \text{ mm} \times 1 \text{ mm} = 1 \text{ mm}^3 \\
 &= 0.1 \text{ cm} \times 0.1 \text{ cm} \times 0.1 \text{ cm} = \dots\dots\dots \text{ cm}^3
 \end{aligned}$$

14.3.1 Volume of a Cuboid

Take 36 cubes of equal size (i.e., side of each cube is same). Arrange them to form a cuboid. You can arrange them in many ways. Observe the following table and fill in the blanks.

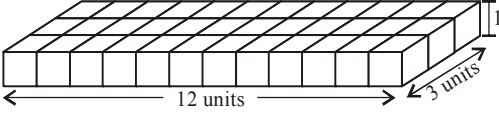
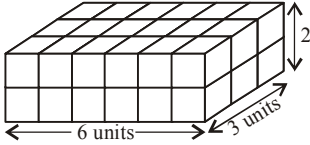
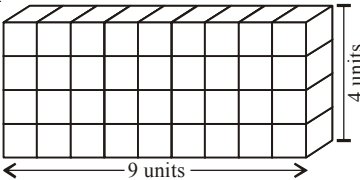
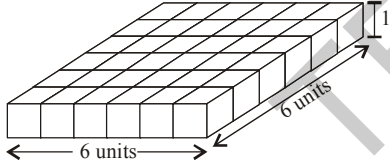
	Cuboid	length (l)	breadth (b)	height (h)	Total no. of unit cubes $l \times b \times h = V$
(i)		12	3	1	$12 \times 3 \times 1 = 36$
(ii)	
(iii)	
(iv)	

What do you observe? Do you find any relation between the dimensions of the cuboid and its volume?

Since we have used 36 cubes to form these cuboids, thus volume of each cuboid is 36 cubic units. This is equal to the product of length, breadth and height of the cuboid. From the above example we can say volume of cuboid = $l \times b \times h$. Since $l \times b$ is the area of its base we can also say that,

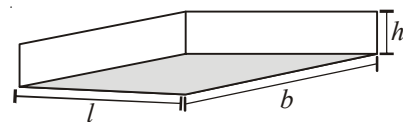

Volume of cuboid = Area of the base \times height

Activity

Take a sheet of paper. Measure its area. Pile up such sheets of paper of same size to make a cuboid (as in adjacent figure). Measure the height of this pile. Find the volume of the cuboid by finding the product of the area of the sheet and the height of this pile of sheets. Can you find the volume of paper sheet?

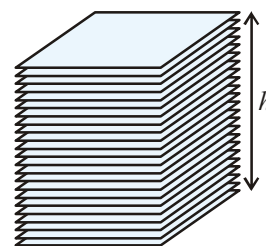
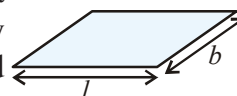



Do This

Let us find the volume of a cuboid whose length, breadth and height are 6cm., 4cm and 5cm respectively.

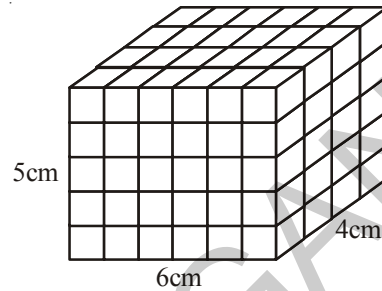
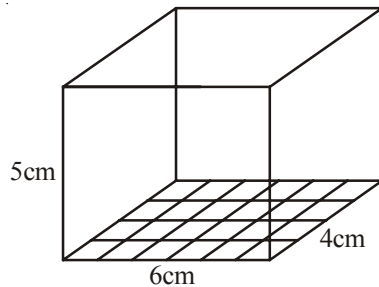

Let place 1 cubic centimeter blocks along the length of the cuboid . How many blocks can we place along the length? 6 blocks, as the length of the cuboid is 6 cm.

How many blocks can we place along its breadth? 4 blocks, as the breadth of the cuboid is 4cm. So there are 6×4 blocks can be placed in a layer.

How many layers of blocks can be placed in the cuboid? 5 layers, as the height of the cuboid is 5 cm. Each layer has 6×4 blocks. So, all the 5 layers will have $6 \times 4 \times 5$ blocks i.e. length \times breadth \times height.

This discussion leads us to the formula for the volume of a cuboid:

Volume of a Cuboid = length \times breadth \times height

14.3.2 Volume of a Cube

A Cube is a cuboid whose length, breadth and height are same,

So Volume of a cube = side \times side \times side

= (side)³ = a³ where 'a' is the side of the cube.

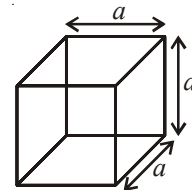

Length of Cube	Volume of the Cube
10mm = 1cm	1000 mm ³ = 1cm ³
10cm = 1dm	1000 c m ³ = 1dm ³
10dm = 1m	1000 d m ³ = 1 m ³
100cm = 1m	1000000 c m ³ = 1m ³
1000m = 1km	1000000000 m ³ = 1km ³

Generally, we measure the volumes of liquids in millilitres (ml) or litres (l)

Further $1 \text{ cm}^3 = 1 \text{ ml}$
 $1000 \text{ cm}^3 = 1 \text{ l}$
 $1 \text{ m}^3 = 1000000 \text{ cm}^3 = 1000 \text{ l}$
 $= 1 \text{ kl (kilolitre)}$

Example 5: Find the volume of a block of wood whose length is 20cm, breadth is 10 cm and height is 8 cm.

Solution: The block of wood is a cuboid and the volume of a cuboid $= l \times b \times h$
 Here, length (l) = 20 cm, breadth (b) = 10 cm, and height (h) = 8 cm
 Volume of the block = $20 \text{ cm} \times 10 \text{ cm} \times 8 \text{ cm} = 1600 \text{ cm}^3$

Example 6: A water tank is 1.4 m long, 1m wide and 0.7m deep. Find the volume of the tank in litres.

Solution: Length of the tank (l) = 1.4 m = 140 cm
 Breadth of the tank (b) = 1 m = 100 cm
 Depth of the tank (h) = 0.7 = 70 cm
 Volume of the tank = $l \times b \times h$
 $= (140 \times 100 \times 70) \text{ cm}^3$
 $= \frac{140 \times 100 \times 70}{1000} \text{ litres.}$
 $= 980 \text{ litres}$



Do This

Arrange 64 unit cubes in as many ways as you can to form a cuboid. Find the surface area of each arrangement. Can solid cuboid of same volume have same surface area?

Do you know?

Capacity

There is not much difference between the two words i.e volume and capacity

- (a) Volume refers to the amount of space occupied by an object.
 (b) Capacity refers to the quantity that a container holds.

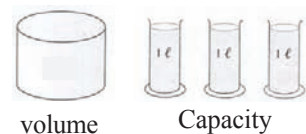

If a water tin holds 100 cm^3 of water then the capacity of the water tin is 100 cm^3 . Capacity can also measure in terms of litres.

Example 7: Find the volume of a cuboid whose breadth is half of its length and height is double the length.

Solution: Let the length of the cuboid be x units

$$\text{Then breadth of the cuboid} = \frac{x}{2} \text{ units}$$

$$\text{And height of the cuboid} = 2x \text{ units}$$

$$\text{Volume of the cuboid} = \text{length} \times \text{breadth} \times \text{height}$$

$$= x \times \frac{x}{2} \times 2x$$

$$= x^3 \text{ cubic units.}$$

Example 8: A box is 1.8 m long, 90 cm wide, 60 cm height. Soap cakes of measurements $6 \text{ cm} \times 4.5 \text{ cm} \times 40 \text{ mm}$ are to be packed in the box, so that no space is left. Find how many cakes can be packed in each box?

Solution: Length of the box (l) = 1.8 m = 180 cm

$$\text{Breadth of the box (b)} = 90 \text{ cm}$$

$$\text{Height of the box (h)} = 60 \text{ cm}$$

$$\text{Volume of the box} = l \times b \times h$$

$$= 180 \times 90 \times 60$$

$$= 972000 \text{ cm}^3$$

$$\text{Length of a soap cake} = 6 \text{ cm}$$

$$\text{Breadth of a soap cake} = 4.5 \text{ cm}$$

$$\text{Height of a soap cake} = 40 \text{ mm} = 4 \text{ cm}$$

$$\text{Volume of one soap cake} = 6 \times 4.5 \times 4$$

$$= 108.0 \text{ cm}^3$$

\therefore Required number of soap cakes

$$= \frac{\text{Volume of the box}}{\text{volume of one soapcake}}$$

$$= \frac{972000}{108}$$

$$= 9000$$

Hence, the number of soap cakes can be packed in the box = 9000

Example 9: How many cubes of side 3 cms each can be cut from wooden block in the form of a cuboid whose length, breadth and height are 21 cm, 9 cm and 8cm respectively. How much volume of wood is wasted?

Solution: Length of the cuboid (l) = 21 cm

Breadth of the cuboid (b) = 9 cm

Height of the cuboid (h) = 8 cm

Volume of cuboid = $21 \times 9 \times 8 = 1512$ cu cm.

∴ The shape of a wooden block is a cuboid

No. of cubes that can be cut along the length = $\frac{21}{3} = 7$

No. of cubes that can be cut along the breadth = $\frac{9}{3} = 3$

No. of cubes that can be cut along the height = $\frac{8}{3} = 2.6$

Along the height we can cut only 2 pieces and remaining is waste.

∴ Total number of cubes cut = $7 \times 3 \times 2$
= 42

Volume of each cube = $3 \times 3 \times 3 = 27$ cm³

Volume of all cubes = 27×42
= 1134 cm³

∴ Volume of the waste wood = $1512 - 1134 = 378$ cm³

Example 10: Water is poured into a cuboidal reservoir at the rate of 60 litres per minute. If the volume of reservoir is 108 m³. Find the number of hours it will take to fill the reservoir.

Solution: Volume of the reservoir = $108 \text{ m}^3 = 108 \times 1000$ litres

(∵ 1m³ = 1000 litres)

The reservoir is filling at the rate of 60 litres per minute.

∴ Required time = $\frac{108 \times 1000}{60}$ min.

= $\frac{108 \times 1000}{60 \times 60}$ hours = 30 hours.

Example 11 : A village has a population of 4000, requires 150 litres water per head per day. It has a tank measuring 20 m , 15 m , 6 m. How many days for the water is sufficient enough once the tank is made full?

Solution: Volume of the tank $= 20 \text{ m} \times 15 \text{ m} \times 6 \text{ m}$
 $= 1800 \text{ m}^3 = 1800000 \text{ l}$

Volume of water consumed by 1 person in 1 day = 150 l.

Total volume of water consumed in a day by total population = 150×4000

$$\text{Required number of days} = \frac{\text{Volume of the tank}}{\text{volume of water consumed in 1 day}}$$

$$= \frac{1800000}{150 \times 4000} = 3 \text{ days}$$



Exercise - 14.2

- Find the volume of the cuboid whose dimensions are given below.

	Length	Breadth	Height
(i)	8.2 m	5.3 m	2.6 m
(ii)	5.0 m	4.0 m	3.5 m
(iii)	4.5 m	2.0 m	2.5 m

- Find the capacity of the tanks with the following internal dimensions. Express the capacity in cubic meters and litres for each tank.

	Length	Breadth	Depth
(i)	3 m 20 cm	2 m 90 cm	1 m 50 cm
(ii)	2 m 50 cm	1 m 60 cm	1 m 30 cm
(iii)	7 m 30 cm	3 m 60 cm	1 m 40 cm

- What will happen to the volume of a cube if the length of its edge is reduced to half? Is the volume get reduced? If yes, how much?

4. Find the volume of each of the cube whose sides are.
 - (i) 6.4 cm
 - (ii) 1.3 m
 - (iii) 1.6 m.
5. How many bricks will be required to build a wall of 8 m long, 6m height and 22.5 cm thick, if each brick measures 25 cm by 11.25 cm by 6 cm?
6. A cuboid is 25 cm long, 15 cm broad, and 8 cm high. How much of its volume will differ from that of a cube with the edge of 16 cm?
7. A closed box is made up of wood which is 1 cm thick. The outer dimensions of the box is $5\text{ cm} \times 4\text{ cm} \times 7\text{ cm}$. Find the volume of the wood used.
8. How many cubes of edge 4cm, each can be cut out from cuboid whose length, breadth and height are 20 cm, 18 cm and 16 cm respectively
9. How many cuboids of size $4\text{ cm} \times 3\text{ cm} \times 2\text{ cm}$ can be made from a cuboid of size $12\text{ cm} \times 9\text{ cm} \times 6\text{ cm}$?
10. A vessel in the shape of a cuboid is 30 cm long and 25 cm wide. What should be its height to hold 4.5 litres of water?



What we have discussed

1. If l, b, h are the dimensions of cuboid, then:
 - (i) its lateral surface area is $2h(l + b)$
 - (ii) its total surface area is $2(lb + bh + hl)$
 - (iii) its volume is $l \times b \times h$
2. If 'a' is the length of the side of a cube, then :
 - (i) Lateral surface area = $4a^2$
 - (ii) Total surface area = $6a^2$
 - (iii) Volume = $side \times side \times side = a^3$
3. $1\text{ cm}^3 = 1\text{ ml}$
 $1\text{ l} = 1000\text{ cm}^3$
 $1\text{ m}^3 = 1000000\text{ cm}^3 = 1000\text{ l}$
 $= 1\text{ kl (kilolitre)}$





X1Q2B9

15.0 Introduction

Imagine ... a world without numbers, how would your day go ?

You will see no calendar to tell you which day of the month it is ...

You will not be able to call up your friends to say thanks, if there are no telephone numbers ! And yes! You will get tired of strangers knocking your door, since no house numbers !

These are just few examples ! Think of the other ways in which your life will go for a change in a world without numbers !

You are right . You will get late for your school and miss out yours favourite cartoons/ serials, if there would be no clocks. And yes, no cricket, no foot ball, without numbers .

So, it seems that it is not a good idea to be there without numbers. If we wish to find the cost of some article or if want to distribute something equally among your friends, how will you do?

Can you guess which of these are fundamental operations ? All these fundamental operations involve numbers, divisibility rules. The divisibility rules help us to find whether the given number is divisible by another number or not without doing division. Let us play with numbers using some fundamental operations and divisibility rules.



15.1 Divisibility Rules

Take some numbers and check them which are divisible by 2, which are divisible by 3 and so on till 7.

When a number 'a' divides a number 'b' completely, we say 'b' is divisible by 'a'.

In this chapter we will learn about divisibility of numbers and logic behind them. First recall about place value and factors.

15.1.1 Place value of a digit

Let us take a number 645 and expand it.

$$645 = 600 + 40 + 5 = 6 \times 100 + 4 \times 10 + 5 \times 1$$

In the given number, the place value of 6 is 600 and the place value of 4 is 40. There are 6 hundreds, 4 tens and 5 ones in 645.



Do this

Write the place value of numbers underlined.

- (i) 29879 (ii) 10344 (iii) 98725

15.1.2 Expanded form of numbers

We know how to write a number in expanded form. At the same time, we are familiar with how to express a number in expanded form by using powers of ten.

For example

Standard notation

Expanded form

$$68 = 60 + 8 = (10 \times 6) + 8 = (10^1 \times 6) + (10^0 \times 8)$$

$$72 = 70 + 2 = (10 \times 7) + 2 = (10^1 \times 7) + (10^0 \times 2)$$

We know that
 $10^0 = 1$

Let us consider a two digit number $10a + b$ having 'a' and 'b' respectively as tens and units digits using the above notations,

The number can be written as $(10 \times a) + b = (10^1 \times a) + (1 \times b)$. (Where $a \neq 0$)

Let us now consider a number 658, a three digit number, it can be written as

Standard notation

Expanded form

$$658 = 600 + 50 + 8 = 100 \times 6 + 10 \times 5 + 1 \times 8 = 10^2 \times 6 + 10^1 \times 5 + 1 \times 8$$

Similarly $759 = 700 + 50 + 9 = 100 \times 7 + 10 \times 5 + 1 \times 9 = 10^2 \times 7 + 10^1 \times 5 + 1 \times 9$

In general a three digit number made up of digits a, b, and c is written as

$$10^2a + 10^1b + c$$

$$= 100 \times a + 10 \times b + c = 100a + 10b + c, \text{ (where } a \neq 0\text{)}$$

We can write a number in such expanded form as

$$3456 = 3000 + 400 + 50 + 6 = 1000 \times 3 + 100 \times 4 + 10 \times 5 + 6$$

$$= 10^3 \times 3 + 10^2 \times 4 + 10^1 \times 5 + 6$$

Similarly a four digit number made up of digits a, b, c and d can be written as

$$1000a + 100b + 10c + d = 1000 \times a + 100 \times b + 10 \times c + d \text{ (where } a \neq 0\text{)}$$

$$= 10^3a + 10^2b + 10^1c + d.$$



Do These

- Write the following numbers in expanded form
 - 65
 - 74
 - 153
 - 612
- Convert the following expanded form into standard notation.
 - $10 \times 9 + 4$
 - $100 \times 7 + 10 \times 4 + 3$
- Fill in the blanks
 - $100 \times 3 + 10 \times \underline{\quad} + 7 = 357$
 - $100 \times 4 + 10 \times 5 + 1 = \underline{\quad}$
 - $100 \times \underline{\quad} + 10 \times 3 + 7 = 737$
 - $100 \times \underline{\quad} + 10 \times q + r = pqr$
 - $100 \times x + 10 \times y + z = \underline{\quad}$

15.1.3 Factors and Multiples of numbers

Write the factors of 36.

The factors of 36 are 1, 2, 3, 4, 6, 9, 12, 18, 36.

Which is the greatest factor of 36 ?

We say every factor is less than or equal to the given number

. Greatest factor of a non-zero number is the number itself.

Therefore, every number is a factor of itself. And '1' is a factor of all numbers.

$$7 \times 1 = 7, 9 \times 1 = 9,$$

If a natural number other than '1' has no factors except 1 and itself, what do you say about such numbers? Those numbers are **prime numbers**.

Ex : 2, 3, 5, 7, 11, 13,....etc.

One interesting sets of numbers 23, 4567, 89 are primes and made with consecutive digits.

Do you know?

The number 82818079787776757473727170696867666564636261605958575655545 352
 515049484746454443424140393837363534333231302928272625242322212 01918
 1716151413121110987654321 is written by starting at 82 and writing backwards to 1.
 How many digits are there in this number? It is a such big number, which is a prime number.

$$1 \times 36 = 36 \quad 4 \times 9 = 36$$

$$2 \times 18 = 36 \quad 6 \times 6 = 36$$

$$3 \times 12 = 36$$

Factorize 148 into prime factors.

$$148 = 2 \times 74 = 2 \times 2 \times 37 = 2^2 \times 37^1$$

We observe the number of factors of 148 is product of (Exponents of factors + 1) of prime factors

$$\therefore \text{No of factors } (2 + 1) \times (1 + 1) = 3 \times 2 = 6$$

The factors of 148 are 1, 2, 4, 37, 74, 148.

If a number can be written as product of primes i.e. $N = 2^a \times 3^b \times 5^c \dots$

Number of factors of N is $(a + 1)(b + 1)(c + 1) \dots$

Write the first 5 multiples of 6.

$$6 \times 1 = 6, \quad 6 \times 2 = 12, \quad 6 \times 3 = 18, \quad 6 \times 4 = 24, \quad 6 \times 5 = 30$$

6, 12, 18, 24, 30 are first five multiples of 6.

How many multiples can we write? Infinite multiples. We say number of multiples of a given number is infinite.

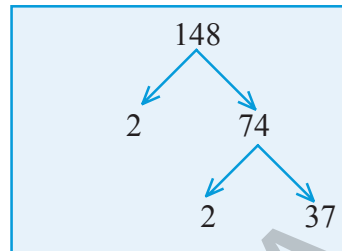

Do These

- Write all the factors of the following numbers :
(a) 24 (b) 15 (c) 21 (d) 27
(e) 12 (f) 20 (g) 18 (h) 23 (i) 36
- Write first five multiples of given numbers
(a) 5 (b) 8 (c) 9
- Factorize the following numbers into prime factors.
(a) 72 (b) 158 (c) 243

15.1.4 Divisibility by 10

Take the multiples of 10 : 10, 20, 30, 40, 50, 60,etc

In all these numbers the unit's digit is '0'

Do you say any multiple of 10 will have unit digit as zero? Therefore if the unit digit of a number is '0', then it is divisible by 10.

Let us explore the logic behind this rule.

If we take a three digit number where 'a' is in hundred's place, 'b' is in ten's place and 'c' is in unit's place can be written as $100a + 10b + c = 10(10a + b) + c$

$10(10a + b)$ is multiple of 10. If 'c' is a multiple of 10 then the given number will be divisible by 10. It is possible only if $c = 0$.



Do These

1. Check whether the following given numbers are divisible by 10 or not ?
(a) 3860 (b) 234 (c) 1200 (d) 10^3 (e) $10 + 280 + 20$
2. Check whether the given numbers are divisible by 10 or not ?
(a) 10^{10} (b) 2^{10} (c) $10^3 + 10^1$



Try This

1. In the division $56Z \div 10$ leaves remainder 6, what might be the value of Z.

15.1.5 Divisibility by 5

Take the multiples of 5. Those are 5,10,15, 20,25,30,35 ,40,45,50,.....etc

In these numbers the unit's digit is '0' or '5'

If the units digit of a number is '0' or '5' then it is divisible by 5.

Let us see the logic behind this rule .

If we take a three digit number $100a + 10b + c$ where 'a' is in hundred's place, b is in ten's place and c is in unit's place,

It can be written as $100a + 10b + c = 5(20a + 2b) + c$

$5(20a + 2b)$ is multiple of 5.

The given number is divisible by 5, only if the unit's digit $c = 0$ or 5



1. Check whether the given numbers are divisible by 5 or not ?
(a) 205 (b) 4560 (c) 402 (d) 105 (e) 235785

If 34A is divisible by 5, what might be the value of A?

In the given number the unit digit A is, either 0 or 5 then only it is divisible by 5. Hence $A = 0$ or 5.



Try These

1. If $4B \div 5$ leaves remainder 1, what might be the value of B
2. If $76C \div 5$ leaves remainder 2, what might be the value of C
3. “If a number is divisible by 10, it is also divisible by 5.” Is the statement true? Give reasons.
4. “If a number is divisible by 5, it is also divisible by 10.” Is the statement is true or false? Give reasons.

15.1.6 Divisibility by 2

Take the multiples of 2 : i.e. 2, 4, 6, 8, 10, 12, 14, 16, 18, 20,etc

In these numbers the unit's digit ends with 0,2,4,6, 8.

If the unit digit is 0 or 2 or 4 or 6 or 8 (even number) then it is divisible by 2. Otherwise it will not divisible by 2.

Let us see the logic behind this rule.

If we take a three digit number $100 \times a + 10 \times b + c$ where a in hundred's place, b is in ten's place and c is in unit's place, then it can be written as $100a + 10b + c = 2(50a + 5b) + c$

$2(50a + 5b)$ is multiple of 2. If the given number is divisible by 2, it is possible only if the unit's digit $c = 0$ or 2 or 4 or 6 or 8 (even number)



Think, Discuss and Write

1. Find the digit in the units place of a number if it is divided by 5 and 2 leaves the remainders 3 and 1 respectively.

Example 1: Write the number of factors of 60 and verify by listing the factors

Solution: 60 can be written as product of prime factors as $2^2 \times 3^1 \times 5^1$

$$\therefore \text{Number of factors are } (2 + 1)(1 + 1)(1 + 1)$$

$$= 3 \times 2 \times 2 = 12$$

The factors are 1, 2, 3, 4, 5, 6, 10, 12, 15, 20, 30, 60

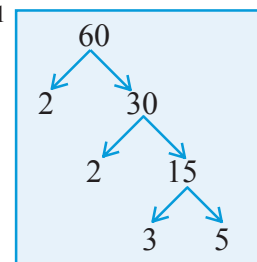



Exercise - 15.1

1. Using divisibility rules, find which of the following numbers are divisible by 2, 5, 10 (say yes or no) in the given table. What do you observe?

Number	Divisible by 2	Divisible by 5	Divisible by 10
524	YES	NO	NO
1200			
535			
836			
780			
3005			
4820			
48630			

2. Using divisibility tests, determine which of the following numbers are divisible by 2?
(a) 2144 (b) 1258 (c) 4336 (d) 633 (e) 1352
3. Using divisibility tests, determine which of the following numbers are divisible by 5?
(a) 438750 (b) 179015 (c) 125 (d) 639210 (e) 17852
4. Using divisibility tests, determine which of the following numbers are divisible by 10?
(a) 54450 (b) 10800 (c) 7138965 (d) 7016930 (e) 10101010
5. Write the number of factors for the following.
(a) 18 (b) 24 (c) 45 (d) 90 (e) 105
6. Write any 5 numbers which are divisible by 2, 5 and 10.
7. A number $34A$ is exactly divisible by 2 and leaves a remainder 1, when divided by 5, find A .

15.1.7 Divisibility by 3 and 9

Consider the number 378, it can be written as $378 = 300 + 70 + 8$

$$= 100 \times 3 + 10 \times 7 + 8$$

Here '3' can't be taken out as a common factor $= (99 + 1)3 + (9 + 1)7 + 8$

So let us reorganise the sequence as

$$\begin{aligned}
 378 &= 99 \times 3 + 9 \times 7 + (3 + 7 + 8) \\
 &= 99 \times 3 + 3 \times 3 \times 7 + (3 + 7 + 8) \\
 &= 3(99 + 21) + (3 + 7 + 8)
 \end{aligned}$$

$3(99 + 21)$ is a multiple of 3. Therefore the given number is divisible by 3 only when $(3 + 7 + 8)$ sum of digits is a multiple of 3.

For divisibility of 9:

378 can be written as

$$\begin{aligned}
 378 &= 300 + 70 + 8 \\
 &= 100 \times 3 + 10 \times 7 + 8 \\
 &= (99 + 1)3 + (9 + 1)7 + 8 \\
 &= 99 \times 3 + 9 \times 7 + (3 + 7 + 8) \\
 &= 9(11 \times 3 + 1 \times 7) + (3 + 7 + 8) \\
 &= 9(33 + 7) + (3 + 7 + 8)
 \end{aligned}$$

$9(33 + 7)$ is multiple of 9. if the given number is divisible by 9, then $(3 + 7 + 8)$, sum of digits is a multiple of 9.

Let us explain this rule :

If we take a three digit number $100a+10b+c$ where 'a' is in hundred's place , 'b' is in ten's place and 'c' is in unit's place.

$$\begin{aligned}
 100a + 10b + c &= (99 + 1)a + (9 + 1)b + c = 99a + 9b + (a + b + c) \\
 &= 9(11a + b) + (a + b + c) \rightarrow \text{sum of given digits}
 \end{aligned}$$

$9(11a + b)$ multiple of 3 and 9 .The given number is divisible by 3 or 9 , only if the sum of the digits $(a + b + c)$ is multiple of 3 or 9 respectively or $(a+b+c)$ is divisibly by 3 or 9.

Is this divisibility rule applicable for the numbers having more than 3-digits? Check by taking 5-digits and 6-digits numbers.

You have noticed that divisibility of a number by 2,5 and 10 is decided by the nature of the digit in unit place, but divisibility by 3 and 9 depends upon other digits also.



Do This

- Check whether the given numbers which are divisible by 3 or 9 or by both?

(a) 3663	(b) 186	(c) 342	(d) 18871
(e) 120	(f) 3789	(g) 4542	(h) 5779782

Example 2: $24P$ leaves remainder 1 if it is divided by 3 and leaves remainder 2 if it is divided by 5. Find the value of P .

Solution : If $24P$ is divided by 5 and leaves remainder 2, then P is either 2 or 7.

If $P = 2$ the given number when divided by 3 leaves remainder 2. If $P = 7$, the given number when divided by 3, leaves remainder 1. Hence $P = 7$.



Exercise -15.2

1. If $345A7$ is divisible by 3, supply the missing digit in place of 'A'.
2. If $2791A$, is divisible by 9, supply the missing digit in place of 'A'.
3. Write some numbers which are divisible by 2,3,5,9 and 10 also.
4. $2A8$ is a number divisible by 2, what might be the value of A ?
5. $50B$ is a number divisible by 5, what might be the value of B ?
6. $2P$ is a number which is divisible by 2 and 3, what is the value of P ?
7. $54Z$ leaves remainder 2 when divided by 5, and leaves remainder 1 when divided by 3, what is the value of Z ?
8. $27Q$ leaves remainder 3 when divided by 5 and leaves remainder 1 when divided by 2, what is the remainder when it is divided by 3?

15.1.8 Divisibility by 6

Consider a multiple of 6, say 24.

Obviously it is divisible by 6.

Is 24 divisible by the factors of 6, i.e 2 and 3?

Units place of 24 is 4, so it is divisible by 2.

Sum of digits of 24 is $2 + 4 = 6$ which is divisible by 3 also.

Now check this with some other multiple of 6.

Now we can conclude that any number divisible by 6 is also divisible by the factors of 6. i.e 2 and 3.

So if the number is divisible by 2 and 3, then 2 and 3 become its prime factors, then their product $2 \times 3 = 6$ is also a factor of that number.

In other words if a number is divisible by 6, it has to be divisible by 2 and 3.



Do These

1. Check whether the given numbers are divisible by 6 or not ?
(a) 1632 (b) 456 (c) 1008 (d) 789 (e) 369 (f) 258
2. Check whether the given numbers are divisible by 6 or not ?
(a) $458 + 676$ (b) 6^3 (c) $6^2 + 6^3$ (d) $2^2 \times 3^2$

15.1.9 Divisibility by 4 and 8

- (a) Take a four digit number say $1000a + 100b + 10c + d = 4(250a + 25b) + (10c + d)$. $4(250a + 25b)$ is a multiple of 4. The given number is divisible by 4, only if $10c+d$ is divisible by 4.

In a given number if the number formed by last two digits is divisible by 4 or last two digits are '0' then that number is divisible by 4.

Take a number having more than 4 digits and write in expanded form. Can we write the number other than unit digit and ten's digit as multiple of 4? Check for a number having more than 4 digits, divisibility of 4 depends upon its last two digits or not.

- (b) Take a four digit number $1000 \times a + 100 \times b + 10 \times c + d$
 $= 1000a + 100b + 10c + d = 8(125a) + (100b + 10c + d)$
 $8(125a)$ is always divisible by 8. So the given number is divisible by 8 only when $(100b+10c+d)$ is divisibly by 8.

In a given number if the number formed with its last 3 digits are divisible by 8 or last 3 digits are '0's then that number is divisible by 8.

Take a number having more than 4 digits and write the number in expanded form. Can we write the number other than unit's digit ten's digit and hundred's digit as multiple of 8.

Check for a number having more than 4 digits, divisibility of 8 is depends upon its last three digits or not.

Puzzle: Can you arrange the digits 1, 2, 3, 4, 5, 6, 7, 8, 9 in an order so that the number formed by first two digits is divisible by 2, the number formed by first three digits is divisible by 3, the number formed by first four digits is divisible by 4 and so on upto nine digits?

Solution : The order 123654987 looks promising check and verify.

Example 3: Check whether 6582 is divisible by 4 ?

Solution: The number formed by last two digits is 82, is not divisible by 4. Hence the given number is not divisible by 4.

Example 4: Check whether 28765432 is divisible by 8 ?

Solution : The number formed by last three digits is 432 is divisible by 8, hence it is divisible by 8.

If a number is divisible by 8, then it is divisible by 4 also. Can you say if a number divisible by 4 is it divisible by 8? All multiples of 8 are divisible by 4, but all multiples of 4 may not be divisible by 8.



Do This

1. Check whether the given numbers are divisible by 4 or 8 or by both 4 and 8?
- (a) 464 (b) 782 (c) 3688 (d) 100
(e) 1000 (f) 387856 (g) 4^4 (h) 8^3



Try This

1. Check whether the given numbers are divisible by 4 or 8 or by both 4 and 8?
- (a) $4^2 \times 8^2$ (b) 10^3 (c) $10^5 + 10^4 + 10^3$ (d) $4^3 + 4^2 + 4^1 - 2^2$

15.1.10 Divisibility by 7

Take a three digit number $100 \times a + 10 \times b + c$ can be written as

$$100a + 10b + c = 98a + 7b + (2a + 3b + c)$$

Here 7 is not a common factor, let us rewrite it in a way that 7 becomes a common factor.

$$= 7(14a + b) + (2a + 3b + c)$$

$7(14a + b)$ is multiple of '7'. The given number is divisible by 7 only when $(2a + 3b + c)$ is divisible by 7.

Example 5: Check whether 364 is divisible by 7 or not ?

Solution : Here $a = 3, b = 6, c = 4, (2a + 3b + c) = 2 \times 3 + 3 \times 6 + 4$
 $= 6 + 18 + 4 = 28$ (is divisible by 7)

Hence, the given number is divisible by '7'



Do This

- Check whether the given numbers are divisible by 7?
(a) 322 (b) 588 (c) 952 (d) 553 (e) 448



Try These

- Take a four digit general number, make the divisibility rule for '7'
- Check your rule with the number 3192 which is a multiple of 7.

15.1.11 Divisibility by 11

Take a 5 digit number $10000a + 1000b + 100c + 10d + e$

Here 11 can't be taken out as a common factor. So let us reorganise the expansion as

$$\begin{aligned} &= (9999 + 1) a + (1001 - 1) b + (99 + 1) c + (11 - 1) d + e \\ &= 9999a + 1001 b + 99c + 11d + a - b + c - d + e \\ &= 11 (909a + 91b + 9c + d) + (a + c + e) - (b + d) \\ &11 (909a + 91b + 9c + d) \text{ is always divisible by 11.} \end{aligned}$$

So the given number is divisible by 11 only if $(a + c + e) - (b + d)$ is divisible by 11.

i.e $(a + c + e) - (b + d)$ is a multiple of 11 or equal to zero.

If the difference between the sum of digits in odd places ($a + c + e$) and sum of digits in even places ($b + d$) of a number is a multiple of 11 or equal to zero, then the given number is divisible by 11.

Observe the following table

Number	Sum of the digits at odd places (from the left)	Sum of the digits at even places (from the left)	Difference
308	$3 + 8 = 11$	0	$11 - 0 = 11$
1331	$1 + 3 = 4$	$3 + 1 = 4$	$4 - 4 = 0$
61809	$6 + 8 + 9 = 23$	$1 + 0 = 1$	$23 - 1 = 22$

We observe that in each case the difference is either 0 or divisible by 11. Hence all these numbers are divisible by 11.

For the number 5081, the difference of the digits of odd places and even places is $(5+8)-(0+1)=12$ which is not divisible by 11. Therefore the number 5081 is not divisible by 11.



Do This

1. Check whether the given numbers are divisible by 11.
(i) 4867216 (ii) 12221 (iii) 100001

Consider a 3 digit number 123.

Write it two times to make a number as 123123.

Now what is the sum of digits in odd places from left? $1 + 3 + 2 = 6$

What is the sum of digits in even places from the right? $2 + 1 + 3 = 6$

what is the difference between these sums? Zero.

Hence 123123 is divisible by 11.

Take any 3 digits number and make a number by writing it two times. It is exactly divisible by 11.



Try These

1. Verify whether 789789 is divisible by 11 or not.
2. Verify whether 348348348348 is divisible by 11 or not?
3. Take an even palindrome i.e. 135531 check whether this number is divisible by 11 or not?
4. Verify whether 1234321 is divisible by 11 or not?



Exercise - 15.3

1. Check whether the given numbers are divisible by '6' or not ?
(a) 273432 (b) 100533 (c) 784076 (d) 24684
2. Check whether the given numbers are divisible by '4' or not ?
(a) 3024 (b) 1000 (c) 412 (d) 56240
3. Check whether the given numbers are divisible by '8' or not ?
(a) 4808 (b) 1324 (c) 1000 (d) 76728

4. Check whether the given numbers are divisible by '7' or not ?
 (a) 427 (b) 3514 (c) 861 (d) 4676
5. Check whether the given numbers are divisible by '11' or not using divisibility rules
 (a) 786764 (b) 536393 (c) 110011 (d) 1210121
 (e) 758043 (f) 8338472 (g) 54678 (h) 13431
 (i) 423423 (j) 168861
6. If a number is divisible by '8', then it also divisible by '4' also . Explain ?
7. A 3-digit number 4A3 is added to another 3-digit number 984 to give four digit number 13B7, which is divisible by 11, then find (A + B).

15.2 Some More Divisibility Rules

- (a) Let us observe a few more rules about the divisibility of numbers.

Consider a factor of 24 , say 12.

Factors of 12 are 1,2,3,4,6,12

Let us check whether 24 is divisible by 2,3,4,6 we can say that 24 is divisible by all factors of 12.

So, if a number 'a' is divisible by another number 'b', then it is divisible by each of the factors of that number 'b'.



- (b) Consider the number 80. It is divisible by 4 and 5. It is also divisible by $4 \times 5 = 20$, where 4 and 5 are co primes to each other. (have no common factors for 4 and 5)

Similarly, 60 is divisible by 3 and 5 which have no common factors each other 60 is also divisible by $3 \times 5 = 15$.

If 'a' and 'b' have no common factors (other than unity), the number divisible by 'a' and 'b' is also divisible by $a \times b$



(Check the property if 'a' and 'b' are not co-primes).

- (c) Take two numbers 16 and 20. These numbers are both divisible by 4. The number $16 + 20 = 36$ is also divisible by 4.

Try this for other common divisors of 16 and 20.

Check this for any other pairs of numbers.

If two given numbers are divisible by a number, then their sum is also divisible by that number.



- (d) Take two numbers 35 and 20. These numbers are both divisible by 5. Is their difference $35 - 20 = 15$ also divisible by 5? Try this for other pairs of numbers also.

If two given numbers are divisible by a number, then their difference is also divisible by that number.



Do These

1. Take different pairs of numbers and check the above four rules for given number
2. 144 is divisible by 12. Is it divisible by the factors of 12? verify.
3. Check whether $2^3 + 2^4 + 2^5$ is divisible by 2? Explain
4. Check whether $3^3 - 3^2$ is divisible by 3? Explain

Consider a number, product of three consecutive numbers i.e. $4 \times 5 \times 6 = 120$. This is divisible by 3. Because in these consecutive numbers one number is multiple of 3. Similarly if we take product of any three consecutive numbers among those one number is multiple of 3. Hence product of three consecutive is always divisible by 3.



Try This

1. Check whether $1576 \times 1577 \times 1578$ is divisible by 3 or not.

Divisibility Rule of 7 for larger numbers

We discussed the divisibility of 7 for 3-digit numbers. If the number of digits of a number are more than 3 we make it simple to find divisibility of 7.

Check a number 7538876849 is divisible by 7 or not.

Step 1 : Make the number into groups of 3-digits each from right to left. If the left most group is less than 3 digits take it as group.

$$\begin{array}{cccc} 7 & | & 538 & | & 876 & | & 849 & | \\ & & D & & C & & B & & A \end{array}$$

Step 2 : Add the groups in alternate places i.e. A + C and B + D.

$$\begin{array}{r} 849 \\ + 538 \\ \hline 1387 \end{array} \qquad \begin{array}{r} 876 \\ + 7 \\ \hline 883 \end{array}$$

Step 3 : Subtract 883 from 1387 and check the divisibility rule of 7 for the resultant 3 digit number as previously learnt

$$\begin{array}{r} 1387 \\ - 883 \\ \hline \end{array}$$

504 By divisibility rule of 7 we know that 504 is divisible by 7. Hence the given number is divisible by 7.



Try This

1. Check the above method applicable for the divisibility of 11 by taking 10-digit number.

By using the divisibility rules , we can guess the missing digit in the given number.

Suppose a number 84763A9 is divisible by 3, we can guess the value for sum of digits is $8 + 4 + 7 + 6 + 3 + A + 9 = 37 + A$. To be divisible by 3 , A has values either 2 or 5 or 8.



Exercise - 15.4

1. Check whether 25110 is divisible by 45.
2. Check whether 61479 is divisible by 81 .
3. Check whether 864 is divisible by 36? Verify whether 864 is divisible by all the factors of 36 ?
4. Check whether 756 is divisible by 42? Verify whether 756 is divisible by all the factors of 42?
5. Check whether 2156 is divisible by 11 and 7? Verify whether 2156 is divisible by product of 11 and 7 ?
6. Check whether 1435 is divisible by 5 and 7? Verify if 1435 is divisible by the product of 5 and 7?

7. Check whether 456 and 618 are divisible by 6? Also check whether 6 divides the sum of 456 and 618 ?
8. Check whether 876 and 345 are divisible by 3? Also check whether 3 divides the difference of 876 and 345 ?
9. Check whether $2^2+2^3+2^4$ is divisible by 2 or 4 or by both 2 and 4 ?
10. Check whether 32^2 is divisible by 4 or 8 or by both 4 and 8 ?
11. If A679B is a 5-digit number is divisible by 72 find 'A' and 'B'?

15.3 Puzzles based on divisibility rules

Raju and Sudha are playing with numbers . Their conversation is as follows :

Sudha said , let me ask you a question.

Sudha : Choose a 2- digit number

Raju : Ok . I choose. (He choose 75)

Sudha : Reverse the digits (to get a new number)

Raju : Ok .

Sudha : Add this to the number you choosen

Raju : Ok . (I did)

Sudha : Now divide your answer with 11, you will get the remainder zero.

Raju : Yes . but how do you know ? Can you think why this happens ?

Now let us understand the logic behind the Sudha's trick

Suppose Raju chooses the number $10a + b$ (such that "a" is a digit in tens place and "b" is a digit in units place and $a \neq 0$) can be written as $10 \times a + b = 10a + b$ and on reversing the digits he gets the number $10b + a$. When he adds the two numbers he gets $(10a + b) + (10b + a) = 11a + 11b = 11(a + b)$

The sum is always multiple of 11. Observe that if she divides the sum by 11 , the quotient is $(a + b)$, which is exactly the sum of digits a and b of chosen number.

You may check the puzzle by taking any other two digit number .





Do These

- Check the result for following the numbers instead of Raju was chosen.
(i) 37 (ii) 60 (iii) 18 (iv) 89
- In a cricket team there are 11 players. The selection board purchased $10x + y$ T-Shirts to players. They again purchased $10y + x$ T-Shirts and total T-Shirts were distributed to players equally. How many T-Shirts will be left over after they distributed equally to 11 players? How many each one will get?



Think, Discuss and Write

Take a two digit number reverse the digits and get another number. Subtract smaller number from bigger number. Is the difference of those two numbers is always divisible by 9?



Do This

- In a basket there are $10a + b$ fruits. ($a \neq 0$ and $a > b$). Among them $10b + a$ fruits are rotten. The remaining fruits distributed to 9 persons equally. How many fruits are left over after equal distribution? How many fruits would each child get?

15.4 Fun with 3-Digit Numbers

Sudha : Now think of a 3- digit number.

Raju : Ok . (he chooses 157)

Sudha : Reverse the digits and subtract smaller number from the larger number

Raju : Ok.

Sudha : Divide your answer with 9 or 11. I am sure there will be no remainder .

Raju : Yes. How would you know ?

Right ! How does Sudha know ?

We can derive the logic the way we did for the 3-digit number chosen by Raju is $100a + 10b + c$.

By reversing the digits she get $100c + 10b + a$.

If ($a > c$) difference between the numbers is $(100a + 10b + c) - (100c + 10b + a)$

$$= 99a - 99c = 99(a - c)$$

$$= 9 \times 11 \times (a - c)$$



If ($c > a$) difference between the numbers is $(100c + 10b + a) - (100a + 10b + c)$

$$= 99c - 99a = 99(c - a) = 9 \times 11 \times (c - a)$$

And if $a = c$, then the difference is '0'

In each case the result is a multiple of 99. Therefore, it is divisible by both 9 and 11, and the quotient is $(a - c)$ or $(c - a)$.



Do This

1. Check in the above activity with the following numbers ?

- (i) 657 (ii) 473 (iii) 167 (iv) 135



Try This

Take a three digit number and make the new numbers by replacing its digits as (ABC, BCA, CAB). Now add these three numbers. For what numbers the sum of these three numbers is divisible?

15.5 Puzzles with missing digits

We can also have some puzzles in which we have alphabet in place of digits in an arithmetic sum and the task is to find out which alphabet represents which digit. Let us do some problems of addition and multiplication.

The three conditions for the puzzles.

1. Each letter of the puzzle must stand for just one digit. Each digit must be represented by just one letter.
2. The digit with highest place value of the number can not be zero.
3. The puzzle must have only one answer.

Example 6: Find A in the addition $17A$

$$\begin{array}{r} 17A \\ + 2A4 \\ \hline 407 \\ \hline \end{array}$$

Solution : By observation $A + 4 = 7$.

Hence $A = 3$

$$173 + 234 = 407$$

or $100 + 70 + A$

$$\frac{200 + 10A + 4}{300 + 70 + 11A + 4} = 407$$

$$300 + 70 + 11A + 4 = 407$$

$$11A = 33$$

$$A = 3$$

Example 7 : Find M and Y in the addition $Y + Y + Y = MY$

Solution : $Y + Y + Y = MY$

$$3Y = 10M + Y$$

$$2Y = 10M$$

$$M = \frac{Y}{5} \quad (\text{i.e. } Y \text{ is divisible by } 5. \text{ Hence } Y = 0 \text{ or } 5)$$

From above, if $Y = 0$, $Y + Y + Y = 0 + 0 + 0 = 0$, $M = 0$

if $Y = 5$, $Y + Y + Y = 5 + 5 + 5 = 15$, $MY = 15$ Hence $M = 1$, $Y = 5$

Example 8 : In $A2 - 15 = 5A$, $A2$ and $5A$ are two digit numbers, then find A

Solution : $2 - 5 = a$ is possible

when $12 - 5 = 7$,

There fore $A = 7$

$$(10A + 2) - (10 + 5) = 50 + A$$

$$10A - 13 = 50 + A$$

$$9A = 63$$

$$A = 7$$

Example 9 : In $5A1 - 23A = 325$, $5A1$ and $23A$ are three digit numbers, then find A

Solution : $1 - A = 5$? or $(500 + 10A + 1) - (200 + 30 + A) = 325$

i.e. $11 - A = 5$,

There fore $A = 6$

$$501 - 230 + 10A - A = 325$$

$$271 + 9A = 325$$

$$271 + 9A = 325$$

$$271 - 271 + 9A = 325 - 271$$

$$9A = 54$$

$$A = 6$$

Example 10: In $1A \times A = 9A$, $1A$ and $9A$ are two digit numbers. Find A

Solution : For $A \times A = A$ or $(10 + A)A = (90 + A)$

From square tables 1, 5, 6 $10A + A^2 = 90 + A$

$$1 \times 1 = 1,$$

$$5 \times 5 = 25,$$

$$6 \times 6 = 36,$$

$$\text{if } A = 6,$$

$$16 \times 6 = 96$$

$$A^2 + 9A - 90 = 0$$

$$A^2 + 2.A\left(\frac{9}{2}\right) + \left(\frac{9}{2}\right)^2 - \left(\frac{9}{2}\right)^2 - 90 = 0$$

$$\left(A + \frac{9}{2}\right)^2 - \frac{81}{4} - 90 = 0$$

$$\left(A + \frac{9}{2}\right)^2 = \frac{441}{4}$$

$$A + \frac{9}{2} = \frac{21}{2}$$

$$A = \frac{12}{2} = 6$$

Example 11 : In $BA \times B3 = 57A$. BA , $B3$ are two digit numbers and $57A$ is a 3 digit number. Then find A and B .

Solution : In this example we estimate the value of digits from multiplication tables by trial and error method. In one's place $A \times 3 = A$. For $A = 0$ or 5 , the unit digit of product becomes same digit.

Hence A is either 0 or 5 . If we take 1 at tens place then, to the utmost value of two digit number is 19 . The product could be $19 \times 19 = 361$. Which is less than $57A$. Further if we take 3 at tens place then the atleast value of both two digit number will be $30 \times 30 = 900$ which is greater than $57A$. So, it will be 2 at tens place. Then $20 \times 23 = 460$ or $25 \times 23 = 575$.

Hence, the required answer is $25 \times 23 = 575$.



Do These

1. If $21358AB$ is divisible by 99 , find the values of A and B
2. Find the value of A and B of the number $4AB8$ (A, B are digits) which is divisible by $2, 3, 4, 6, 8$ and 9 .

Example 12: Find the value of the letters in the given multiplication

Solution : If we take $B = 0$ or 1 or 5 then $0 \times 5 = 0$, $1 \times 5 = 5$, $5 \times 5 = 25$

If $B = 0$, then $A0 \times 5 = CA0$

$$\begin{array}{r} AB \\ \times 5 \\ \hline CAB \end{array}$$

then if we take $A = 5$, then $50 \times 5 = 250$
 $\therefore CAB = 250$.



Try These

- If $YE \times ME = TTT$ find the numerical value of $Y + E + M + T$
 [Hint : $TTT = 100T + 10T + T = T(111) = T(37 \times 3)$]
- If cost of 88 articles is $A733B$. find the value of A and B



Exercise -15.5

- Find the missing digits in the following additions.

(a) $\begin{array}{r} 111 \\ + A \\ + 77 \\ \hline 197 \end{array}$	(b) $\begin{array}{r} 222 \\ + 8 \\ + BB \\ \hline 285 \end{array}$	(c) $\begin{array}{r} AAA \\ + 7 \\ + AA \\ \hline 373 \end{array}$	(d) $\begin{array}{r} 2222 \\ + 99 \\ + 9 \\ \hline AAA \\ \hline 299A \end{array}$	(e) $\begin{array}{r} BB \\ + 6 \\ \hline AAA \\ \hline 461 \end{array}$
---	---	---	---	--
- Find the value of A in the following

(a) $7A - 16 = A9$ (b) $107 - A9 = 1A$ (c) $A36 - 1A4 = 742$
- Find the numerical value of the letters given below-

(a) $\begin{array}{r} \boxed{D} \boxed{E} \\ \times 3 \\ \hline \boxed{F} \boxed{D} \boxed{E} \end{array}$	(b) $\begin{array}{r} \boxed{G} \boxed{H} \\ \times 6 \\ \hline \boxed{C} \boxed{G} \boxed{H} \end{array}$
--	--
- Replace the letters with appropriate digits

(a) $73K \div 8 = 9L$ (b) $1MN \div 3 = MN$
- If $ABB \times 999 = ABC123$ (where A, B, C are digits) find the values of A, B, C .

15.6 Finding of divisibility by taking remainders of place values

In this method we take remainders by dividing the place values, with given number.

If we divide the place values of a number by 7, we get the remainders as

- $1000 \div 7$ (Remainder 6. This can be taken as $6 - 7 = -1$)
 $100 \div 7$ (Remainder 2)
 $10 \div 7$ (Remainder 3)
 $1 \div 7$ (Remainder 1)

Place value	10^8	10^7	10^6	10^5	10^4	10^3	10^2	10^1	10^0
Remainders divide by 7	3	2	1	-2	-3	-1	2	3	1

Suppose to check whether 562499 is divisible by 7 or not.

Digits	5	6	2	4	9	9
Place values	5×10^5	6×10^4	2×10^3	4×10^2	9×10^1	9×10^0
Remainders divided by 7	$5 \times (-2)$	$6 \times (-3)$	$2 \times (-1)$	4×2	9×3	9×1

Sum of product of face values and remainders of place values is

$$-10 - 18 - 2 + 8 + 27 + 9 = -30 + 44 = 14 \text{ (divisible by 7)}$$

14 is divisible by 7, hence 562499 is divisible by 7.



Do These

- By using the above method check whether 7810364 is divisible by 4 or not.
- By using the above method check whether 963451 is divisible by 6 or not.

15.7 Some more puzzles on divisibility rules

Example 13: Is every even number of palindrome is divisible by '11'?

Solution: Let us take an even number of palindrome i.e. 12344321. The sum of digits in odd places is $1 + 3 + 4 + 2$. Sum of digits in even places $2 + 4 + 3 + 1$. Their difference is 0. Hence, it is divisible by 11.

Example 14: Is $10^{1000} - 1$ divisible by both 9 and 11?

Solution: Let us write $10^{1000} - 1$ as 999 ... 999 (1000 times). The digits in all places are 9. Hence, it is divisible by 9. And there are 1000 digits. Sum of digits in odd places and sum digits even places are same. Their difference is 0. Hence, it is divisible by 11.



Think, Discuss and Write

- Can we conclude $10^{2n} - 1$ is divisible by both 9 and 11? Explain.
- Is $10^{2n+1} - 1$ is divisible by 11 or not. Explain.

Example 15: Take any two digit number three times to make a 6-digit number. Is it divisible by 3 ?

Solution: Let us take a 2-digit number 47. Write three times to make 6-digit number i.e. 474747.

474747 can be written as $47(10101)$. 10101 is divisible by 3. Because sum of its digit is $1 + 1 + 1 = 3$. Hence 474747 is divisible by 3.

Example 16: Take any three digit number and write it two times to make a 6-digit number. Verify whether it is divisible by both 7 and 11.

Solution: Let us take a 3-digit number 345. Write it two times to get 6-digit number i.e. 345345.

$$\begin{aligned} 345345 \text{ can be written as } 345345 &= 345000 + 345 = 345(1000 + 1) \\ &= 345(1001) \\ &= 345(7 \times 11 \times 13) \end{aligned}$$

Hence 345345 is divisible by 7, 11 and 13 also.



Try This

1. Check whether 456456456456 is divisible by 7, 11 and 13?

Example 17: Take a three digit number in which all digits are same. Divide the number with reduced number. What do you notice?

Solution: Consider 444 as a 3-digit number. Reduced number of 444 is $4 + 4 + 4 = 12$. Now divide 444 by 12, $444 \div 12 = 37$. Do the process with 333, 666, etc. You will be supposed the quotient is 37 for all the numbers.

Example 18: Is $2^3 + 3^3$ is divisible by $(2 + 3)$ or not?

Solution: We know that $a^3 + b^3 = (a + b)(a^2 - ab + b^2)$.

So $2^3 + 3^3 = (2 + 3)(2^2 - 2 \times 3 + 3^2)$. It is multiple of $(2 + 3)$.

Hence $2^3 + 3^3$ is divisible by $(2 + 3)$.



Think, Discuss and Write

1. Verify $a^5 + b^5$ is divisible by $(a + b)$ by taking different natural numbers for 'a' and 'b'?
2. Can we conclude $(a^{2n+1} + b^{2n+1})$ is divisible by $(a + b)$?

15.8 Finding Sum of Consecutive numbers

We can find the sum of consecutive numbers from 1 to 100 without adding.

$$\begin{aligned} & 1 + 2 + 3 + \dots + 50 + 51 + \dots + 98 + 99 + 100 \\ &= (1 + 100) + (2 + 99) + (3 + 98) + \dots + (50 + 51) \\ &= 101 + 101 + 101 + \dots + 101 \quad \text{50 pairs are there.} = 50 \times 101 = 5050 \end{aligned}$$

$$\text{Sum of the first 100 natural numbers} = \frac{100 \times 101}{2} = 5050.$$

$$\text{The sum of the first 'n' natural numbers} = \frac{n(n+1)}{2}$$

Example 19: Find the sum of integers which are divisible by 5 from 50 to 85.

Solution: Sum of integers which are divisible by 5 from 50 to 85 = (Sum of integers which are divisible by 5 from 1 to 85) – (Sum of integers which are divisible by 5 from 1 to 49)

$$\begin{aligned} &= (5 + 10 + \dots + 85) - (5 + 10 + \dots + 45) \\ &= 5(1 + 2 + \dots + 17) - 5(1 + 2 + \dots + 9) \\ &= \\ &= 5 \times 9 \times 17 - 5 \times 9 \times 5 \\ &= 5 \times 9 \times (17 - 5) \\ &= 5 \times 9 \times 12 = 540 \end{aligned}$$

Example 20: Find the sum of integers from 1 to 100 which are divisible by 2 or 3.

Solution: The numbers which are divisible by 2 from 1 to 100 are 2, 4, ... 98, 100.

The numbers which are divisible by 3 from 1 to 100 are 3, 6, ... 96, 99.

In the above series some numbers are repeated twice. Those are multiple of 6 i.e. LCM of 2 and 3.

Sum of integers which are divisible by 2 or 3 from 1 to 100 = (Sum of integers which are divisible by 2 from 1 to 100) + (Sum of integers which are divisible by 3 from 1 to 100) – (Sum of integers which are divisible by 6 from 1 to 100)

$$\begin{aligned} &= (2 + 4 + \dots + 100) + (3 + 6 + \dots + 99) - (6 + 12 + \dots + 96) \\ &= 2(1 + 2 + \dots + 50) + 3(1 + 2 + \dots + 33) - 6(1 + 2 + \dots + 16) \\ &= 2 \times \left(\frac{50 \times (50+1)}{2} \right) + 3 \times \left(\frac{33 \times (33+1)}{2} \right) - 6 \times \left(\frac{16 \times (16+1)}{2} \right) \end{aligned}$$

$$\begin{aligned}
&= \cancel{2} \times \left(\frac{50 \times 51}{\cancel{2}} \right) + 3 \times \left(\frac{33 \times \cancel{34}^{17}}{\cancel{2}} \right) - 6 \times \left(\frac{8 \times \cancel{16} \times 17}{\cancel{2}} \right) \\
&= 2550 + 1683 - 816 \\
&= 4233 - 816 = 3417
\end{aligned}$$



Exercise – 15.6

- Find the sum of integers which are divisible by 5 from 1 to 100.
- Find the sum of integers which are divisible by 2 from 11 to 50.
- Find the sum of integers which are divisible by 2 and 3 from 1 to 50.
- $(n^3 - n)$ is divisible by 3. Explain the reason.
- Sum of 'n' odd number of consecutive numbers is divisible by 'n'. Explain the reason.
- Is $1^{11} + 2^{11} + 3^{11} + 4^{11}$ divisible by 5? Explain.
- | | | | | | | |
|--|--|--|--|--|--|--|
| | | | | | | |
|--|--|--|--|--|--|--|

Find the number of rectangles of the given figure ?
- Rahul's father wants to deposit some amount of money every year on the day of Rahul's birthday. On his 1st birth day ₹ 100, on his 2nd birth day ₹ 300, on his 3rd birth day ₹ 600, on his 4th birthday ₹ 1000 and so on. What is the amount deposited by his father on Rahul's 15th birthday.
- Find the sum of integers from 1 to 100 which are divisible by 2 or 5.
- Find the sum of integers from 11 to 1000 which are divisible by 3.



What we have discussed

- Writing and understanding a 3-digit number in expanded form $100a + 10b + c$. Where a, b, c digits $a \neq 0$, b, c is from 0 to 9
- Deducing the divisibility test rules of 2, 3, 4, 5, 6, 7, 8, 9, 10, 11 for two or three digit number expressed in the general form.
- Logic behind the divisibility laws of 2, 3, 4, 5, 6, 7, 8, 9, 10, 11.
- Number puzzles and games.



Answers



1. Rational Numbers

Exercise - 1.1

1.
 - (i) Additive Identity
 - (ii) Distributive law
 - (iii) Multiplicative identity
 - (iv) Multiplicative identity
 - (v) Commutative law of addition
 - (vi) Closure law in multiplication
 - (vii) Additive inverse law
 - (viii) Multiplicative inverse
 - (ix) Distributive
2. (i) $\frac{3}{5}, \frac{-5}{3}$ (ii) $-1, 1$ (iii) Does not exist (iv) $\frac{-7}{9}, \frac{9}{7}$
(v) $1, -1$
3. (i) $\frac{-12}{5}$ (ii) 0 (iii) $\frac{9}{11}$ (iv) $\frac{6}{7}$
(v) $\frac{3}{4}, \frac{1}{3}$ (vi) 0 4. $\frac{-28}{55}$
5. Multiplicative Associative, multiplicative inverse, multiplicative identity, closure with addition.
6. Associative law.
7. $\frac{28}{15}$ 8. (i) $\frac{-5}{12}$ (ii) $\frac{58}{13}$ (iii) $\frac{45}{7}$
9. $\frac{-7}{8}$ 10. $\frac{53}{6}$
11. Not associative Since $\left(\frac{1}{2} - \frac{1}{3}\right) - \frac{1}{4} \neq \frac{1}{2} - \left(\frac{1}{3} - \frac{1}{4}\right)$
13. (i) Natural numbers (ii) 0 (iii) Negative

Exercise - 1.3

1. (i) $\frac{57}{100}$ (ii) $\frac{22}{125}$ (iii) $\frac{100001}{100000}$ (iv) $\frac{201}{8}$
2. (i) 1 (ii) $\frac{19}{33}$ (iii) $\frac{361}{495}$ (vi) $\frac{553}{45}$
3. (i) $\frac{7}{13}$ (ii) $\frac{-7}{5}$
4. $\frac{-62}{65}$ 5. 140 6. $5\frac{1}{10}$ m 7. ₹. 1.66
8. $161\frac{1}{5}$ m² 9. $\frac{3}{4}$ 10. $\frac{16}{9}$ m 11. 15



2. Linear Equations in one variable

Exercise - 2.1

- 1.(i) 2 (ii) -3 (iii) -6 (iv) 6
(v) $\frac{-3}{2}$ (vi) -21 (vii) 27 (viii) 5
(ix) $\frac{7}{3}$ (x) 1 (xi) $\frac{1}{2}$ (xii) 0
(xiii) $\frac{25}{7}$ (xiv) $\frac{21}{16}$ (xv) $\frac{8}{3}$ (xvi) $\frac{13}{6}$

Exercise - 2.2

- 1.(i) 67^0 (ii) 17^0 (iii) 125^0 (iv) 19^0
(v) 20^0
2. 5, 13 3. 43, 15 4. 27, 29
5. 252, 259, 266 6. 20 km 7. 99g, 106g, 95g 8. 113m, 87m
9. 16m, 12m 10. 21m, 21m, 13m
11. 51^0 and 39^0 12. 20 years, 28 years 13. 126
14. 80, 10 15. 60, 48 16. 59 ft, 29.5 ft
17. 186, 187.

Exercise - 2.3

- | | | | |
|-------------------|--------------------|-------------------|-------------------|
| 1. 1 | 2. 2 | 3. $\frac{11}{4}$ | 4. -1 |
| 5. $\frac{-9}{5}$ | 6. 1 | 7. 7 | 8. $\frac{-4}{7}$ |
| 9. $\frac{9}{2}$ | 10. $\frac{11}{3}$ | 11. 1 | 12. -96 |
| 13. 3 | 14. 8 | | |

Exercise - 2.4

- | | | | |
|-------|---------|-------|---------------|
| 1. 25 | 2. 7 | 3. 63 | 4. 40, 25, 15 |
| 5. 12 | 6. 4, 2 | 7. 16 | 8. 10,000 |

Exercise - 2.5

- | | | | |
|------------------------|-----------|--|-----------------------|
| 1.(i) $\frac{145}{21}$ | (ii) 168 | (iii) 12 | (iv) 25 |
| (v) $\frac{127}{12}$ | (vi) 1 | (vii) $\frac{9}{2}$ | (viii) $\frac{5}{12}$ |
| (ix) $\frac{9}{23}$ | (x) -1 | (xi) $\frac{-1}{7}$ | (xii) $\frac{3}{7}$ |
| 2. 30 | 3. 48, 12 | 4. $\frac{3}{7}$ | 5. 50, 51, 52 |
| 6. 25 | 7. 5 | 8. One Rupee coins = 14; 50 paise coins = 42 | |
| 9. 30 days | 10. 20 km | 11. 36 | |
| 12. ₹ 860 | 13. 16 | | |

**4. Exponents and Powers****Exercise - 4.1**

- | | | | |
|---------------------------------------|--------------------|-----------------------|--------------------------|
| 1.(i) $\frac{1}{64}$ | (ii) -128 | (iii) $\frac{64}{27}$ | (iv) $\frac{1}{81}$ |
| 2.(i) $\left(\frac{1}{2}\right)^{15}$ | (ii) $(-2)^{14}$ | (iii) 5^4 | (iv) 5^5 (v) $(-21)^4$ |
| 3.(i) $2^4 \times 3$ | (ii) $\frac{1}{2}$ | | |

- 4.(i) 10 (ii) 40^3 (iii) $\frac{13}{16}$ (iv) $\frac{2}{81}$
- (v) $\frac{17}{6}$ (vi) $\frac{16}{81}$ 5. (i) 625 (ii) 625
- 6.(i) 10 (ii) -10 (iii) 2 7. 3
8. $\frac{4^5}{3^4 \times 5}$ 9. (i) 1 (ii) 72 (iii) -24 (iv) 1
10. $\frac{16}{49}$

Exercise - 4.2

- 1.(i) 9.47×10^{-10} (ii) 5.43×10^{11} (iii) 4.83×10^7 (iv) 9.298×10^{-5}
 (v) 5.29×10^{-5}
- 2.(i) 4,37,000 (ii) 5,80,00,000 (iii) 0.00325 (iv) 37152900
 (v) 0.03789 (vi) 0.02436
- 3.(i) 4×10^{-7} m (ii) 7×10^{-6} mm (iii) 3×10^8 m/sec (iv) 3.84467×10^8
 (v) 1.6×10^{-19} coulombs (vi) 1.6×10^{-3} cm (vii) 5×10^{-6} cm
4. 1.0008×10^2 mm
- 5.(i) No (ii) No (iii) No (iv) No (v) No



5. Comparing Quantities using Proportion

Exercise - 5.1

- 1.(i) 3:4 (ii) 32:3 (iii) 1:2 2. 168
3. 8 4. 48 5. 20 6. $\frac{4}{3}, \frac{3}{4}, \frac{4}{5}, \frac{5}{4}, \frac{3}{5}, \frac{5}{3}$
7. 3 : 5 8. 4 : 7 9. ₹ 8320
10. $\frac{1}{2}, \frac{1}{2}, \frac{1}{2}$, yes 11. ₹ 28.5, ₹ 92, ₹ 257.6, ₹ 132, ₹ 88
12. (a) 83 (b) 1992 members 13. 2064 bags 14. 70 cm

Excercise - 5.2

1. 81.9 crores
2. ₹ 2756.25
3. ₹ 7.674
4. $3 \text{ cm} \times 6 \text{ cm}$
5. ₹ 127.50
6. $6\frac{1}{4}\%$
7. 17%
8. ₹ 880, 10%, ₹ 4,000, 20%, ₹ 10,000, 20%, profit, ₹ 392, ₹ 42, ₹ 315, ₹ 35.
9. ₹ 2244
10. ₹ 1250
11. 40,000; 12.5%
12. Profit ₹ 30,000, profit % 17.64 %
13. ₹ 1334
14. (i) ₹ 10,000 (ii) ₹ 3,000 (iii) ₹ 200
15. (i) ₹ 540, ₹ 5040 (ii) ₹ 5040
16. 13

Excercise - 5.3

1. (a) ₹ 268.75
2. ₹ 19,950
3. $A = ₹ 8820$, $C.I = ₹ 820$
4. ₹ 734.50, ₹ 7234.50
5. ₹ 86950 ; ₹ 1449.1
6. 81,82,199
7. ₹ 1080.56
8. (i) ₹ 210
9. ₹ 43.20
10. 5,31,616
11. ₹ 36659.70
12. Bharathi ; ₹ 362.50
13. ₹ 9500
14. 1297920
15. ₹ 103.81



6. Square Roots, Cube Roots

Excercise - 6.1

1. (i) Unit digit in the square of 39 is 1
(ii) Unit digit in the square of 297 is 9
(iii) Unit digit in the square of 5125 is 5
(iv) Unit digit in the square of 7286 is 6
(v) Unit digit in the square of 8742 is 4
2. Perfect squares are
(i) 121 (ii) 256
3. (i) 257 unit digit is 7 and hence not a perfect square
(ii) 4592 unit digit is 2 and hence not a perfect square
(iii) 2433 unit digit is 3 and hence not a perfect square
(iv) 5050 unit digit is 0 and number of zeros at the end is only one and hence not a perfect square
(v) 6098 unit digit is 8 and hence not a perfect square
4. (i) 431^2 - odd (ii) 2826^2 - even (iii) 8204^2 - even
(iv) 17779^2 - odd (v) 99998^2 - even

5. (i) 50 (ii) 112 (iii) 214
 6. (i) 25 (ii) 81 (iii) 169

Excercise - 6.2

1. (i) 21 (ii) 28 (iii) 64 (iv) 84
 2. 5 3. 6, 120 4. 6 5. 39
 6. 51 7. 144, 9 8. 89 9. 4608 m²

Excercise - 6.3

1. (i) 33 (ii) 48 (iii) 88 (iv) 78
 (v) 95
 2. (i) 1.6 (ii) 4.3 (iii) 8.3 (iv) 9.2
 3. 31 4. 67 cm 5. 91 6. 1024
 7. 149 8. (i) 10 (ii) 16 (iii) 28

Excercise - 6.4

1. (i) 512 (ii) 4096 (iii) 9261 (iv) 27000
 2. i) 243 - Not a perfect cube ii) 516 - Not a perfect cube
 iii) 729 - a perfect cube vi) 8000 - a perfect cube
 v) 2700 - Not a perfect cube
 3. 2 4. 17 5. 5 6. 288 7. 2

Excercise - 6.5

1. (i) 7 (ii) 9 (iii) 11 (iv) 14
 1. (i) 8 (ii) 13 (iii) 15 (iv) 18
 3. i) False ii) False iii) True iv) True
 v) False vi) False vii) False 4. 64



7. Frequency Distribution Tables and Graphs

Exercise 7.1

1. ₹.11060.83 2. $\bar{x} = 7$ 3. $\bar{x} = 27$ 4. $\bar{x} = 43$
 5. $\bar{x} = 30$ years 6. 52 years
 7. $\bar{x} = 12$ sum of deviations from $\bar{x} = 0$

8. 5 9. $\bar{x} = 13.67$ same in all cases. 10. 15.3 marks
 11. $\bar{x} = 30$ 12. Median = 3.4 13. $x = 18$
 14. Mode = 10 15. Mode = $x - 3$ 16. Does not exist
 17. 12, 16, 16, 16 18. 42 19. 8 20. 20

Exercise - 7.2

1. Class Interval	5-14	15-24	25-34	35-44	45-54	55-64
Frequency	9	9	9	6	7	5

2. No of Students	15-19	19-23	23-27	27-31	31-35	35-39	39-43
Frequency	5	7	6	5	5	1	1

3. Class intervals	4-11	12-19	20-27	28-35	36-43	44-51	52-59
Boundaries	3.5-11.5	11.5-19.5	19.5-27.5	27.5-35.5	35.5-43.5	43.5-51.5	51.5-59.5

4. Class Marks	Frequency cu.f	Class Intervals cu.f	Less than	Greater than
10	6	4-16	6	75
22	14	16-28	20	69
34	20	28-40	40	55
46	21	40-52	61	35
58	9	52-64	70	14
70	5	64-76	75	5

5. CI (Marks)	0-10	10-20	20-30	30-40	40-50
Fr(Students)	2	10	4	9	10

6. Class Interval (Ages)	Frequency (No.of children)	Class Boundries	LEss than Cu.frequency	Greater than Cu.frequency
1 - 3	10	0.5 - 3.5	10	59
4 - 6	12	3.5 - 6.5	22	49
7 - 9	15	6.5 - 9.5	37	37
10 - 12	13	9.5 - 12.5	50	22
13 - 15	9	12.5 - 15.5	59	9

7. CI	0-10	10-20	20-30	30-40	40-50
Cu fr	3	8	19	25	30
Frequency	3	5	11	6	5

Given frequencies are less than cumulative frequencies.

8. CI	1-10	11-20	21-30	31-40	41-50
G.Cu fr	42	36	23	14	6
Frequency	6	13	9	8	6



8. Exploring Geometrical Figures

Exercise - 8.1

2. (a) Yes; any two congruent figures are always similar.
(b) Yes; the similarity remains.
3. $AB = NM$; $\angle A = \angle N$
 $BC = MO$; $\angle B = \angle M$
 $CA = ON$; $\angle C = \angle O$
4. (i) True (ii) False (iii) True (iv) False
(v) True
7. 1.5 m, 3m, 4.5m, 6m, 7.5m, 9m
8. 9m



9. Area of Plane Figures

Exercise 9.1

2. (i) 20 sqcm (ii) 424 sqcm (iii) 384 sqcm
3. 55 sqcm. 4. 96 sqcm 5. (i) 10700 sqm (ii) 10650 sqm
6. (ii) $x = 75$ cm, 45 cm
7. ₹ 4050
8. 337.5 sqcm.

Exercise - 9.2

- 361 sq cm
- 616 sqcm.
- (i) 693 sqcm. (ii) 259.87 cm²
- 1386 cm²
- 308 cm²
- 10.5 cm²
- 7.8729 cm²
- (i) $\frac{6}{7}a^2$ (ii) 123.42 cm²
- 6.125 cm²
- 346.5 m²



10. Direct and Inverse Proportion

Exercise 10.1

- ₹ 84, ₹ 168, ₹ 420, ₹ 546
- 32, 56, 96, 160
- ₹ 12,600/-
- ₹ 2,100/-
- 21 cm
- 6m, 8.75 m
- 168 km
- 5000
- 25 km, $\frac{10}{3}$ hr.
- $\frac{9}{20}$ cm.
- 2 : 1

Exercise - 10.2

- (ii)
- 120, 60, 80, 80

Exercise - 10.3

- 4 kg
- 2.50 days
- 48
- 50 minutes
- 4
- 15
- 24
- 60 min
- 40%
- $\frac{(x+1)^2}{(x+2)}$

Exercise - 10.4

- ₹540
- 2 days
- 16 days
- 4.325 men
- 36 days



11. Algebraic Expressions

Exercise - 11.1

- (i) 42K (ii) 6lm (iii) 15t⁴ (iv) 18mn
(v) 10p³
- (ii) 60a²c (iii) 24m³n (iv) 36 k³l³ (v) 24p²q²r²
- i) x⁵y³ ii) a⁶b⁶ iii) k³l³m³ iv) p²q²r²
v) 72a²bcd
- x²y²z²
- x³y

Exercise - 11.2

- (ii) $3k^2l + 3k/m + 3kmn$ (iii) $a^2b^2 + ab^4 + ab^2c^3$
(iv) $x^2yz - 2xy^2z + 3xyz^2$ (v) $a^4b^3c^3 + a^2b^4c^3d - a^3b^3c^2d^2$
- $12y^2 + 16y$
- i) -2 ii) 0
- $a^2 + b^2 + c^2 - ab - bc - ca$ 5. $x^2 - y^2 - z^2 + 2xy - yz + zx - xr + yr$
- $-7x^2 + 8xy$ 7. $-3k^2 + 21kl - 21km$
- $a^3 + b^3 + c^3 - a^2b + b^2a - b^2c + c^2b + a^2c - c^2a$

Exercise - 11.3

- (i) $6a^2 - 19a - 36$ (ii) $2x^2 - 5xy + 2y^2$ (iii) $k^2l - kl^2 - l^2m + k/m$
(iv) $m^3 + m^2n - mn^2 - n^3$
- (i) $2x^2 - 3xy + 3x^2y + 3xy^2 - 5y^2$
(ii) $3a^2b^2 - a^3b - 2ab^3 - 3a^2bc + 3ab^2c$
(iii) $klmn - lm^2n - k^2l^2 + kl^2m + k^2/m - k/m^2$
(iv) $p^4 - 5p^3q + 6p^3r + pq^3 + 6q^3r - 5q^4$
- i) $10x^2 - 14xy$ ii) $m^3 + n^3$ iii) $-19a^2 - 3b^2 + 3c^2 - 34ab + 16ac$
iv) $p^2q^2 - q^2r^2 + p^2qr + pqr^2 - p^2q - pq^2 - p^2r + pr^2$ 4. 8

Exercise - 11.4

- i) $9k^2 + 24kl + 16l^2$ ii) $a^2x^4 + 2abx^2y^2 + b^2y^4$
iii) $49d^2 - 126de + 81e^2$ iv) $m^4 - n^4$
v) $9t^2 - 81s^2$ vi) $k^2l^2 - m^2n^2$
vii) $36x^2 + 66x + 30$ viii) $4b^2 - 2ab + 2bc - ca$
- i) 92416 ii) 259081 iii) $9,84,064$ iv) $6,38,401$
v) $89,984$ vi) 6391 vii) $11,772$ viii) $42,024$



12. Factorisation

Exercise - 12.1

- (i) $1, 2, 4, 8$ (ii) $1, 3, a, 3a$ (iii) $1, 7, x, y, 7x, 7y, xy, 7xy$ (iv) $1, 2, m, m^2, 2m, 2m^2$
(v) $1, 5$ (vi) $1, 2, x, 2x$ (vii) $1, 2, 3, 6, x, y, 2x, 3x, 2y, 3y, 6x, 6y, xy, 2xy, 3xy, 6xy$

2. i) $5x(x - 5y)$ (ii) $3a(3a - 2x)$ (iii) $7p(p + 7q)$
 iv) $12a^2b(3 - 5c)$ (v) $3abc(a + 2b + 3c)$
 vi) $p(4p + 5q - 6q^2)$ (vii) $t(u + at)$

3. (i) $(3x - 4b)(a - 2y)$
 (ii) $(x^2 + 5)(x + 2)$ (iii) $(m + 4)(m - n)$
 (iv) $(a^2 - b)(a - b^2)$ (v) $(p - 1)(pq - r^2)$

Exercise - 12.2

1. (i) $(a + 5)^2$ (ii) $(l - 8)^2$ (iii) $(6x + 8y)^2$ (iv) $(5x - 3y)^2$
 (v) $(5m - 4n)^2$ (vi) $(9x - 11y)^2$ (vii) $(x - y)^2$ (viii) $(l^2 + 2m^2)^2$
2. (i) $(x + 6)(x - 6)$ (ii) $(7x + 5y)(7x - 5y)$ (iii) $(m + 11)(m - 11)$
 (iv) $(9 + 8x)(9 - 8x)$ (v) $(xy + 8)(xy - 8)$ (vi) $6(x + 3)(x - 3)$
 (vii) $(x + 9)(x - 9)$ (viii) $2x(1 + 4x^2)(1 + 2x)(1 - 2x)$
 (ix) $x^2(9x + 11)(9x - 11)$ (x) $(p - q + r)(p - q - r)$
 (xi) $4xy$
3. (i) $x(lx + m)$ (ii) $7(y^2 + 5z^2)$ (iii) $3x^2(x^2 + 2xy + 3z)$
 (vi) $(x - a)(x - b)$ (v) $(3a + 4b)(x - 2y)$ (vi) $(m + 1)(n + 1)$
 (vii) $(b + 2c)(6a - b)$ (viii) $(pq - r^2)(p - 1)$ (ix) $(y + z)(x - 5)$
4. (i) $(x^2 + y^2)(x + y)(x - y)$ (ii) $(a^2 + b^2 + c^2 + 2bc)(a + b + c)(a - b - c)$
 (iii) $(l + m - n)(l - m + n)$ (iv) $\left(7x + \frac{4}{5}\right)\left(7x - \frac{4}{5}\right)$
 (v) $(x^2 - y^2)^2$ (vi) $(5a - b)(5b - a)$
5. (i) $(a + 6)(a + 4)$ (ii) $(x + 6)(x + 3)$ (iii) $(p - 7)(p - 3)$
 (iv) $(x - 8)(x + 4)$

Exercise - 12.3

1. (i) $8a^2$ (ii) $\frac{1}{3}x$ (iii) $9a^2b^2c^2$ (iv) $\frac{1}{5}yz^2$
 (v) $-6l^2m$
2. (i) $3x - 2$ (ii) $5a^2 - 7b^2$ (iii) $x(5x - 3)$ (iv) $l(2l^2 - 3l + 4)$

(v) $5abc(a - b + c)$ (vi) $(2q^2 + 3pq - p^2)$

(vii) $\frac{4}{3}(abc + 2bc)$

3. (i) $7x - 9$

(ii) $12x$

(iii) $\frac{77}{3}ab$

(iv) $\frac{27}{4}(m+n)$

(v) $4(x^2 + 7x + 10)$ (vi) $(a + 1)(a + 2)$

4. (i) $x + 4$

(ii) $x - 2$

(iii) $p + 4$

(iv) $5a(a - 5)$

(v) $10m(p - q)$ (vi) $4z(4z + 3)$

Exercise - 12.4

(i) $3(x - 9) = 3x - 27$

(ii) $x(3x + 2) = 3x^2 + 2x$

(iii) $2x + 3x = 5x$

(iv) $2x + x + 3x = 6x$

(v) $4p + 3p + 2p + p - 9p = p$

(vi) $3x \times 2y = 6xy$

(vii) $(3x)^2 + 4x + 7 = 9x^2 + 4x + 7$

(viii) $(2x)^2 + 5x = 4x^2 + 5x$

(ix) $(2a + 3)^2 = 4a^2 + 12a + 9$

(x) (a) $9 - 21 + 12 = 0$

(b) $9 + 15 + 6 = 30$

(c) $9 - 15 = -6$

(xi) $(x - 4)^2 = x^2 - 8x + 16$

(xii) $(x + 7)^2 = x^2 + 14x + 49$

(xiii) $(3a + 4b)(a - b) = 3a^2 + ab - 4b^2$

(xiv) $(x + 4)(x + 2) = x^2 + 6x + 8$

(xv) $(x - 4)(x - 2) = x^2 - 6x + 8$

(xvi) $5x^3 \div 5x^3 = 1$

(xvii) $(2x^3 + 1) \div 2x^3 = 1 + \frac{1}{2x^3}$

(xviii) $(3x + 2) \div 3x = 1 + \frac{2}{3x}$

(xix) $(3x + 5) \div 3 = x + \frac{5}{3}$

(xx) $\frac{4x+3}{3} = \frac{4}{3}x + 1$



13. Visualising 3 - D in 2 - D

Exercise - 13.1

3. (i) 5

(ii) 9

(iii) 20

(iv) 14

4. (i) 3 sq.units

(ii) 9 sq.units

(iii) 16 sq.units

(iv) 14 sq.units

Exercise -13.2

	F	V	E	V + F = E + 2
1.	5	6	9	Satisfied
	7	10	15	„
	8	12	18	„
	6	6	10	„
	5	5	8	„
	8	12	18	„
	8	6	12	„
	6	8	12	„

2. All cubes are square prisms, but converse is not true 3. Does not exist 4. Yes

5. $F = 20, V = 6, E = 12, V + F - E = 2$ 6. No

7.

V	E
8	12
5	8
6	9

8. (i) Hexagonal pyramid (ii) Cuboid (iii) Pentagonal pyramid
 (iv) Cylinder (v) Cube (vi) Hexagonal pyramid
 (vii) Trapezoid

9. (i) a, b, c, d, e (ii) (a) Tetrahedron (b) sphere
 (c) Cube/cuboid (d) sphere
 (e) Cube is a regular polyhedron where cuboid is not.
 (f) Cube, Cuboid (g) Square Pyramid

3. (a) Octagonal Prism (b) hexagonal prism
 (c) triangular prism (d) Pentagonal pyramid



14. Surface Areas and Volumes

Exercise - 14.1

1. A 2. 10 cm 3. $9m^2$
 4. ₹.72

Exercise - 14.2

- (i) 112.996 m^3 (ii) 70m^3 (iii) 22.5m^3
- (i) 13.92m^3 , 13920 liters. (ii) 5.2 m^3 , 5200 liters
(iii) 36.792 m^3 , 36792 liters.
- Volume decreases by $\frac{7}{8}$ times.
- (i) 262.144 cm^3 (ii) 2.197m^3 (iii) 4.096m^3
- 6400 6. 1096 cm^3 7. 110cm^3
- 90 9. 27 10. 6 cm.



15. Playing with Numbers

Exercise - 15.1

- Divisible by 2 1200, 836, 780, 4820, 48630
Divisible by 5 1200, 535, 780, 3005, 4820, 48630
Divisible by 10 1200, 780, 4820, 48630

We observed that, if a number is divisible 10, is also divisible by 2 and 5 also.

- (a), (b), (c), (e) are divisible by 2
- (a), (b), (c) (d) are divisible by 5
- (a), (b), (d), (e) are divisible by 10
- (a) 6 (b) 8
(c) 6 (d) 12 (e) 8
- 10, 20, 30, 40, 50, 60,
- 6

Exercise - 15.2

- A = 2 or 5 or 8 2. A = 8
- 90, 180, 270, 360, 450 etc.
- 0 to 9. We observed that divisibility of 2 does not depends upon other than unit's digit.
- 0 or 5 6. 4 7. 7 8. '0'

Exercise - 15.3

1. (a), (d) are divisible by 6
2. (a), (b), (c), (d) are divisible by 4
3. (a), (c), (d) are divisible by 8
4. (a), (b), (c), (d) are divisible by 7
5. (a), (b), (c), (d), (e), (h), (i), (j) are divisible by 11
6. All multiples of 8 are multiples of 4
7. $A = 1$, $B = 9$, $A + B = 10$

Exercise - 15.4

1. divisible by 45
2. divisible by 81
3. divisible by 36 and by all its factors
4. divisible by 42 and by all its factors
5. divisible by 11 and 7 and also divisible product of 11 and 7
6. divisible by 5 and 7 and also divisible by product of 5 and 7.
7. Both numbers and their sum also divisible by 6
8. Both the numbers and their difference also divisible by 3
9. Divisible by both 2 and 4
10. Divisible by both 4 and 8
11. $A = 3$, $B = 2$

Exercise - 15.5

1. (a) $A = 9$ (b) $B = 5$ (c) $A = 3$ (d) $A = 6$, sum = 2996
(e) $A = 4$, $B = 1$
2. (a) $A = 5$ (b) $A = 8$ (c) $A = 9$
3. (a) $D = 5$, $E = 0$, $F = 1$
4. (a) $K = 6$, $L = 2$ (b) $M = 5$, $N = 0$
5. $A = 8$, $B = 7$, $C = 6$

Exercise - 15.6

1. 1050
2. 620
3. 216
4. $n^3 - n = n(n^2 - 1) = (n - 1)n(n + 1)$ product of three consecutive numbers.
5. Sum of n consecutive odd number is $\frac{(2n-1)(2n)}{2} = n(2n-1)$ multiple of ' n '.
6. $(1^{11} + 4^{11}) + (2^{11} - 3^{11})$ is divisible by 5.
7. $1 + 2 + 3 + 4 + 5 + 6 = 21$
8. ₹ 12000
9. 3050
10. $166833 - 18 = 166815$.

SCERT, TELANGANA

SYLLABUS

Number System (50 hrs)

(i) Rational Numbers

(ii) Square numbers, cube numbers, Square roots, Cubes, Cube roots.

(iii) Playing with numbers

(i) Rational Numbers

- Properties of rational numbers. (including identities).
- Using general form of expression to describe properties. Appreciation of properties.
- Representation of rational numbers on the number line
- Between any two rational numbers there lies another rational number (Making children see that if we take two rational numbers then unlike for whole numbers, in this case you can keep finding more and more numbers that lie between them.)
- Representation of rational numbers as decimal and vice versa (denominators other than 10, 100, ...)
- Consolidation of operations on rational numbers.
- Word problems on rational numbers (all operations)

(ii) Square numbers, cube numbers, Square roots, Cubes, Cube roots.

- Square numbers and square roots.
- Square roots using factor method and division method for numbers containing. no more than 4 digits and b) no more than 2 decimal places.
- Pythagorean triplets and verification of Pythagoras theorem
- Cube numbers and cube roots (only factor method for numbers containing at most 3 digits).
- Estimating square roots and cube roots. Learning the process of moving nearer to the required number.
- Uses of brackets
- Simplification of brackets using BODMAS rule.

(iii) Playing with numbers

- Writing and understanding a 2 and 3 digit number in generalized form $(100a + 10b + c)$ where a, b, c can be only digits (0-9) and engaging with various puzzles concerning this. (Like finding the missing numerals represented by alphabets in problems involving any of the four operations)

	<ul style="list-style-type: none"> • Number puzzles and games • Understanding the logic behind the divisibility tests of 2,3,4,5,6,7,8,9, and 11 for a two or three digit number expressed in the general form.
<p>Algebra (20 hrs)</p> <p>(i) Linear Equations in one variable</p> <p>(ii) Exponents & Powers</p> <p>(iii) Algebraic Expressions</p> <p>(iv) Factorisation</p>	<p>(i) Linear Equations in one variable</p> <ul style="list-style-type: none"> • Solving linear equations in one variable in contextual problems involving multiplication and division • Word problems
	<p>(ii) Exponents and Powers</p> <ul style="list-style-type: none"> • Standard form of the numbers • Integers as exponents. • Laws of exponents with integral powers
	<p>(iii) Algebraic Expressions</p> <ul style="list-style-type: none"> • Multiplication algebraic exp. (Coefficient should be integers) • Some common errors (e.g. $2 + x \neq 2x$, $7x + y \neq 7xy$) • Identities $(a \pm b)^2 = a^2 \pm 2ab + b^2$, $a^2 - b^2 = (a - b)(a + b)$ • Geometric verification of identities
	<p>(iv) Factorisation</p> <ul style="list-style-type: none"> • Factorisation by taking out common factor. • Factorisation by grouping the terms. • Factorisation by using identities. • Factors of the form $(x + a)(x + a)$ • Division of algebraic expressions

<p>Arithmetic (20 hrs)</p> <p>(i) Comparing Quantities using proportion</p> <p>(ii) Direct and Inverse proportion</p>	<p>(i) Comparing Quantities using proportion</p> <ul style="list-style-type: none"> Compound ratio - Word problems. Problems involving applications on percentages, profit & loss, overhead expenses, Discount, tax. (Multiple transactions) Difference between simple and compound interest (compounded yearly up to 3 years or half-yearly up to 3 steps only), Arriving at the formula for compound interest through patterns and using it for simple problems.
	<p>(ii) Direct and Inverse proportion</p> <ul style="list-style-type: none"> Direct variation - Simple and direct word problems. Inverse variation - Simple and direct word problems. Mixed problems on direct, inverse variation Time & work problems- Simple and direct word problems Time & distance: Simple and direct word problems
<p>Geometry (40 hrs)</p> <p>(i) Construction of Quadrilaterals</p> <p>(ii) Representing 3-D in 2D</p> <p>(iii) Exploring Geometrical Figures</p>	<p>(i) Construction of Quadrilaterals</p> <ul style="list-style-type: none"> Review of quadrilaterals and their properties. Construction of quadrilaterals, given with <ul style="list-style-type: none"> (i) Four sides and one angle (ii) Four sides and one diagonal (iii) Two adjacent sides, three angles (iv) Three sides and two diagonals. (v) Three sides and two angles in between them are given Construction of special types of quadrilaterals with two diagonals.
	<p>(ii) Exploring Geometrical Figures</p> <ul style="list-style-type: none"> Congruent figures Similar figures Symmetry in geometrical figures w.r.t. to triangles, quadrilaterals and circles.
	<p>(ii) Representing 3-D in 2D</p> <ul style="list-style-type: none"> Identify and Match pictures with objects [more complicated e.g. nested, joint 2-D and 3-D shapes (not more than 2)]. Drawing 2-D representation of 3-D objects (Continued and extended) with isometric sketches.

	<ul style="list-style-type: none"> Counting vertices, edges & faces & verifying Euler's relation for 3-D figures with flat faces (cubes, cuboids, tetrahedrons, prisms and pyramids)
<p>Mensuration (15 hrs)</p> <p>(i) Area of Plane Figures</p> <p>(ii) Surface areas and Volumes</p>	<p>(i) Area of Plane Figures</p> <ul style="list-style-type: none"> Area of a triangle using Heron's formula (without proof) and its application in finding the area of a quadrilateral. Area of a trapezium Area of the quadrilateral and other polygons. Area of the circle & circular paths. <p>(ii) Surface areas and Volumes</p> <ul style="list-style-type: none"> Surface area of a cube, cuboid Concept of volume, measurement of volume using a basic unit, volume of a cube, cuboid Volume and capacity.
<p>Data handling (15 hrs)</p> <p>Frequency Distribution Tables and Graphs</p>	<p>Frequency Distribution Tables and Graphs</p> <ul style="list-style-type: none"> Revision of Mean, Median and Mode of ungrouped data. Determination of mean by deviation method. Scope and necessity of grouped data. Preparation of frequency distribution tables Cumulative frequency distribution tables Frequency graphs (histogram, frequency polygon, frequency curve, cumulative frequency curves)

Academic Standards

Academic standards are clear statements about what students must know and be able to do.

The following are categories on the basis of which we lay down academic standards

Problem Solving

Using concepts and procedures to solve mathematical problems

(a) Kinds of problems

Problems can take various forms- puzzles, word problems, pictorial problems, procedural problems, reading data, tables, graphs etc.

(b) Problem Solving

- Reads problems
- Identifies all pieces of information/data
- Separates relevant pieces of information
- Understanding what concept is involved
- Recalling of (synthesis of) concerned procedures, formulae etc.
- Selection of procedure
- Solving the problem
- Verification of answers of raiders, problem based theorems.

(c) Complexity

The complexity of a problem is dependent on

- Making connections(as defined in the connections section)
- Number of steps
- Number of operations
- Context unraveling
- Nature of procedures

Reasoning Proof

- Reasoning between various steps (involved invariably conjuncture).
- Understanding and making mathematical generalizations and conjectures

- Understands and justifies procedures
- Examining logical arguments.
- Understanding the notion of proof
- Uses inductive and deductive logic
- Testing mathematical conjectures

Communication

- Writing and reading, expressing mathematical notations (verbal and symbolic forms)
Ex: $3 + 4 = 7$, $3 < 5$, $n_1 + n_2 = n_2 + n_1$, Sum of angles in a triangle = 180^0
- Creating mathematical expressions
- Explaining mathematical ideas in her own words like- a square is closed figure having four equal sides and all equal angles
- Explaining mathematical procedures like adding two digit numbers involves first adding the digits in the units place and then adding the digits at the tens place/ keeping in mind carry over.
- Explaining mathematical logic

Connections

- Connecting concepts within a mathematical domain- for example relating adding to multiplication, parts of a whole to a ratio, to division. Patterns and symmetry, measurements and space
- Making connections with daily life
- Connecting mathematics to different subjects
- Connecting concepts of different mathematical domains like data handling and arithmetic or arithmetic and space
- Connecting concepts to multiple procedures

Visualization & Representation

- Interprets and reads data in a table, number line, pictograph, bar graph, 2-D figures, 3-D figures, pictures
- Making tables, number line, pictograph, bar graph, pictures.
- Mathematical symbols and figures.

Textbook - Overview

The Government of Telangana has decided to revise the curriculum of all the subjects based on the State Curriculum Framework (SCF-2011) which recommends that life of children in schools must be linked to their life outside the school. Right to Education (RTE-2009) makes mandatory that every child entering school should acquire the necessary abilities prescribed at each level up to the age of 14 years. Therefore introduction of a syllabus based on National Curriculum Framework-2005 and SCF-2011 was necessary. The position paper on mathematics teaching brought out by the NCERT in 2006 and the position paper on the same subject by SCERT Telangana (and AP) 2011, pointed out that fear of mathematics makes many children drop out of school. It is because of this that it becomes important to make the school and classroom experience especially in mathematics more pertinent and comprehensible. The syllabus and material must be aligned to the national and state perspective on mathematics education and prepare our students with a strong base in mathematics and science without burdening them with too much information and/or memorization.

The strength of a nation lies in its commitment and capacity to prepare its people to meet the needs and aspirations of a progressive technological society. The syllabus in mathematics for three stages i.e. primary, upper primary and secondary is based on structured and spiral approaches. The teachers of secondary school mathematics have to look at the syllabus of classes 8 to 10 with this background. They must widen and deepen the understanding and application of concepts learnt by pupils in primary and upper primary stages. The syllabus of upper primary classes is based on the structural approach, laying emphasis on the discovery and understanding of basic mathematical concepts and generalizations. The text book has been written on the basis of curriculum. It has emerged after a thorough review of the previous books and books of equivalent states. The approach in curriculum, the syllabus, textbooks and hence in classroom processes is to encourage the pupils to participate, discuss and take an active part in the classroom processes.

Being the final stage of the elementary education, mathematics of class 8 is a bridge to mathematics of class 9 which deals with abstraction and more complex mathematical ideas and moving into beginning of formal mathematics.

The textbook attempts to give ample opportunities and space for children to engage in tasks and attempt problems based on the concepts included in the syllabus. For instance tasks like 'Do this' and 'Try this' have been included in between that involves thinking, reflecting and doing. The teacher and the students are supposed to pause and do these before moving forward and only give support, if needed.

The chapters are arranged in a spiral manner that children revisit each set of concepts of different areas at different times in the course of the year.

The syllabus has been divided broadly into six areas namely, (1) Number System (2) Algebra (3) Arithmetic (4) Geometry (5) Mensuration and (6) Data Handling.

Description of the chapters:

There are three chapters related to numbers and their properties. The chapter on rational numbers engages with problems dealing with multiplication and division operations on rational numbers. It also generalizes the properties of numbers to include rational numbers. There are four chapters focusing on operations and properties of algebraic expressions and equations to build a base for operations on linear equations with one or more variable. Children will learn to use graphs to analyze the nature of changes in quantities in linear relationships as well as solve contextualized problems represented in the form of tables and equations. In this way children would be able to identify quantitative relationships among variables and constants using mathematical models.

There are two chapters that relate to ratio and proportion and their application. In these the students engage with problems involving comparison of quantities using proportion like percentage, profit and loss, discount, tax, simple and compound interest. These chapters although distinct in the quantities that they use, are conceptually interrelated. They build on each other and hence can be used in a spiral manner to build an understanding of comparing quantities. Children learn about geometrical figures and patterns at an early stage. Now they have to learn to give a logical explanation for relationships in the frame of an argument. To understand the relationship between geometrical figures children have been introduced to the construction of geometrical figures with the help of some operations and their properties. In mensuration, two chapters deal with the areas of plane figures and the surface areas and volumes of 2-Dimensional and 3-Dimensional objects. Areas of some shapes have been calculated as sum of areas of basic shapes like rectangles and triangles. The syllabus discusses about different forms of representation of mathematical data in various ways such as graphs and frequency tables to signify the importance of organization and comprehension of data.

Therefore it is expected that the teachers will bring a paradigm shift in the classroom processes from routinely solving the problems in the exercises to build basic conceptual understanding and solving problems with ingenuity.

- Textbook Development Committee

LEARNING OUTCOMES

MATHEMATICS

CLASS 8

The learner....

- Generalizes properties of addition, subtraction, multiplication and division of rational numbers through patterns.
- Finds desired number of rational numbers in between any two given rational numbers.
- Proves divisibility of 2,3,4,5,6,9 and 11 by using algebraic methods and solves puzzles/ daily life problems.
- Solves problems using exponential laws in daily life.
- Finds squares, cubes, square roots and cube roots using different methods.
- Applies concept of percent in profit-loss, discount, VAT, simple interest, compound interest. And also solves problems involving ratios, direct and indirect variation.
- Solves daily life problems using algebraic expressions and identities. Also solves problems involving linear equations in one variable.
- Identifies similar figures. Calculates the ratio of corresponding parts.
- Constructs the quadrilaterals with given measurements.
- Finds the areas of trapezium, rhombus by using formulae. and finds areas of polygons and scalene quadrilaterals by dividing the region into triangles.
- Finds areas of figures/ designs involving area of circle and area of sector.
- Calculates the surface areas and volumes of cubes and cuboids.
- Finds mean, median and mode a data given in a tabular form.
- Represents the data in bar graphs, frequency curves and pi charts.



పాఠశాల ఏర్పాటు, శాఖ,
తెలంగాణ ప్రభుత్వం



Text Book Development Committee

Writers

Sri. Tata Venkata Rama Kumar

H.M., ZPPHS, Mulumudi, Nellore Dt.

Sri. Soma Prasad Babu

PGT. APTWRS, Chandrashekarapuram, Nellore

Sri. Komanduri Murali Srinivas

PGT. APTWR School of Excellence, Srisailam.

Sri. Padala Suresh Kumar

SA, GHS, Vijayanagar Colony, Hyderabad.

Sri. P.D.L. Ganapati Sharma

SA, GHS, Zamisthanpur, Manikeshwar Nagar, Hyd.

Sri. Duggaraju Venu

SA, UPS, Allawada, Chevella Mandal, R.R. Dt.

Sri. P. Anthony Reddy

H.M., St. Peter's High School, R.N.Peta, Nellore.

Sri D. Manohar

SA, ZPHS, Brahmanpally, Tadwai (Mandal) Nizamabad Dt.

Sri. Gottumukkala V.B.S.N. Raju

SA, Mpl. High School, Kaspa, Vizianagaram.

Sri. K. Varada Sunder Reddy

SA, ZPHS, Thakkasila, Alampur Mandal Mahabubnagar Dt.

Sri. Abbaraju Kishore

SGT, MPUPS, Chamallamudi, Guntur Dt.

Sri. G. Anantha Reddy

Retd. Headmaster, Ranga Reddy Dt.

Sri. M. Ramanjaneyulu

Lecturer, Govt D.I.E.T., Vikarabad, R.R. Dt.

Sri. M. Rama Chary

Lecturer, Govt D.I.E.T., Vikarabad, R.R. Dt.

Dr. A. Rambabu

Lecturer, Government CTE, Warangal

Dr. Poondla Ramesh

Lecturer, Government IASE, Nellore

Editors

Prof. N.Ch.Pattabhi Ramacharyulu (Retd.)

National Institute of Technology,
Warangal.

Dr. S Suresh Babu

Professor, Dept. of Statistics,
SCERT, Hyderabad

Prof. V. Shiva Ramaprasad (Retd.)

Dept. of Mathematics,
Osmania University, Hyderabad

Dr. G.S.N. Murthy

(Retd.)
Reader in Mathematics
Rajah R.S.R.K.R.R College, Bobbili

Sri A. Padmanabham

(Retd.)
H.O.D of Mathematics
Maharani College, Peddapuram

Sri. K Brahmaiah

(Retd.)
Prof., SCERT,
Hyderabad

Co-ordinators

Sri Kakulavaram Rajender Reddy

SCERT, Hyderabad

Sri K.K.V Rayalu

Lecturer, IASE, Masab Tank, Hyderabad

Academic Support Group Members

Sri Inder Mohan**Sri Yashwanth Kumar Dave****Sri Hanif Paliwal****Sri Asish Chordia**

Vidyabhawan Society Resource Centre, Udaipur

Sri Sharan Gopal**Kum M. Archana****Sri P. Chiranjeevi**

Department of mathematics and Statistics, University of Hyderabad

Illustrations and Design Team

Sri Prasanth Soni**Sri Sk. Shakeer Ahmad****Sri S. M. Ikram****Sri D. Kannaiah**

Vidyabhawan Society Resource Centre, Udaipur.

SCERT, TS, Hyd.

Cover Page Designing

Sri. K. Sudhakara Chary, HM, UPS Neelukurthy, Mdl. Maripeda, Dist. Warangal

TEXTBOOK DEVELOPMENT & PUBLISHING COMMITTEE

- Chief Production Officer :** **Sri A. Satyanarayana Reddy,**
Director, SCERT, Hyderabad.
- Executive Chief Organiser :** **Sri B. Sudhakar,**
Director, Govt. Text Book Press, Hyderabad.
- Organising Incharge :** **Dr. Nannuru Upender Reddy,**
Prof. & Head, Curriculum & Text Book Department,
SCERT, Hyderabad.

Chairperson for Position Paper and Mathematics Curriculum and Textbook Development

Prof. V.Kannan,
Department of Mathematics and Statistics,
Hyderabad Central University, Hyderabad

CHIEF ADVISORS

Sri Chukka Ramaiah
Eminent Scholar in Mathematics
Telangana, Hyderabad.

Dr. H.K.Dewan
Educational Advisor, Vidya Bhavan Society
Udaipur, Rajasthan

QR CODE TEAM

